

# WOOD TRICK

## ENGINEERING J00000000004

VINTAGE  
MACHINERY  
SERIES



MECHANICAL MODELS & KITS

### LOCOMOTIVE R-17



LEVEL 5

**405**  
PIECES

WDTK022

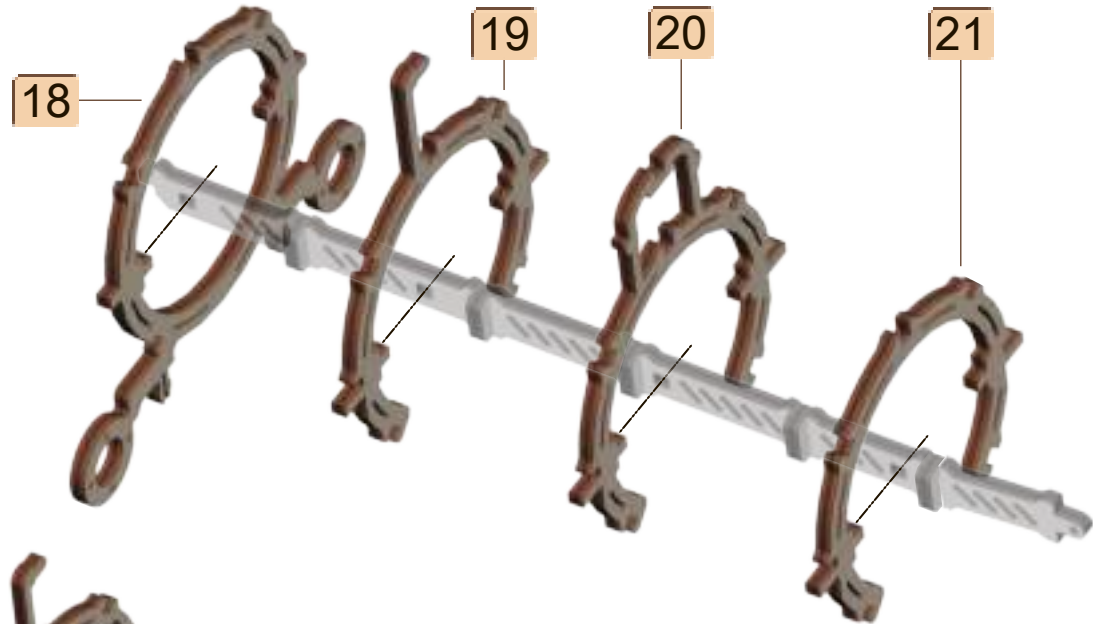
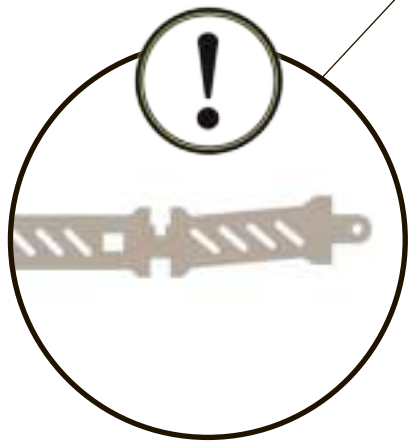
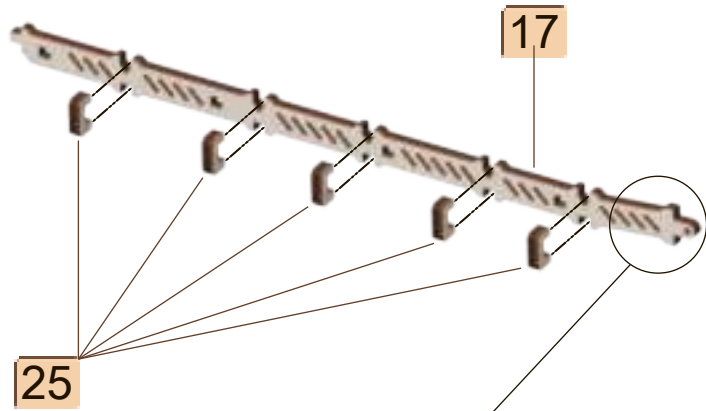
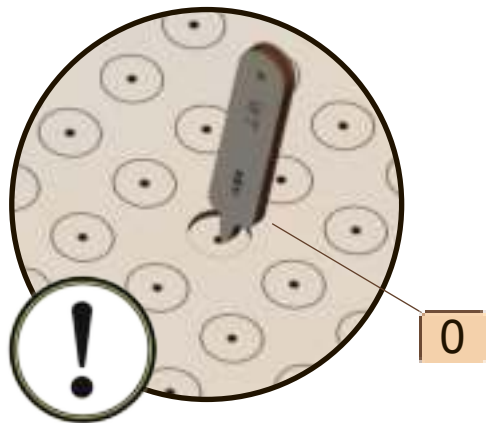

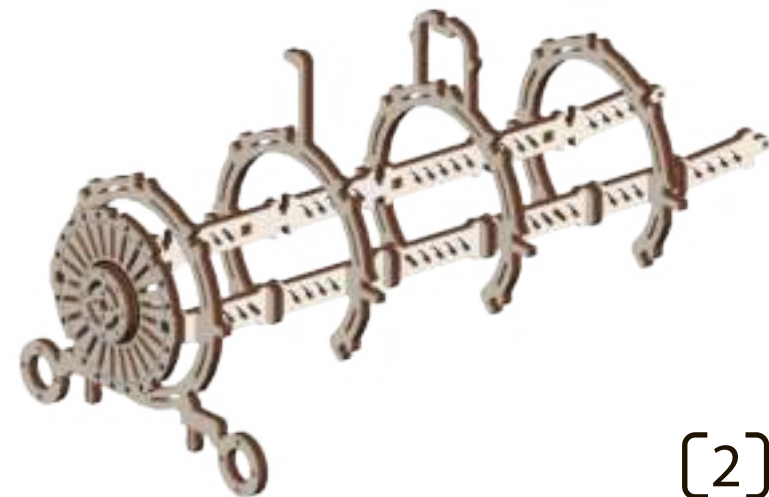
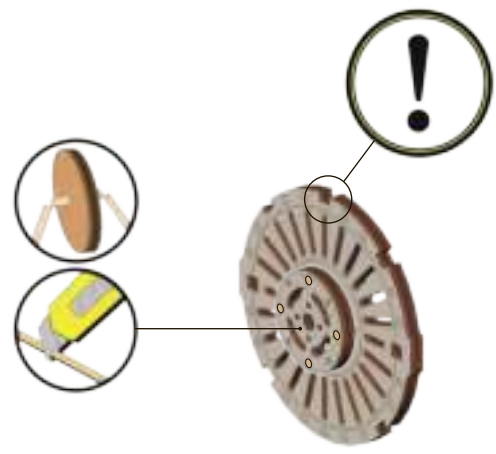
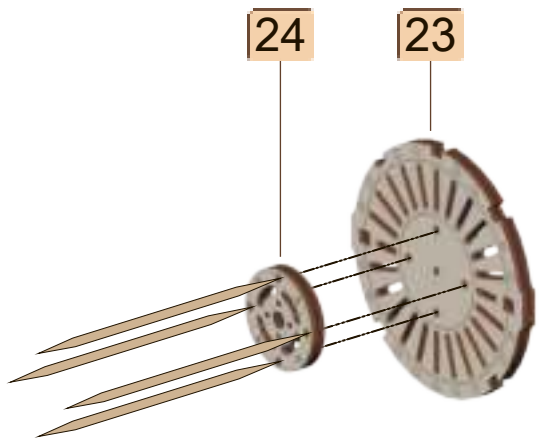
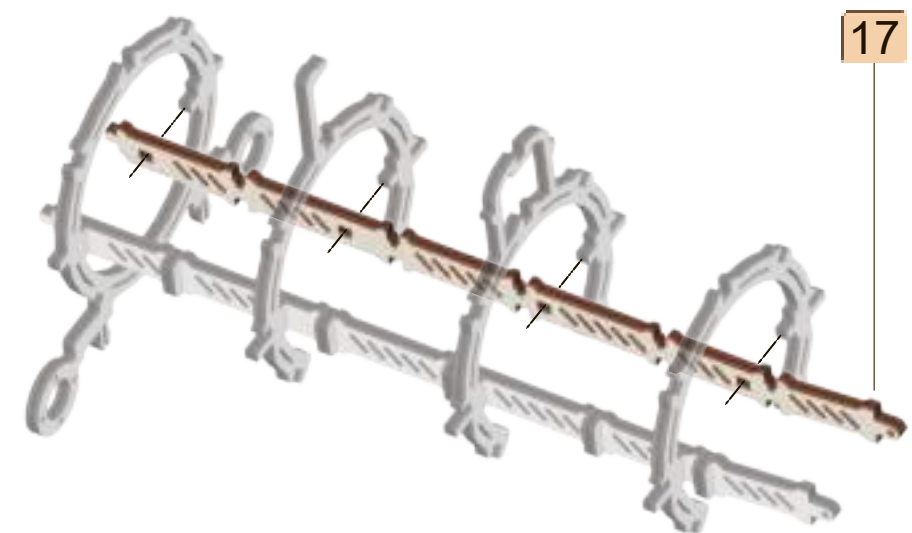
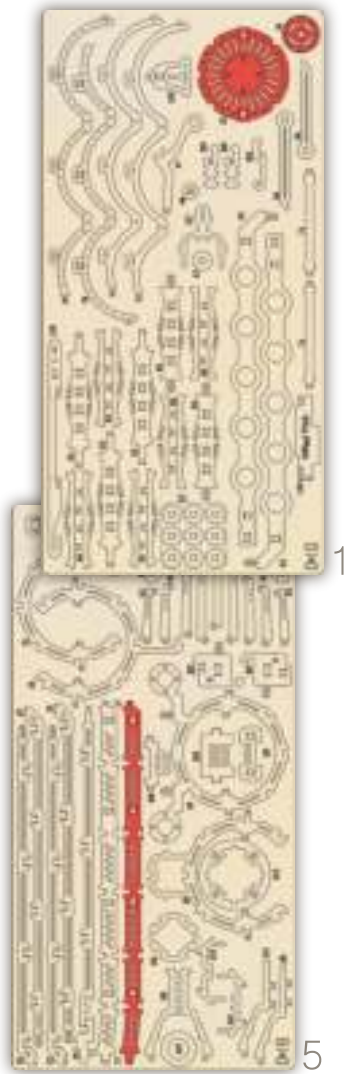

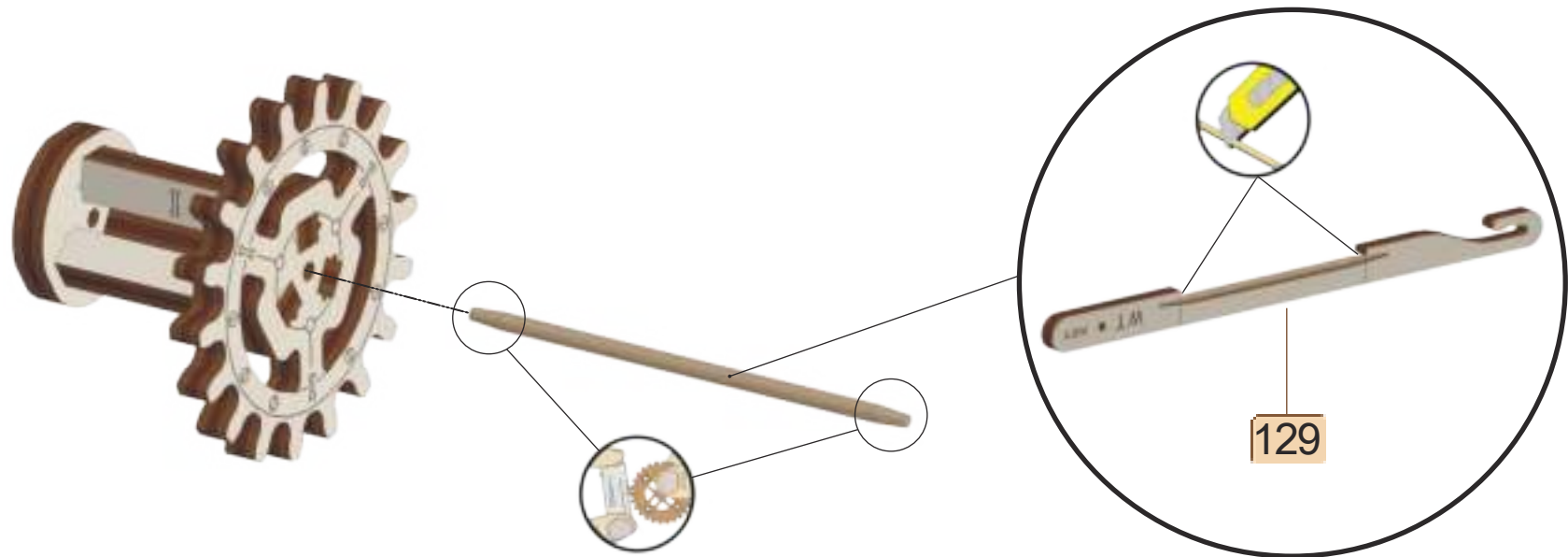
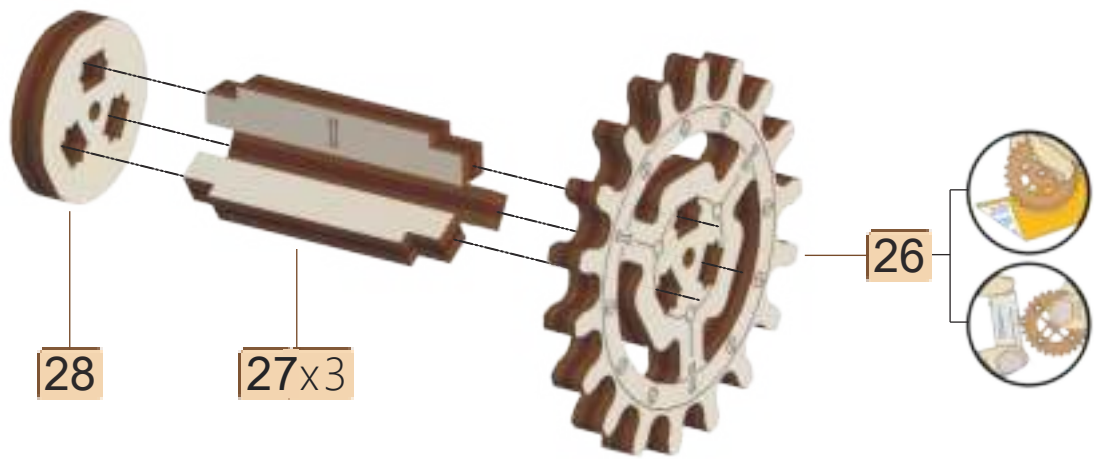



5

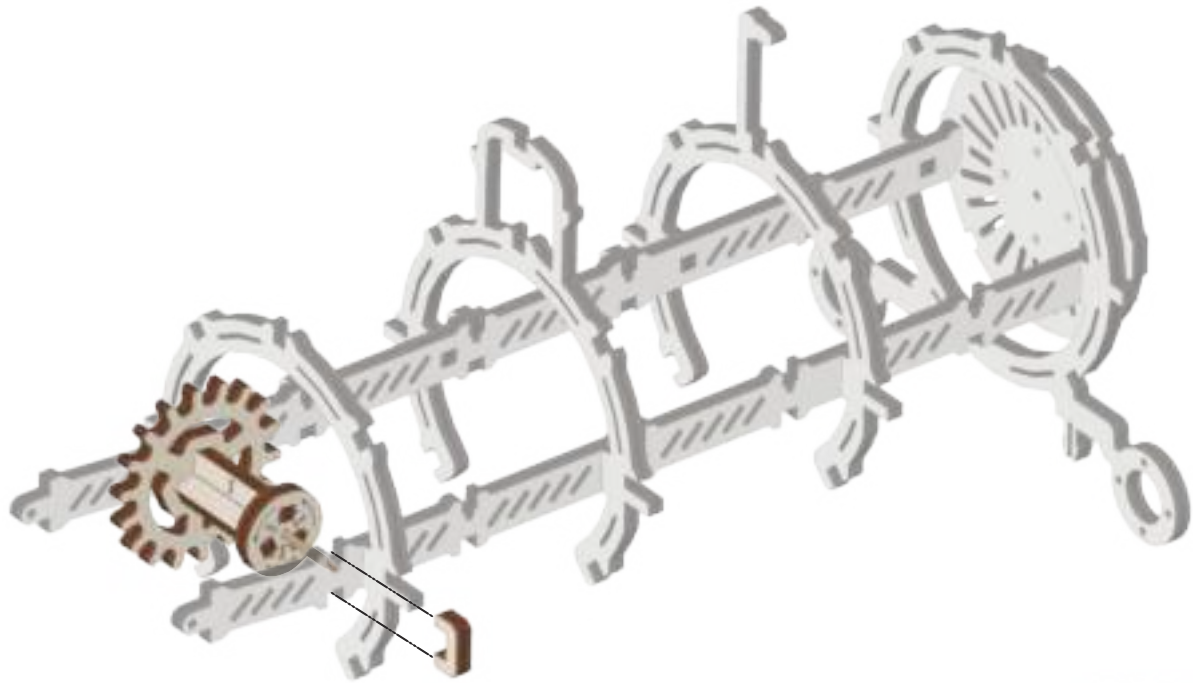

25

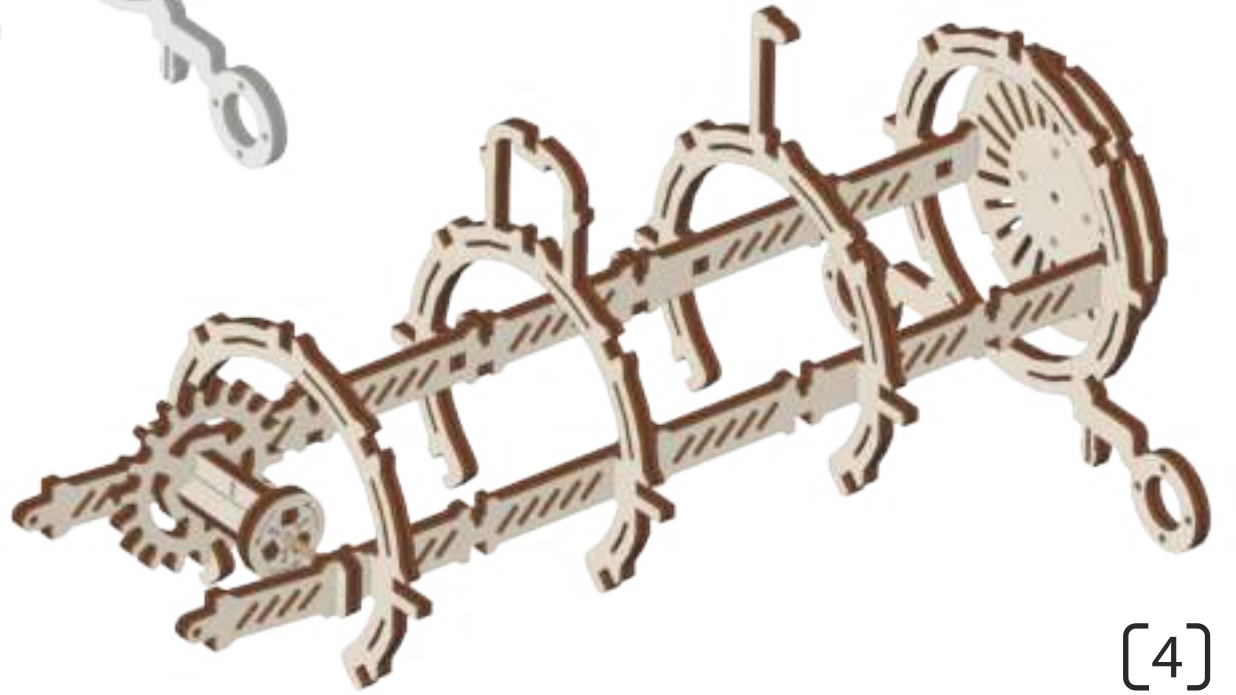

[4]

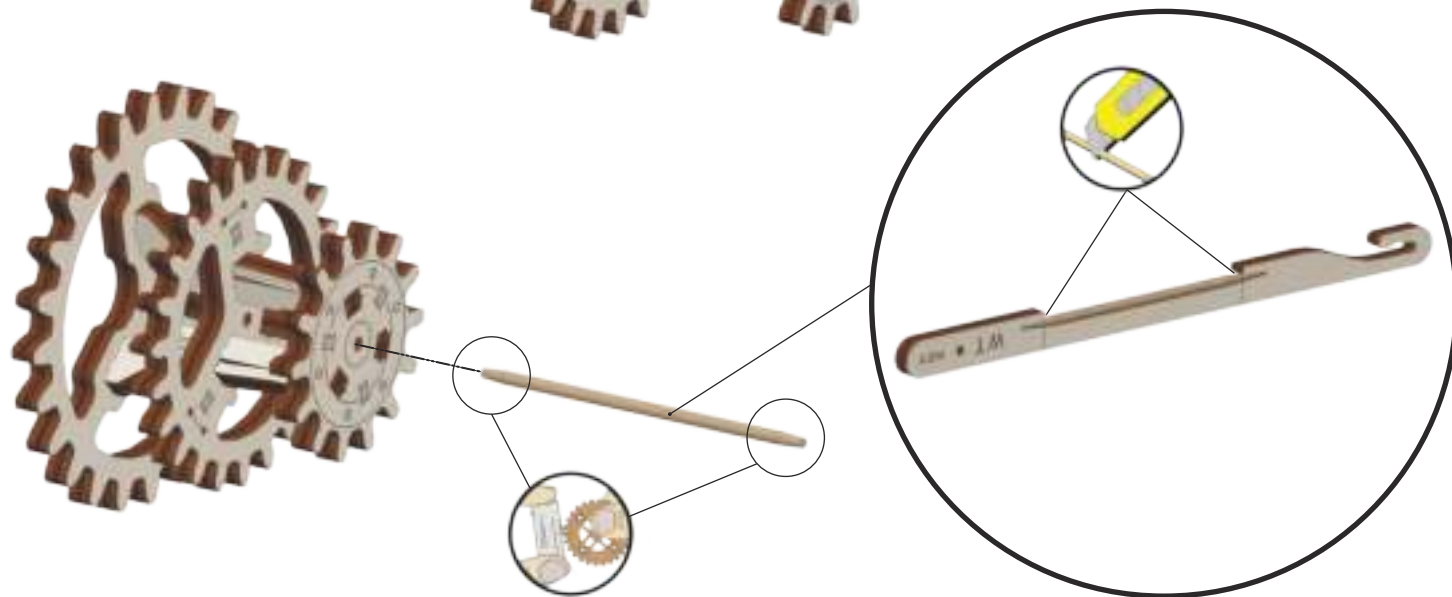
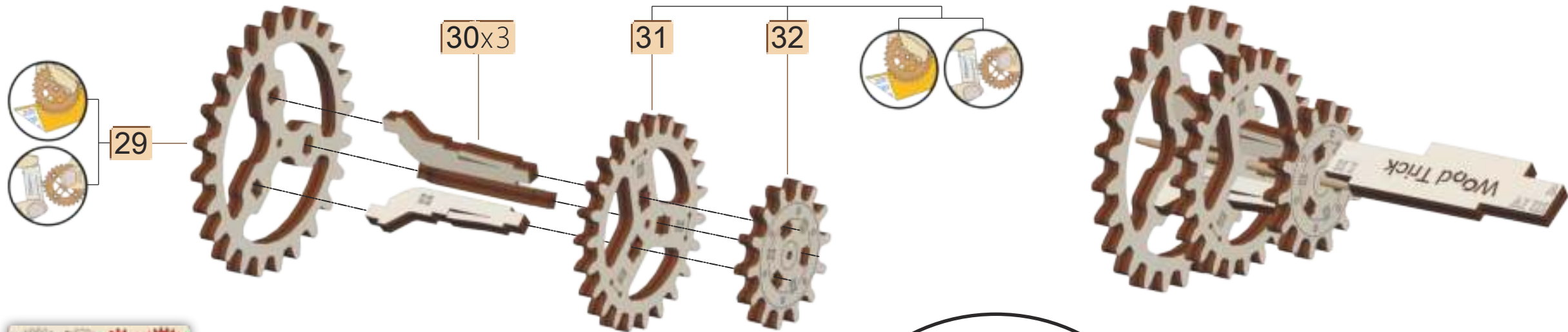



5



25

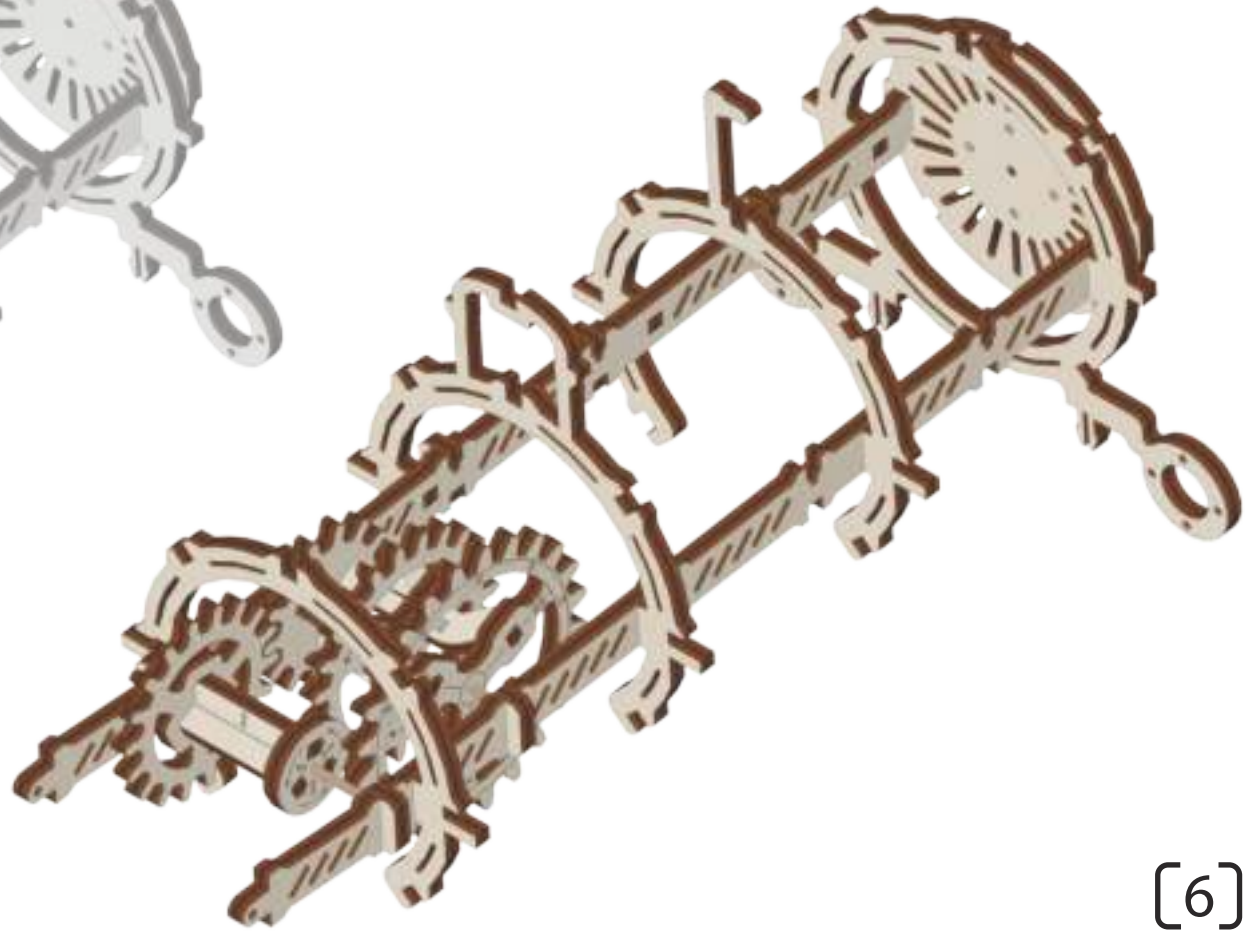

[6]

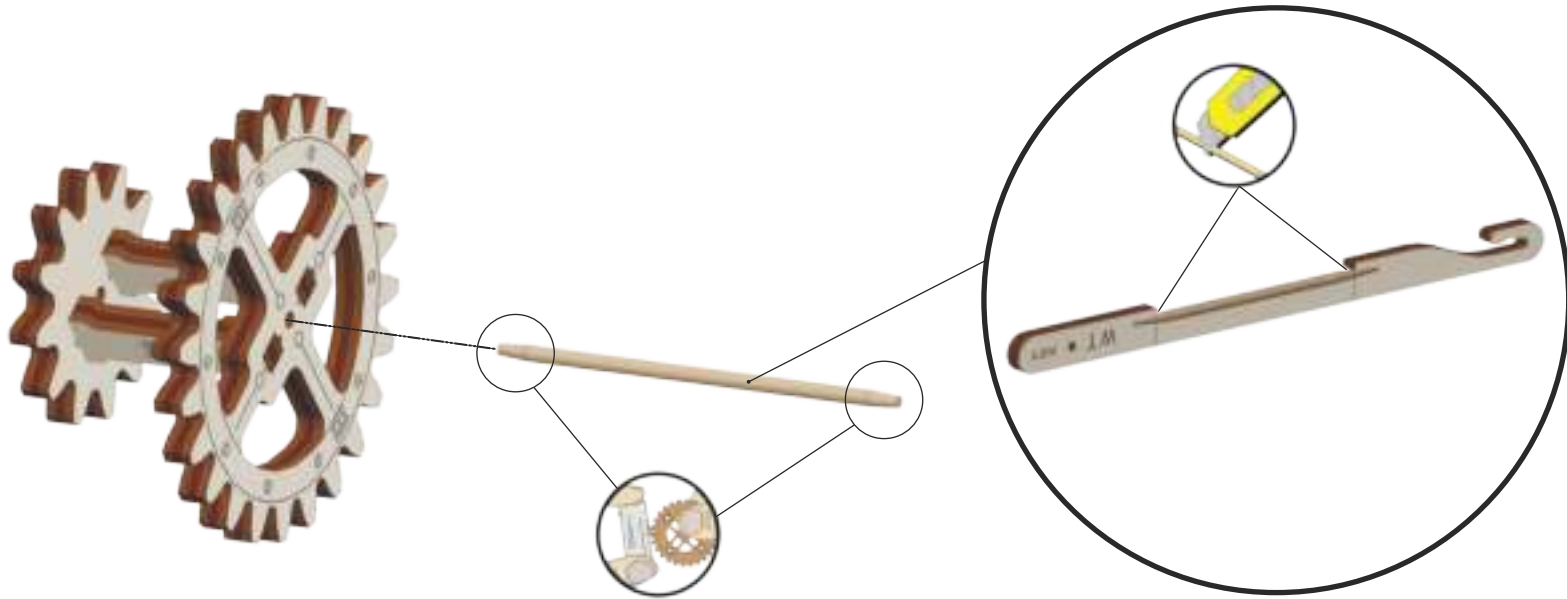
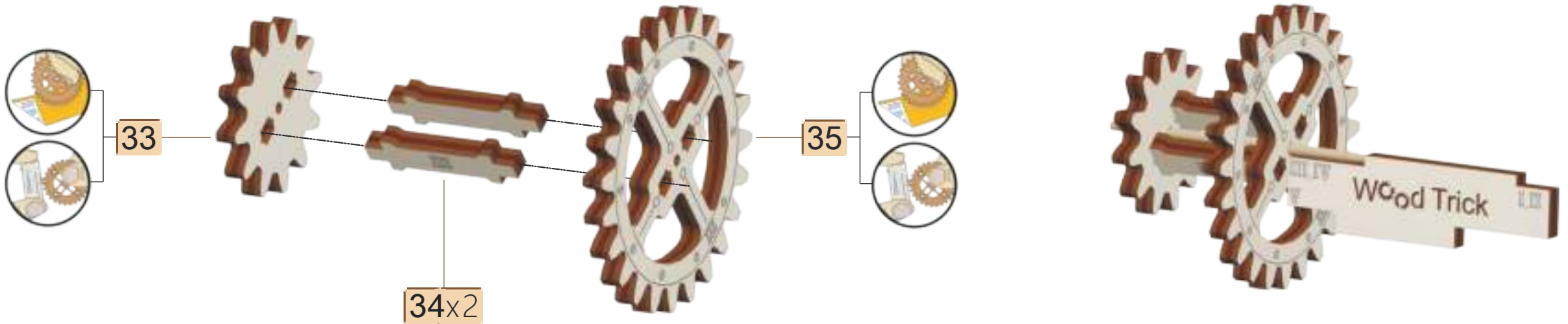





5

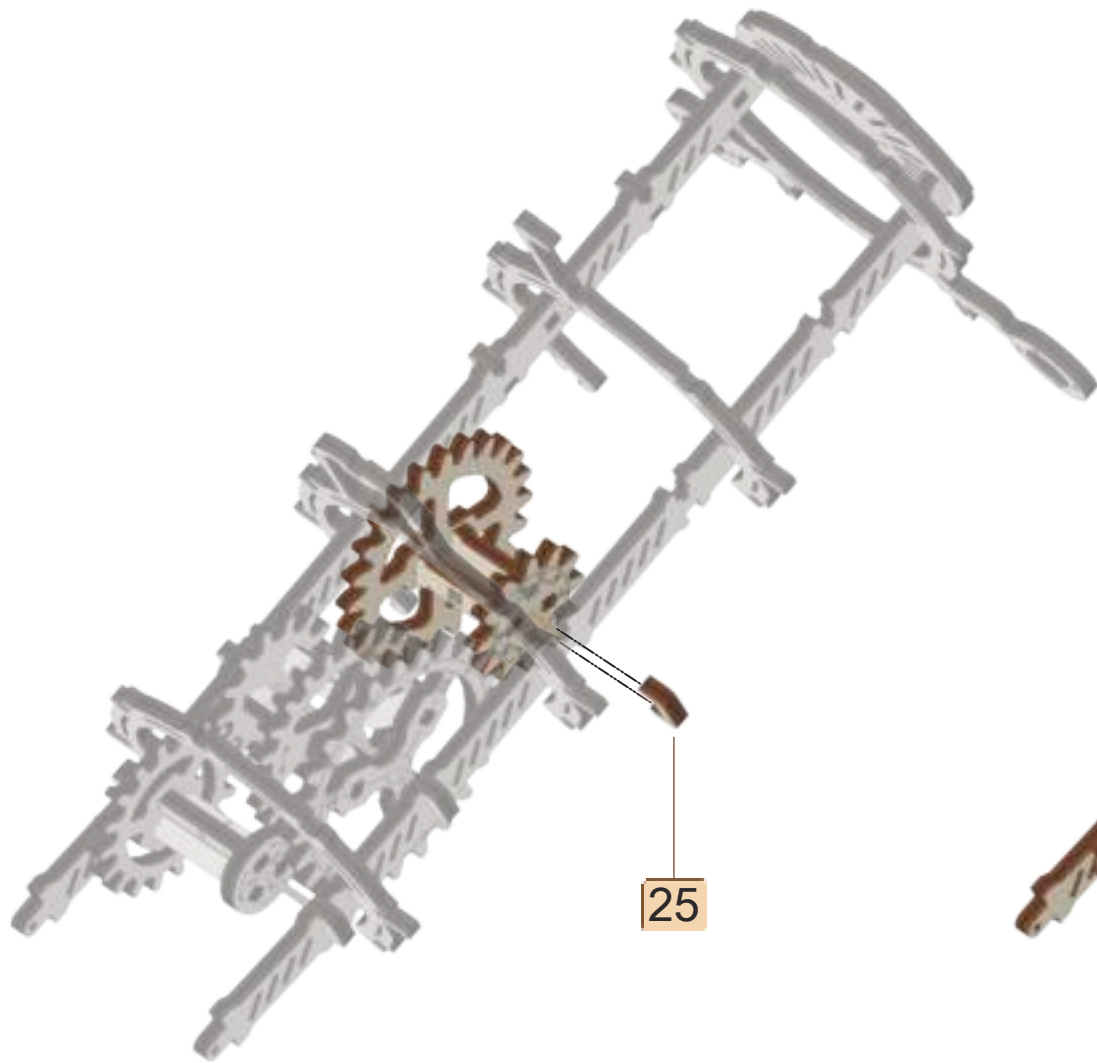

25

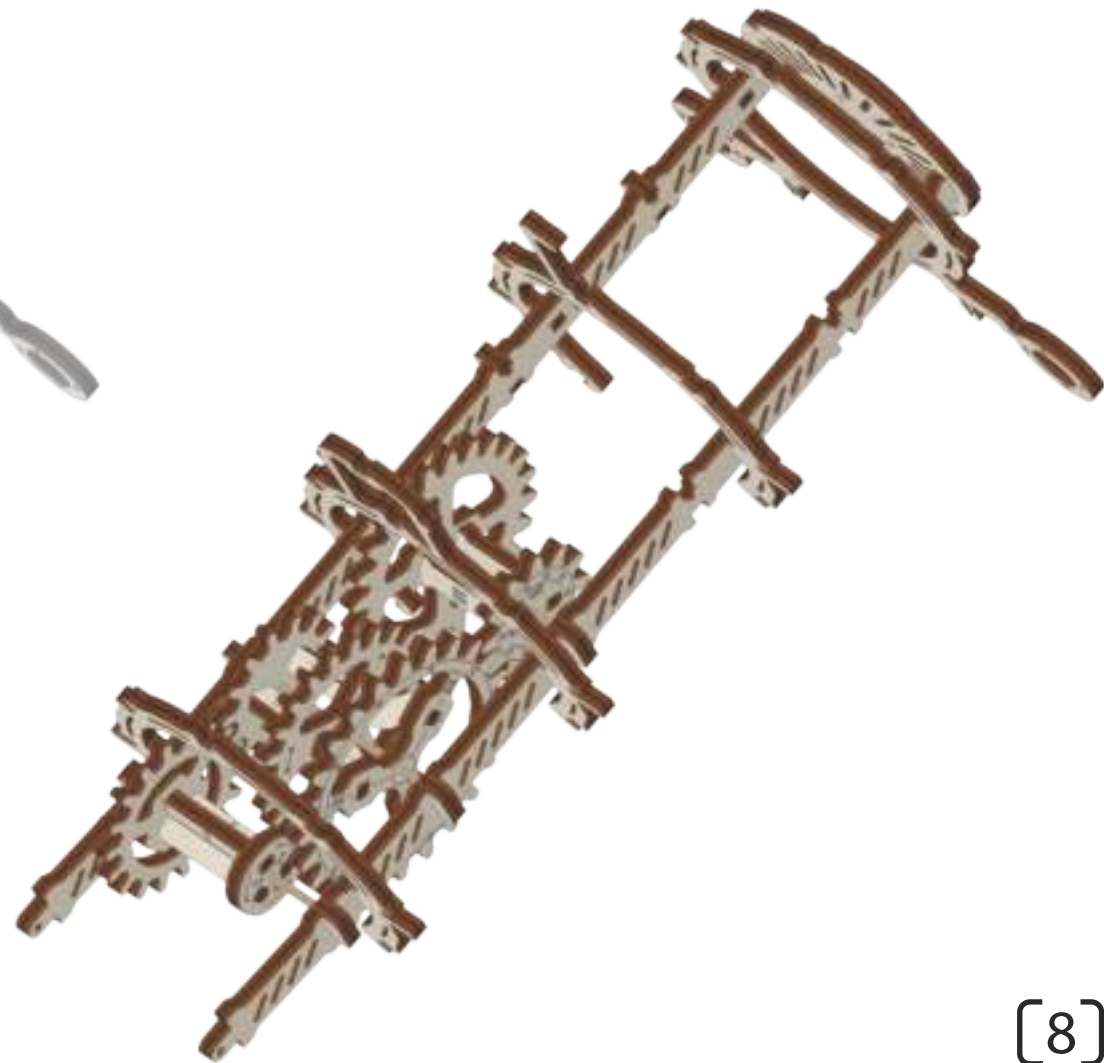

[8]

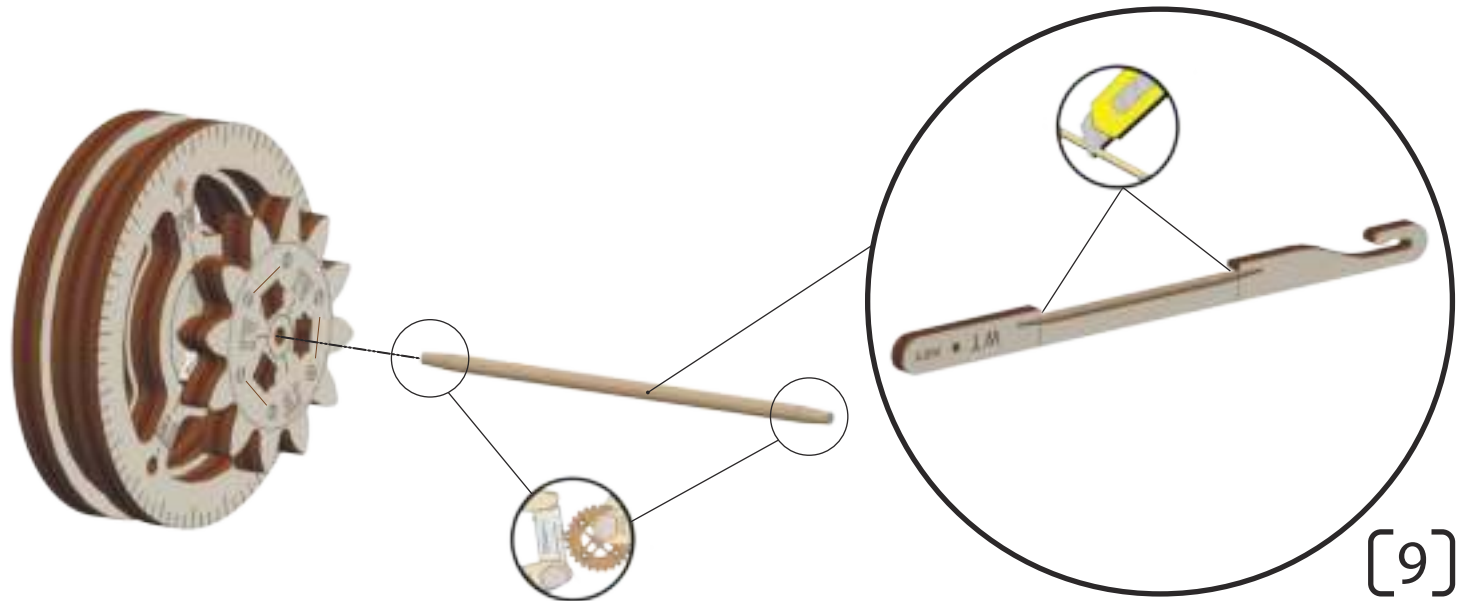
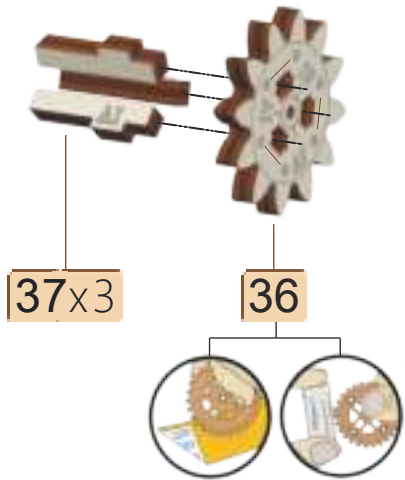
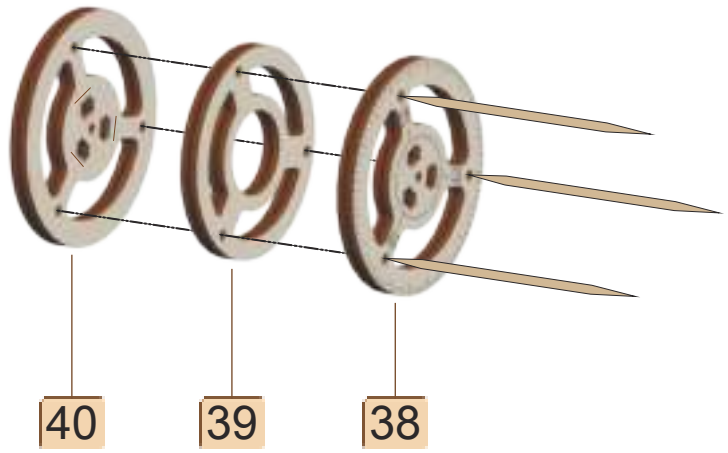



5

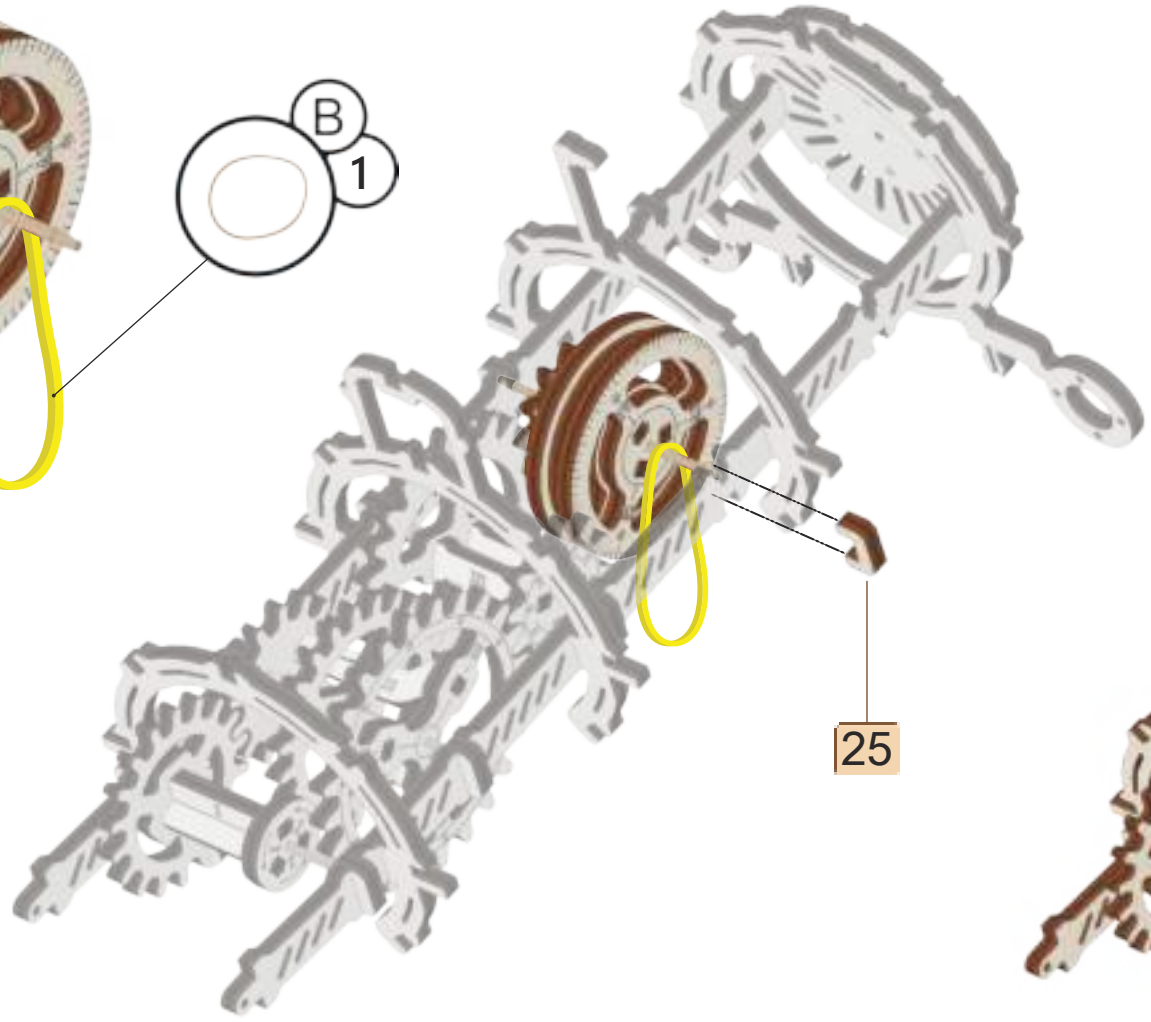
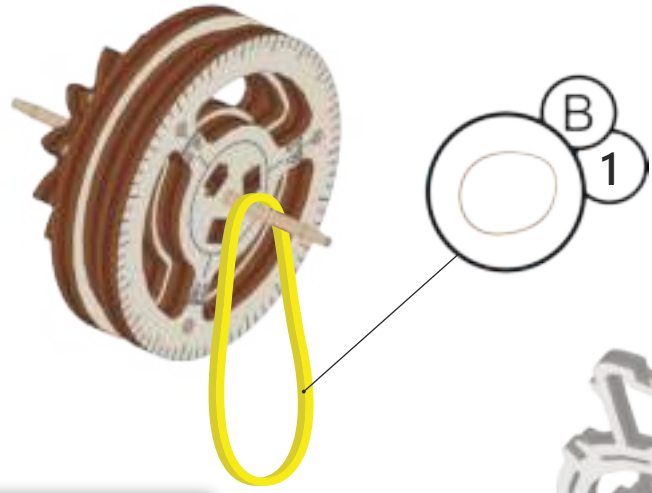

25

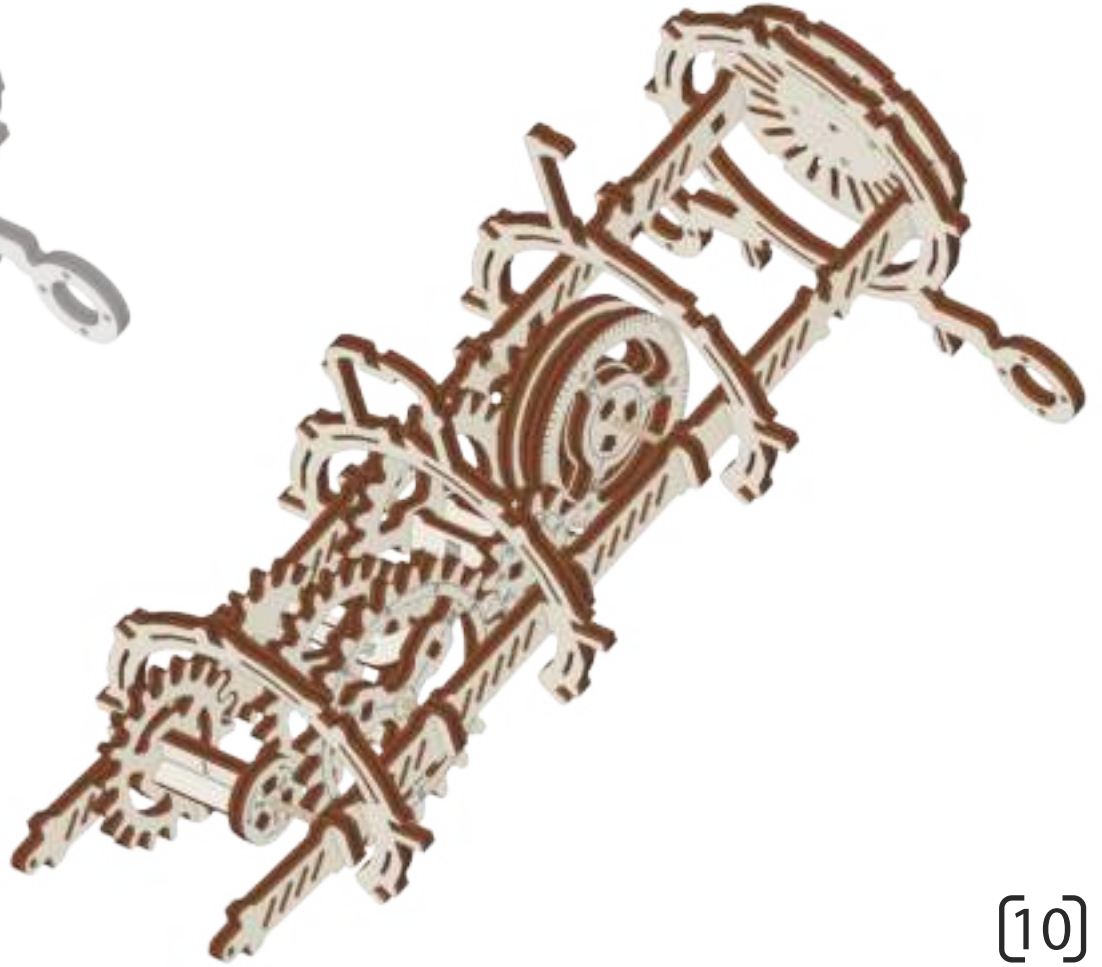

[10]

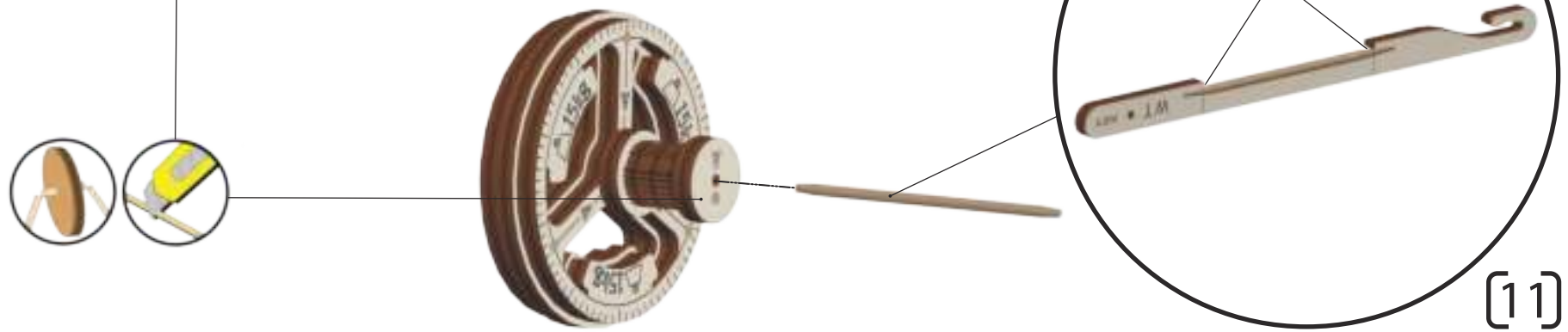
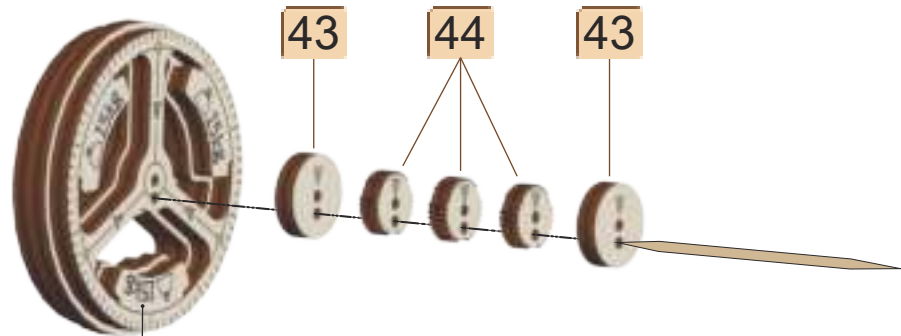
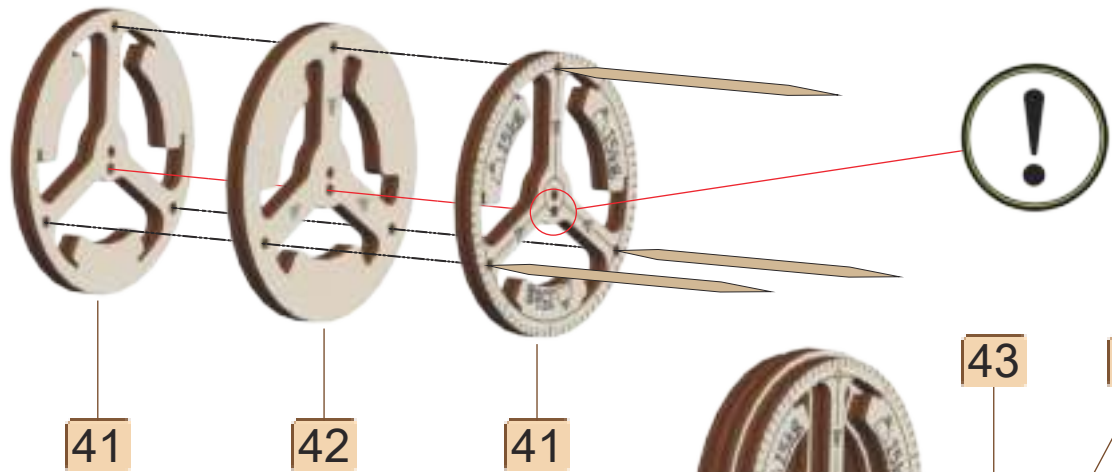

3

11

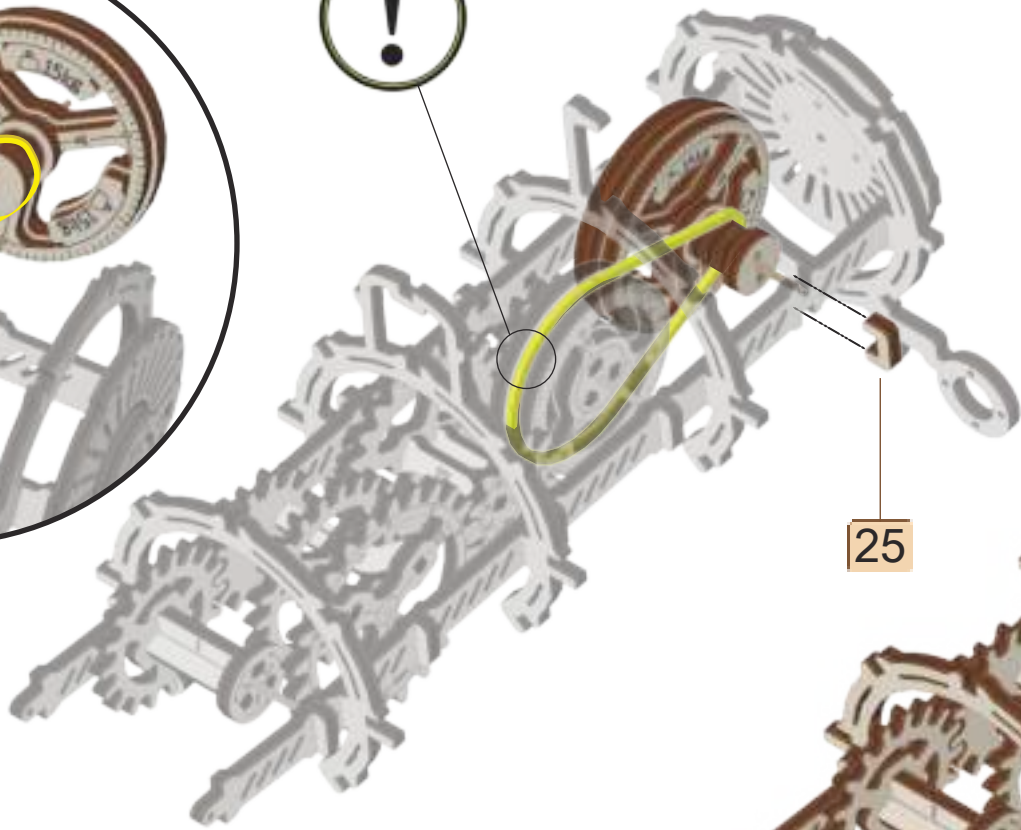
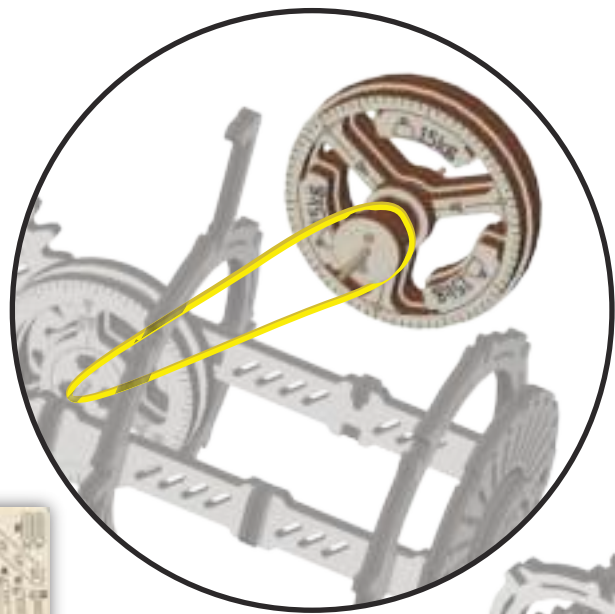

25

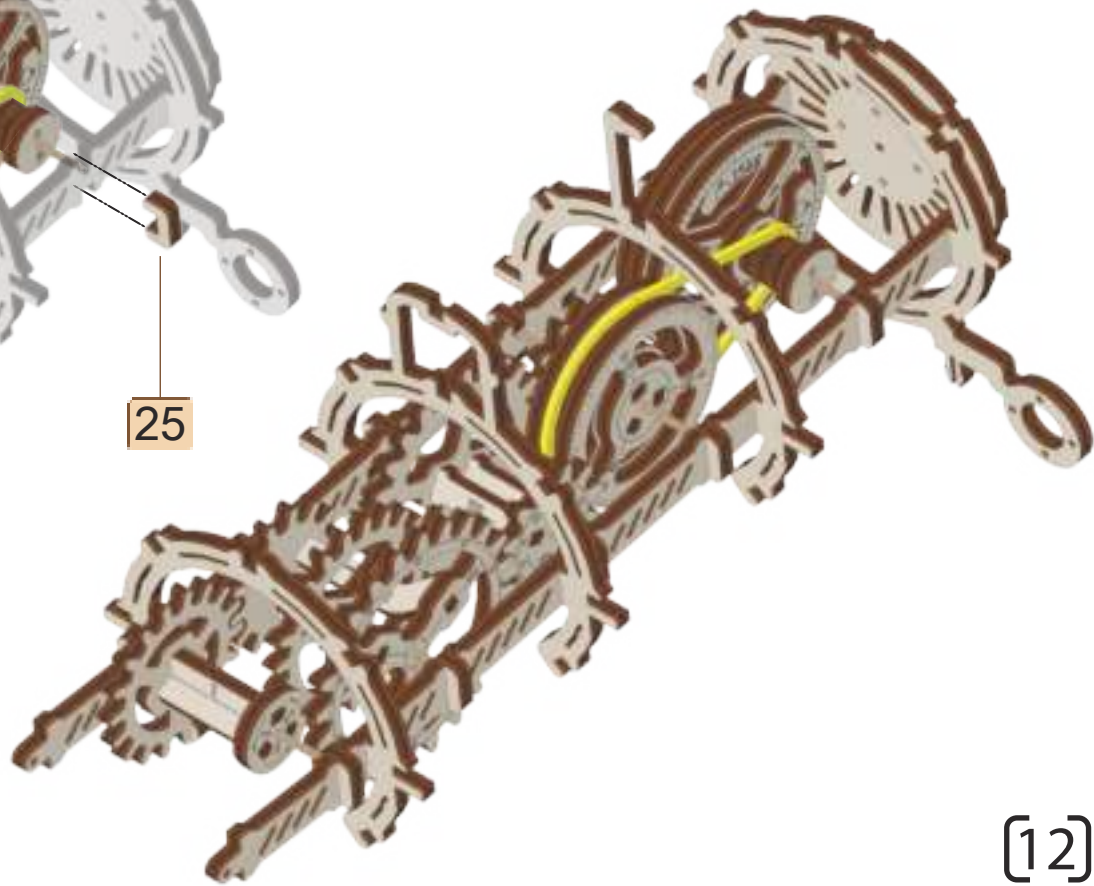

[12]



5

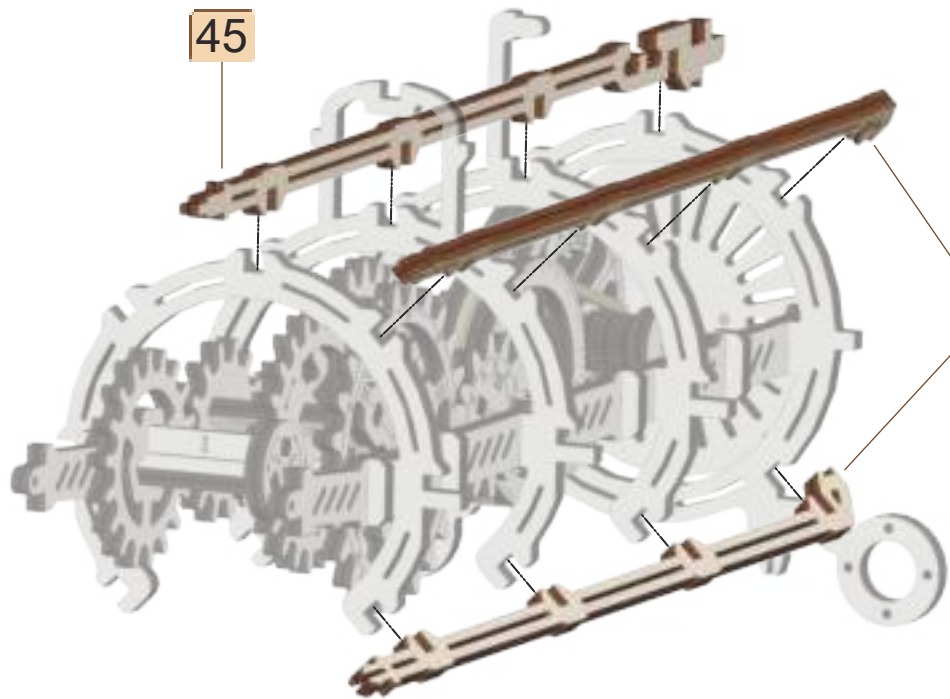

45

22

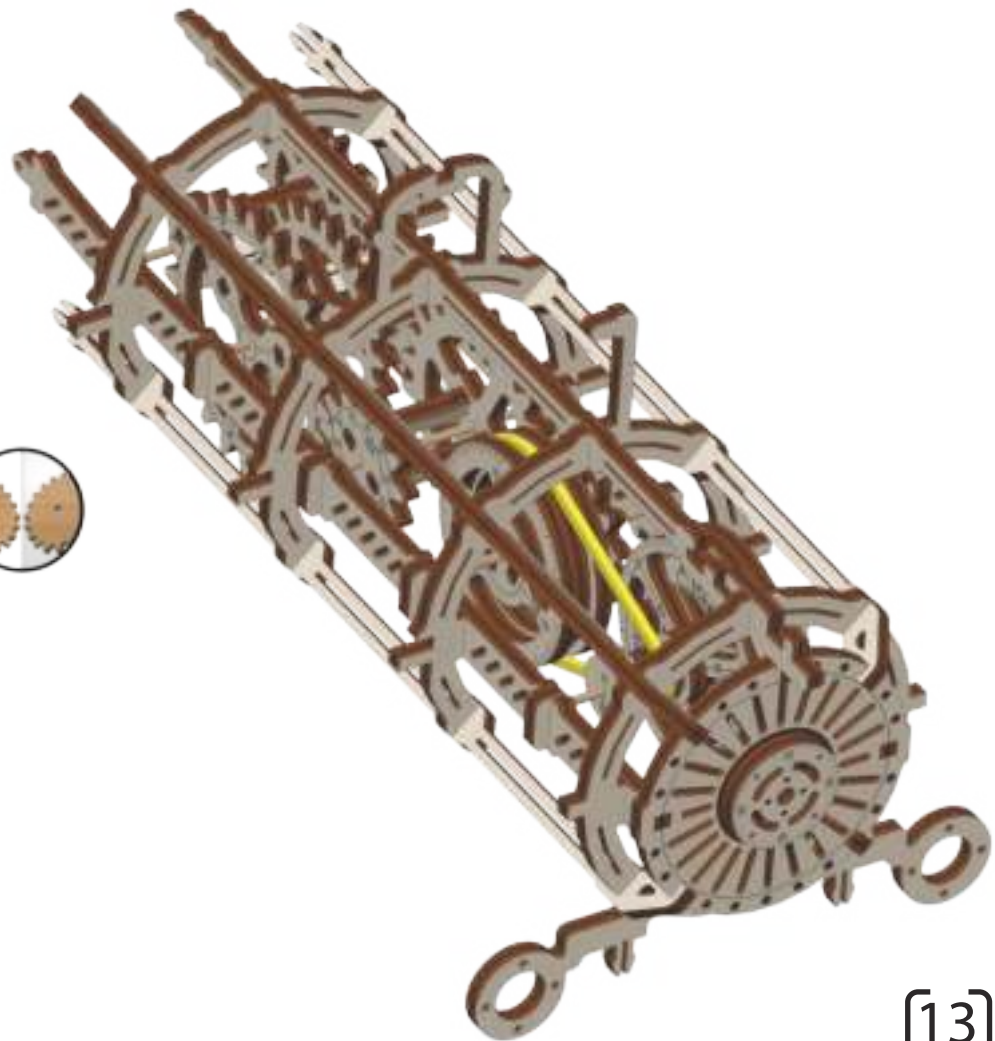
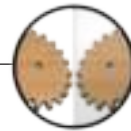

[13]



3

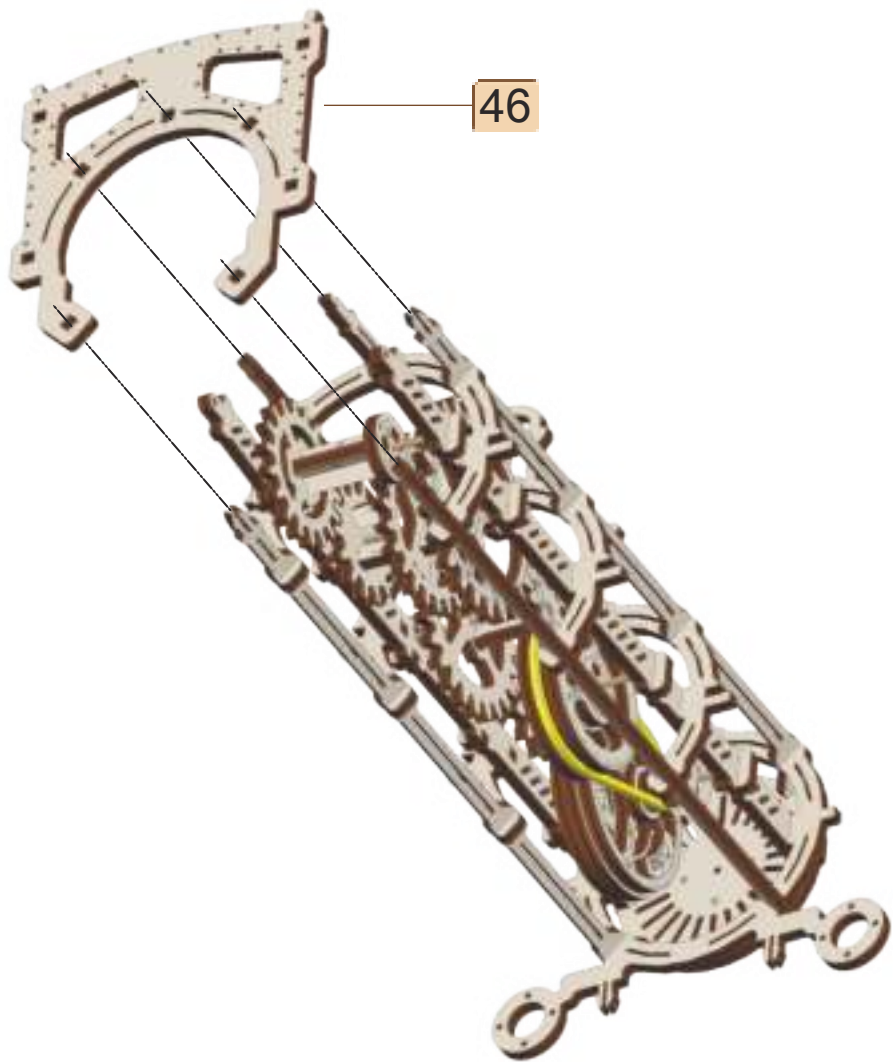

46



[14]

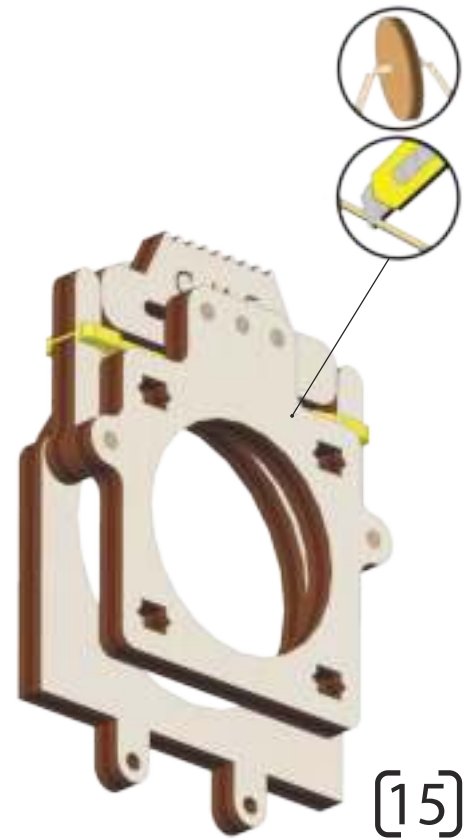
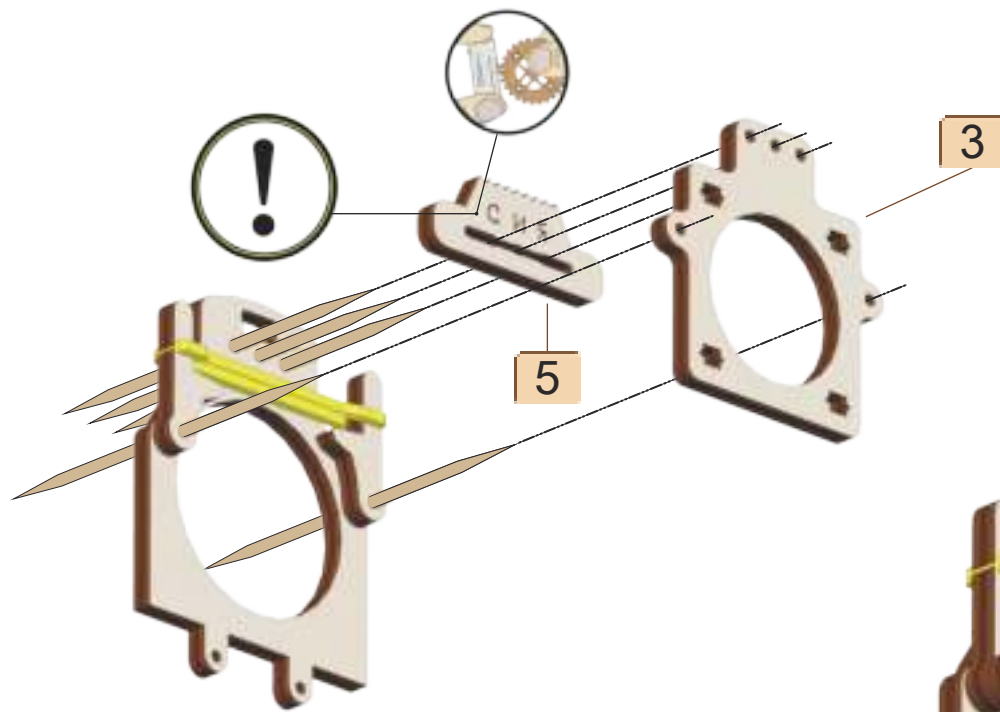
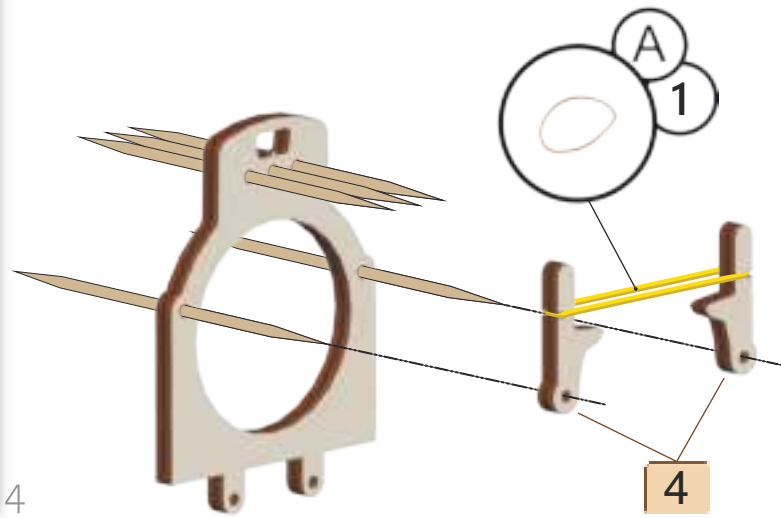
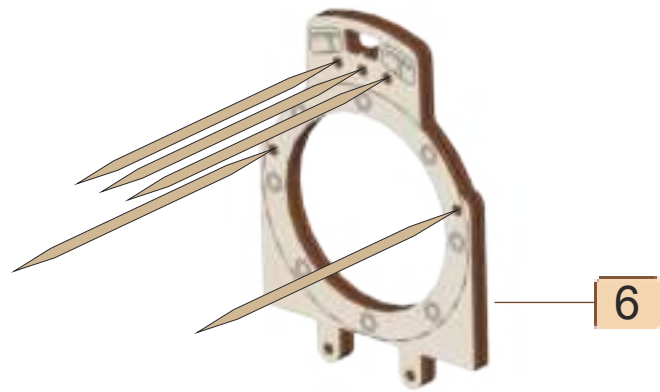



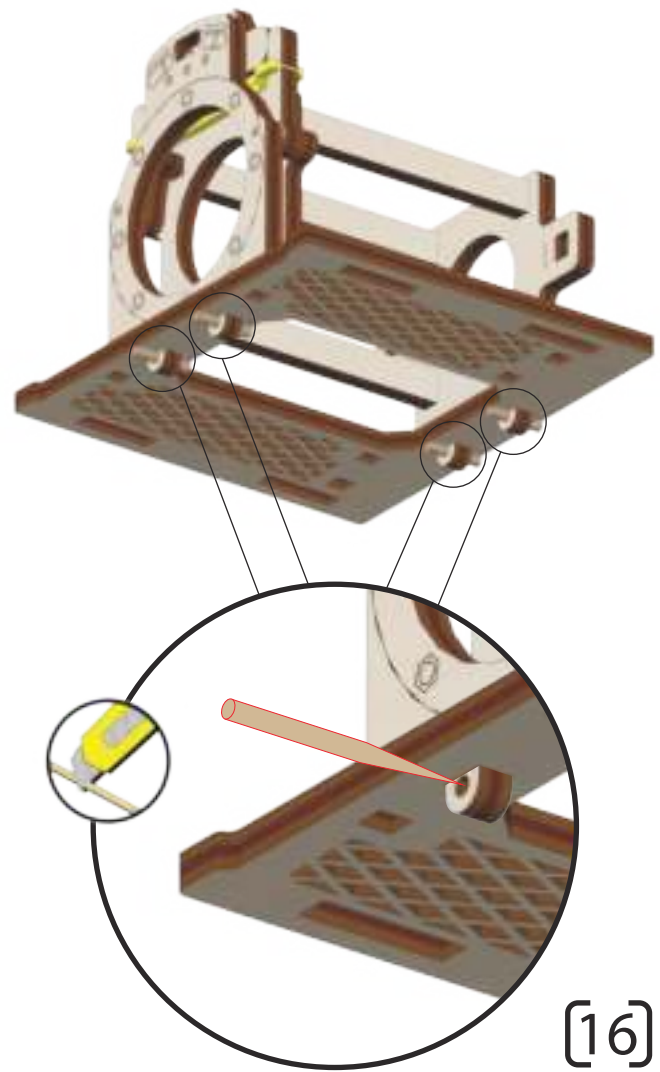
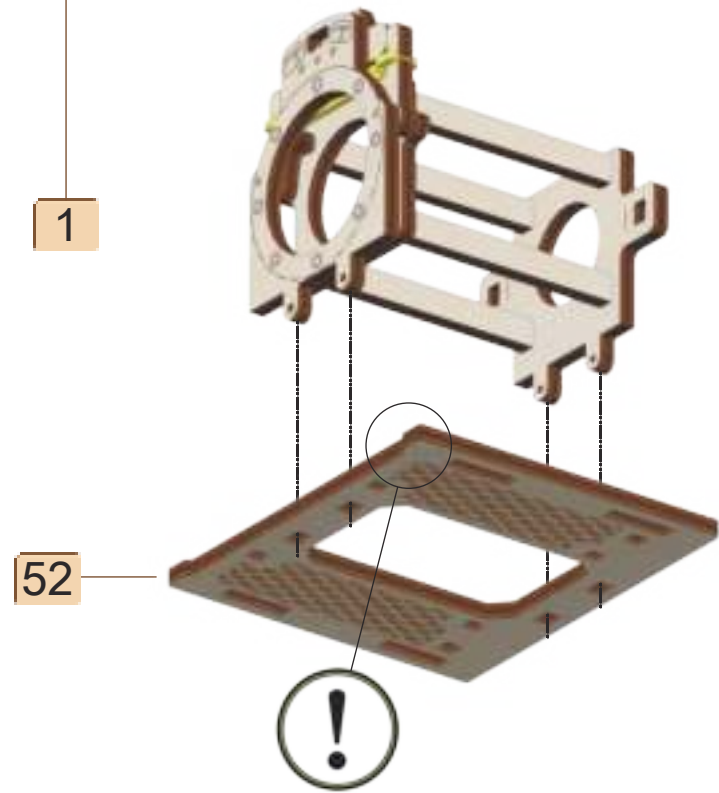
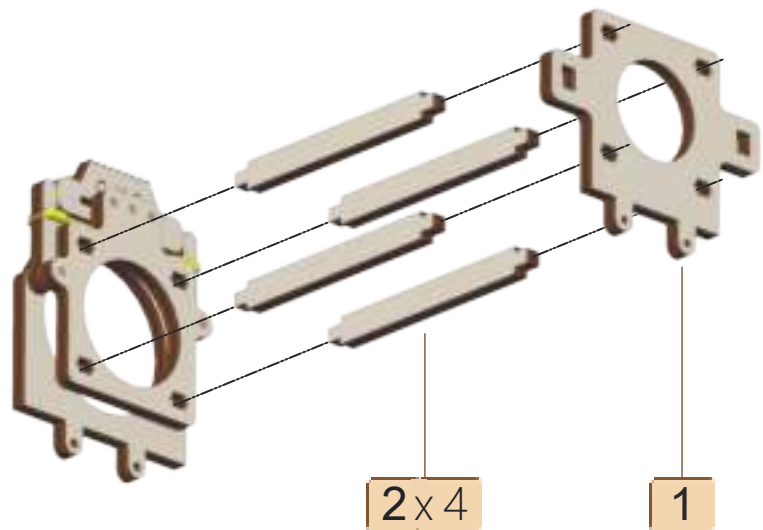
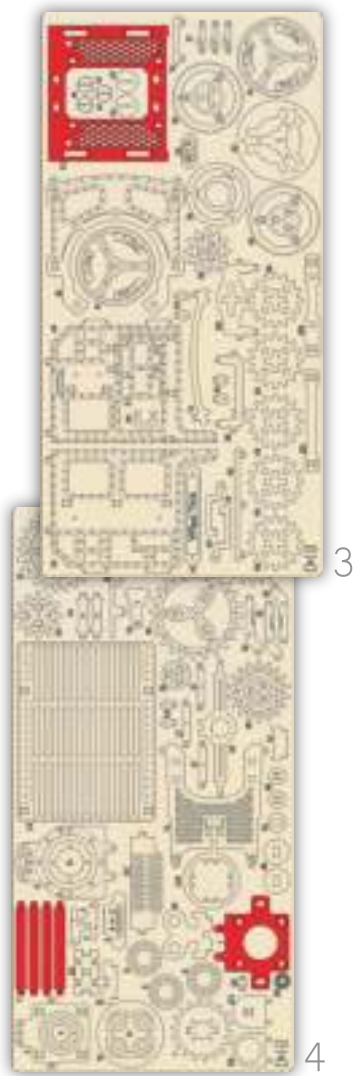



4

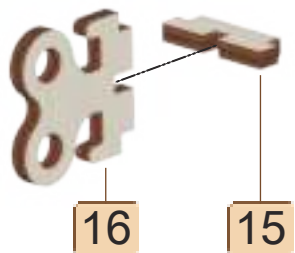

16

15

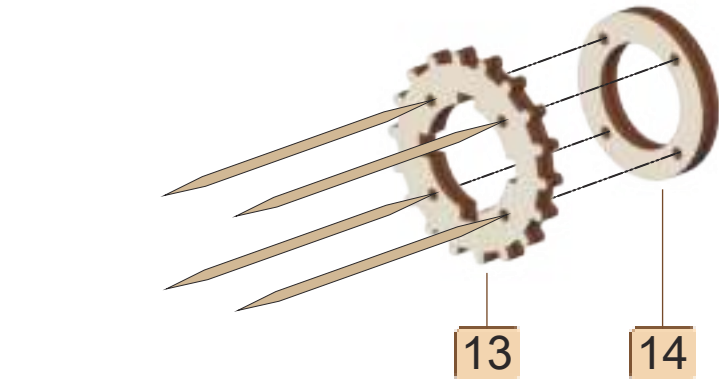

13

14



7

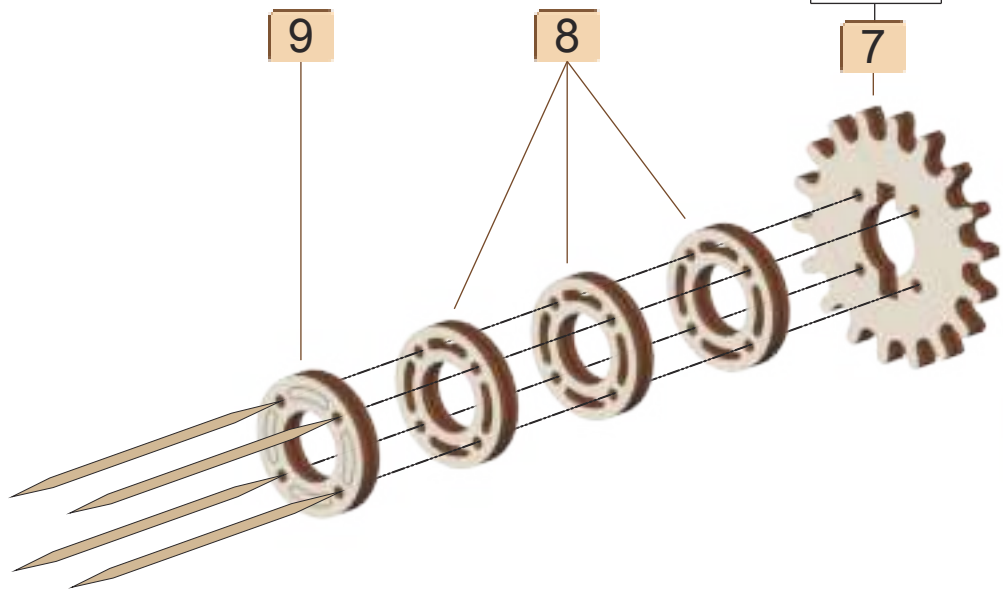

9

8

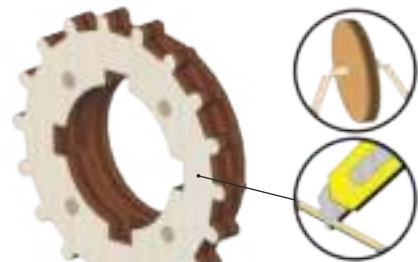

10



11x4



11x4

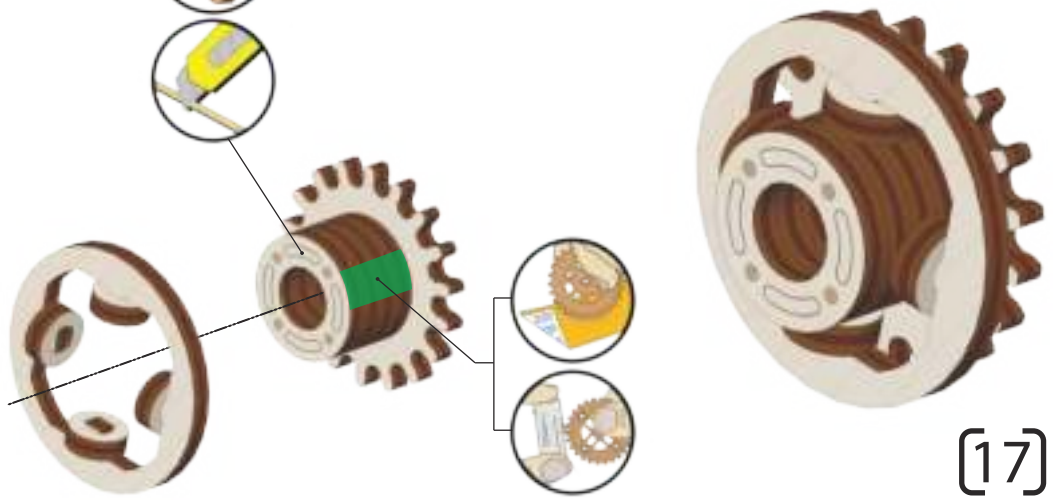
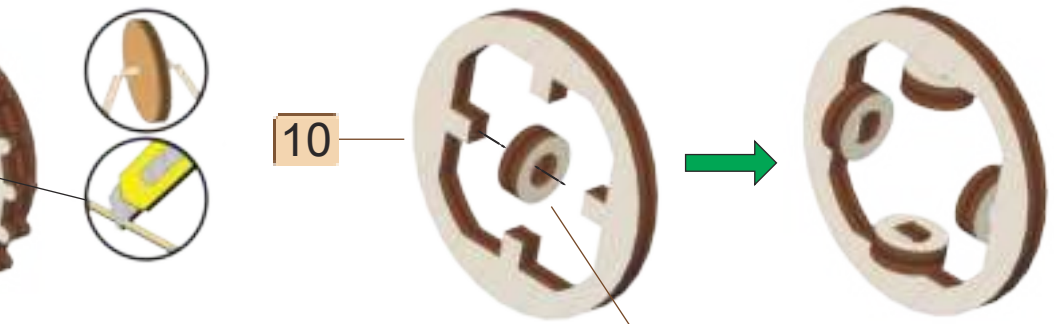

[17]

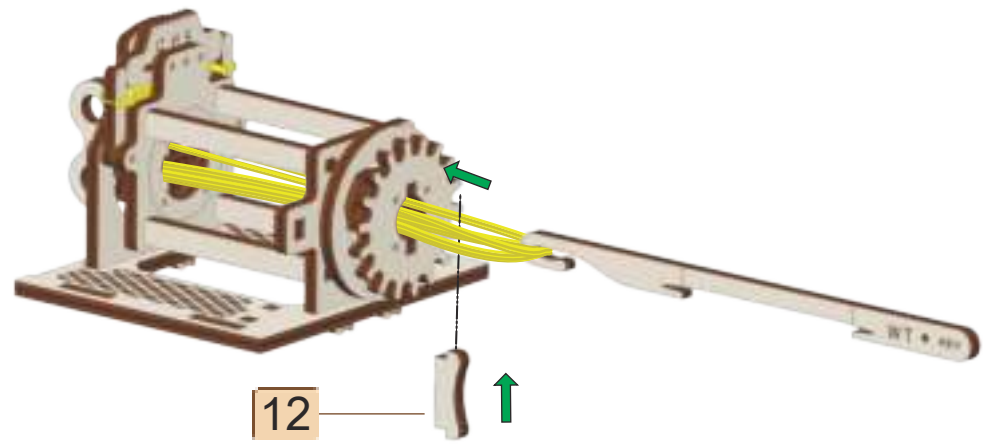
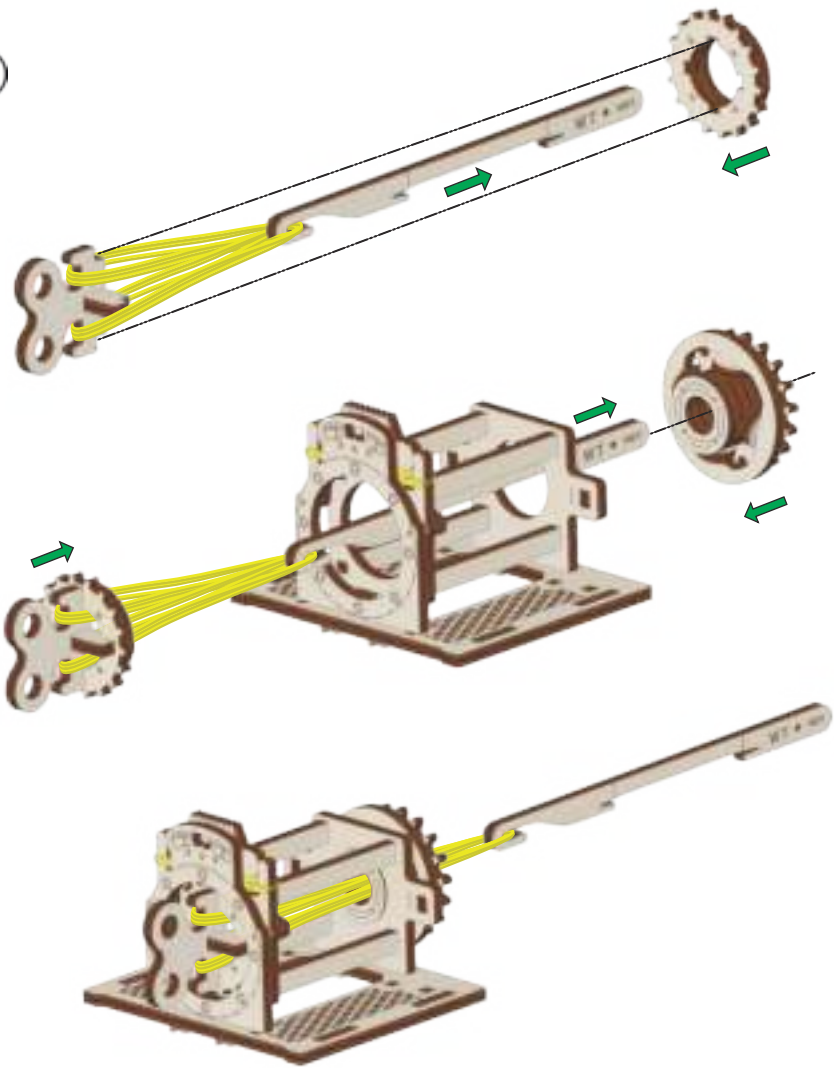
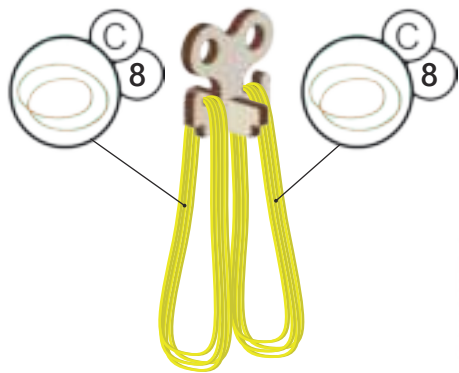

4

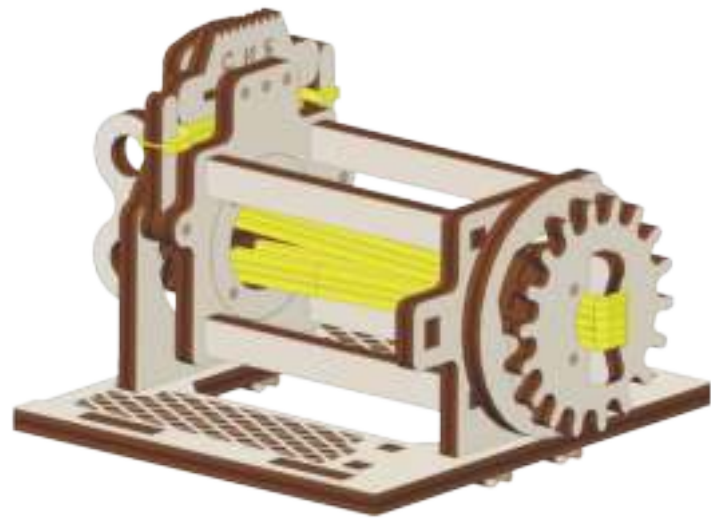

[18]

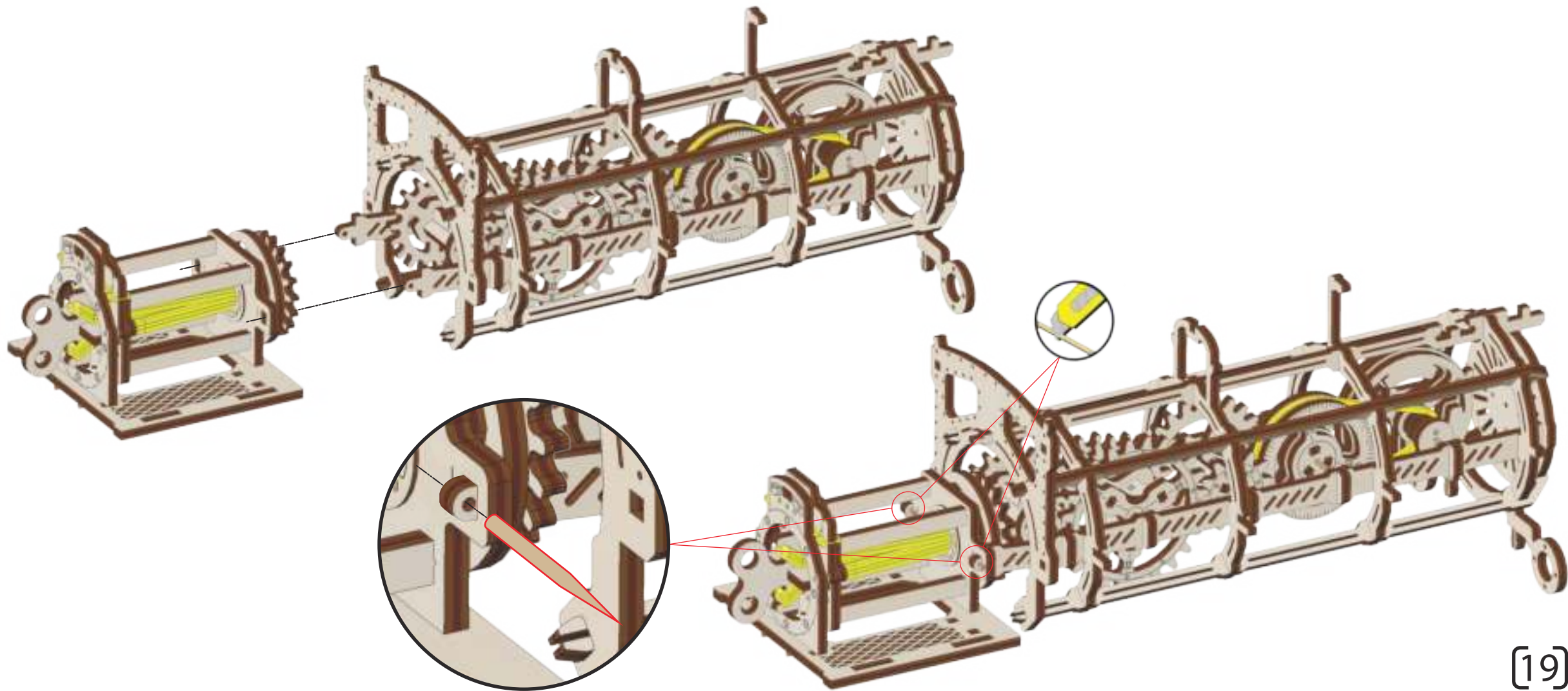

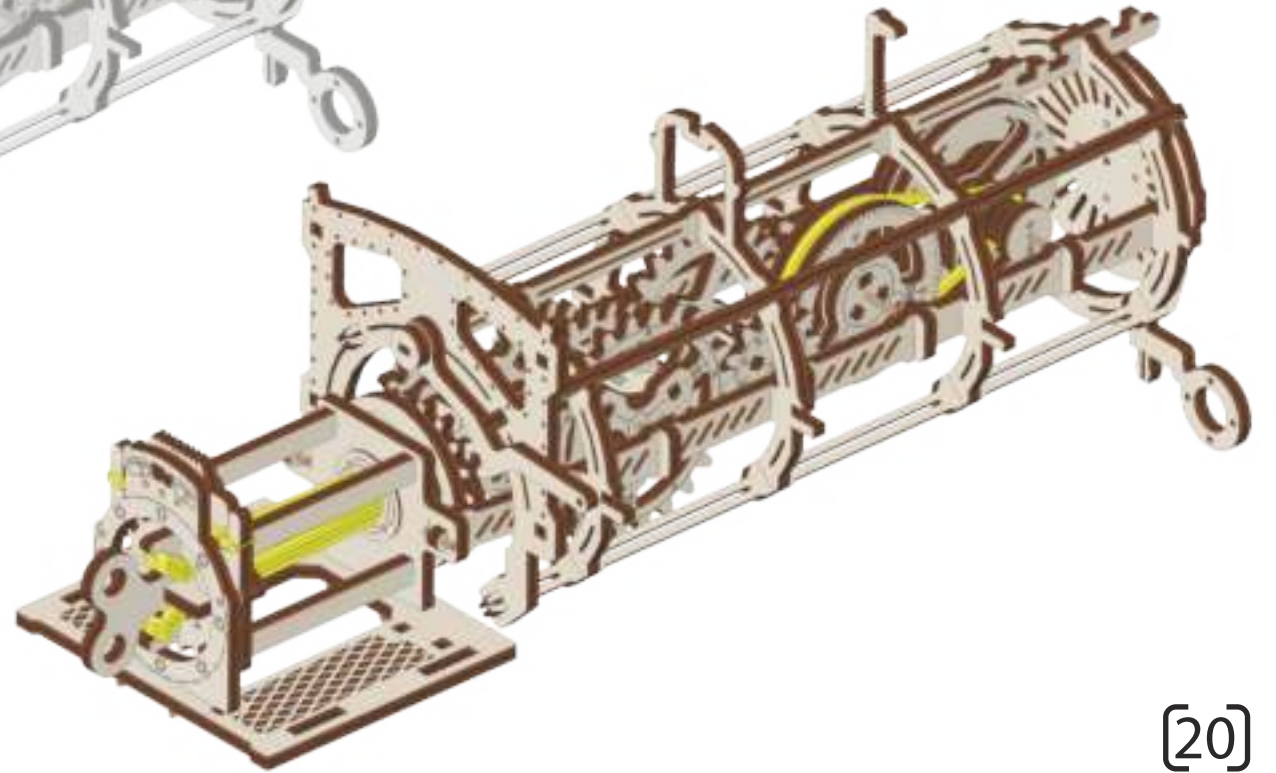
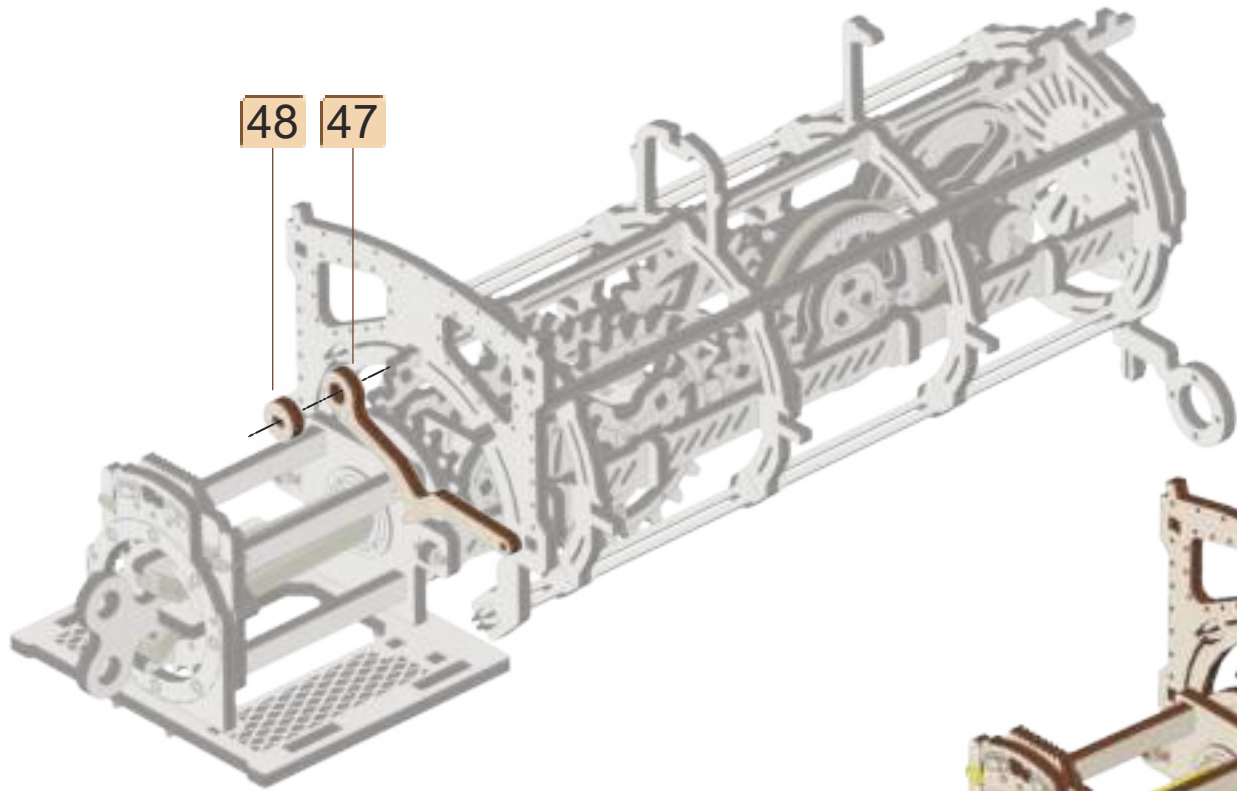

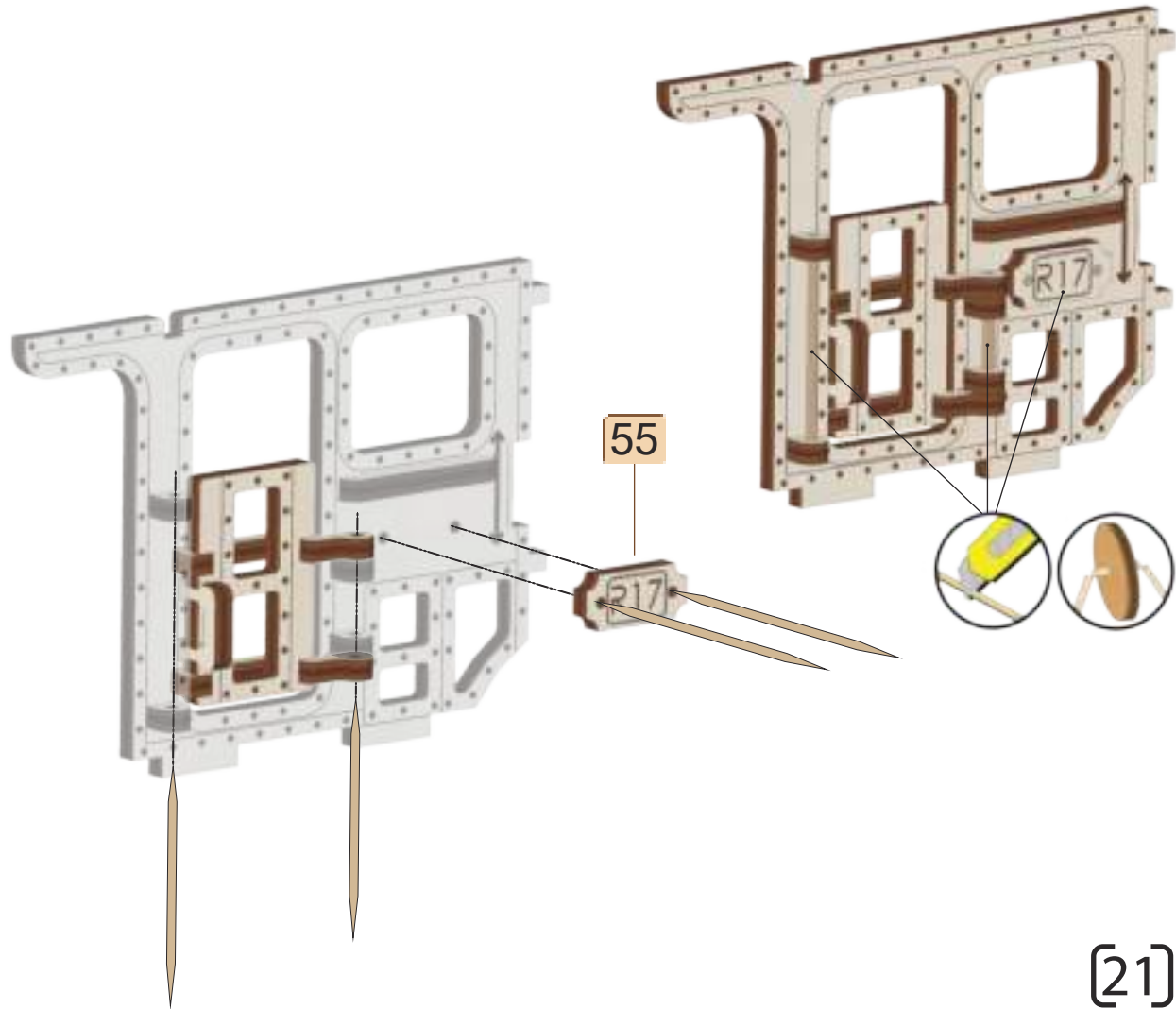
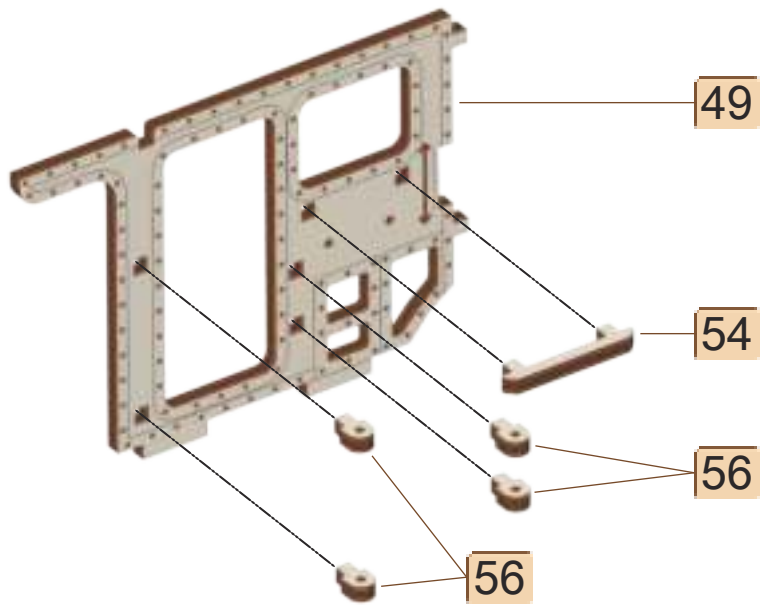
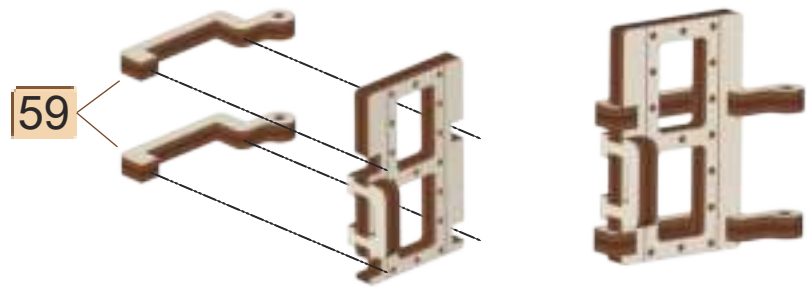
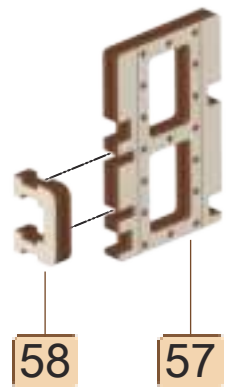

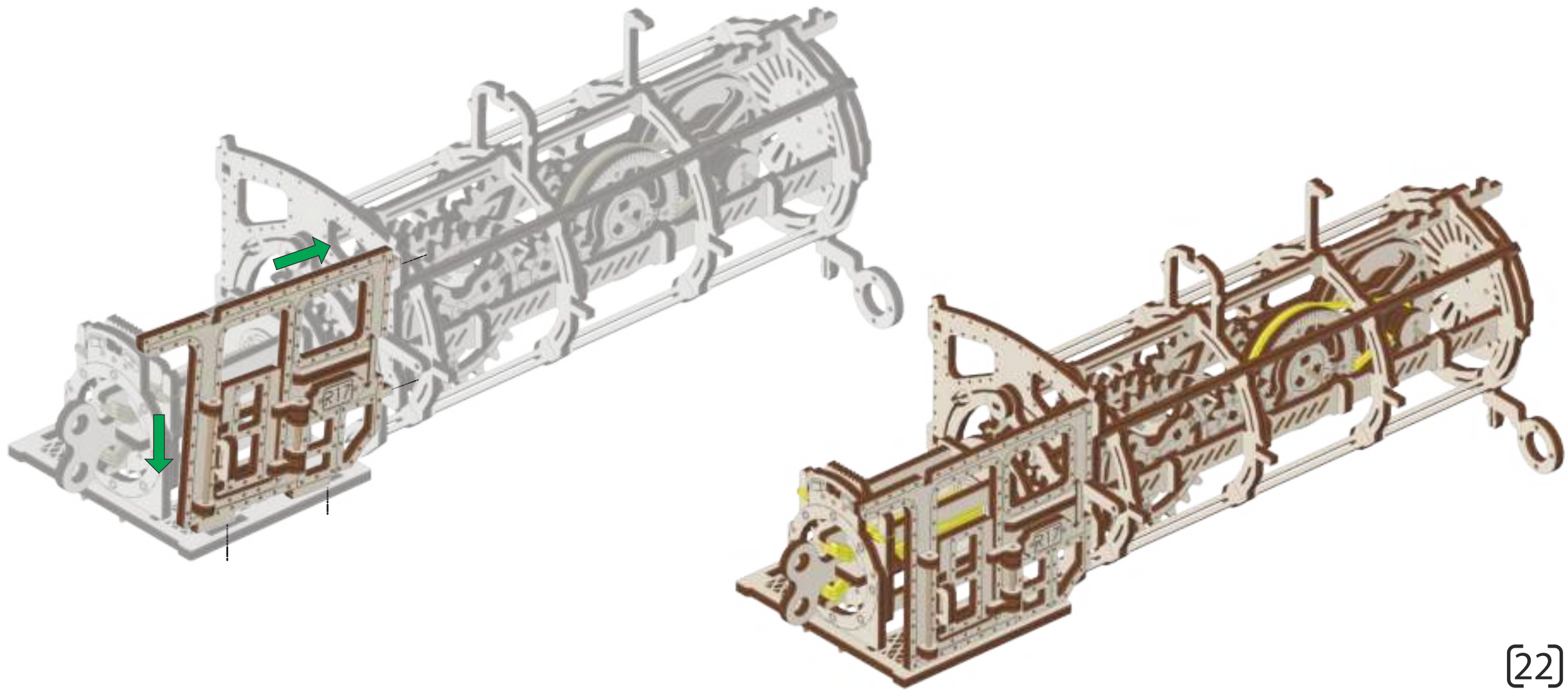

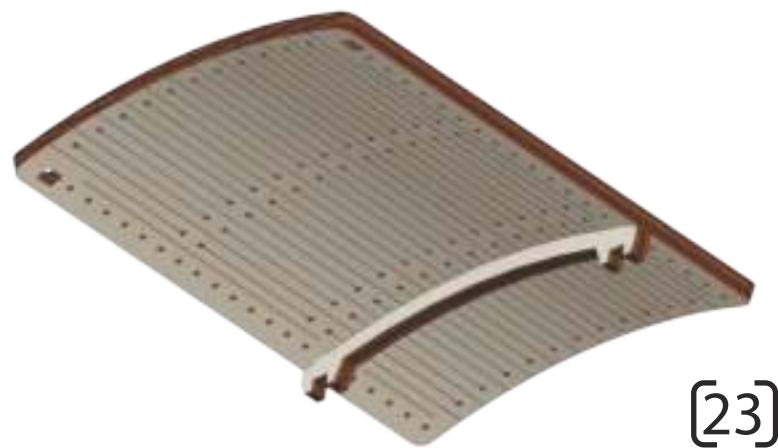
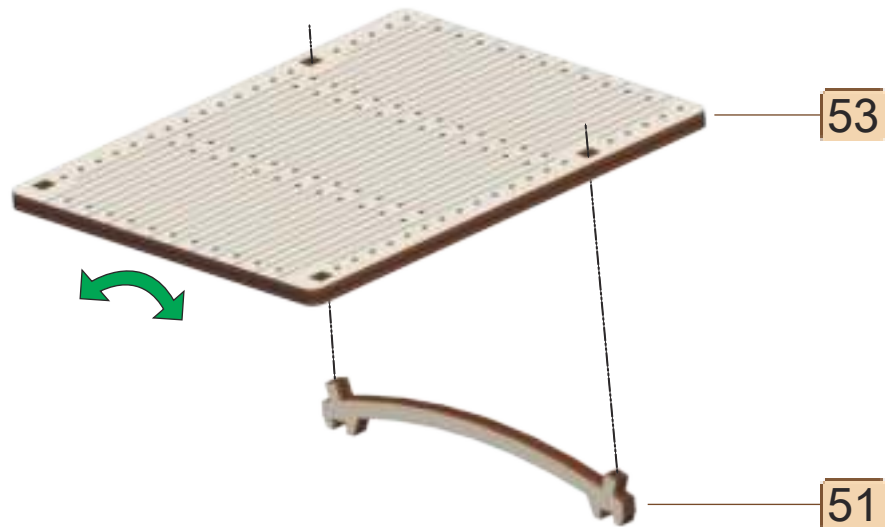
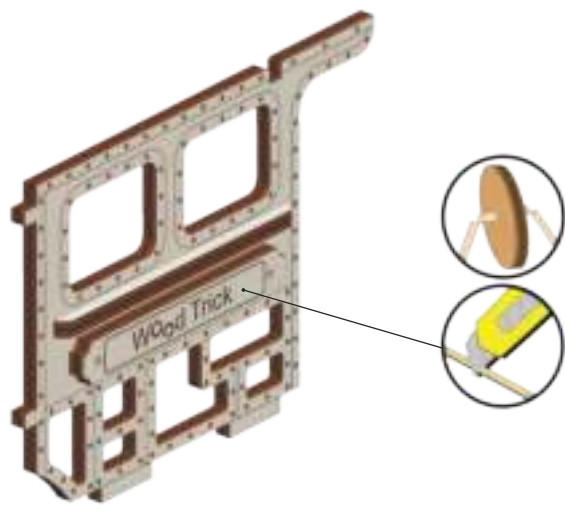
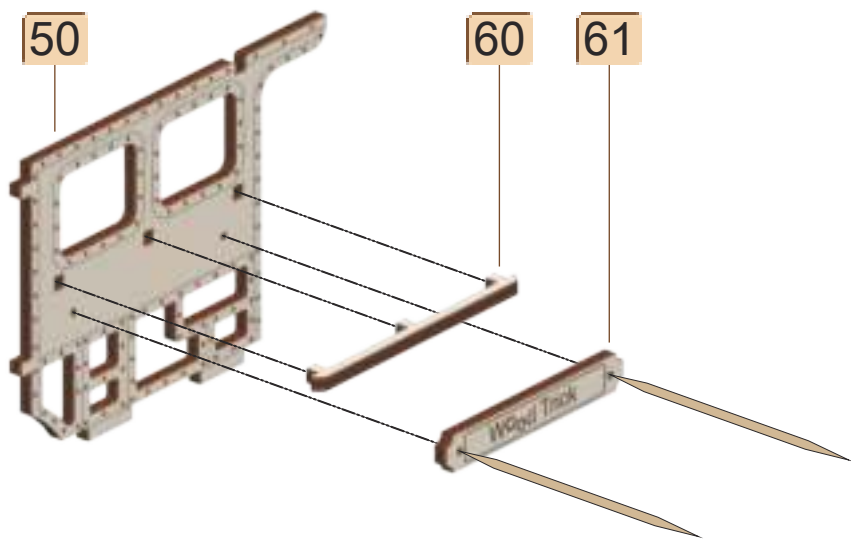
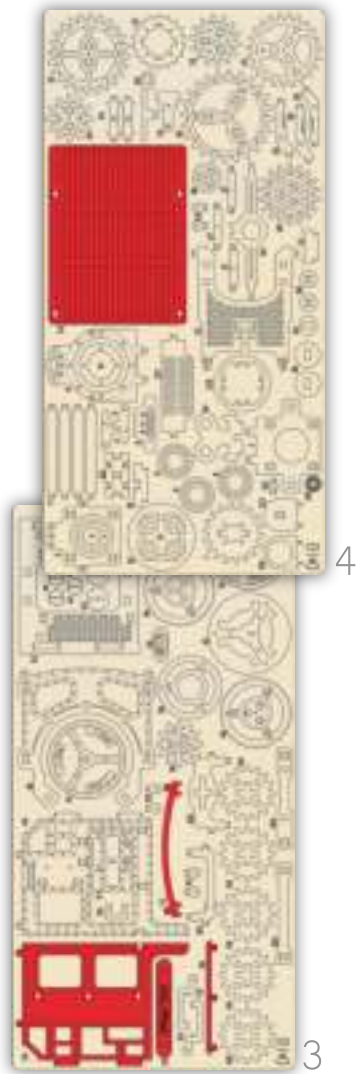



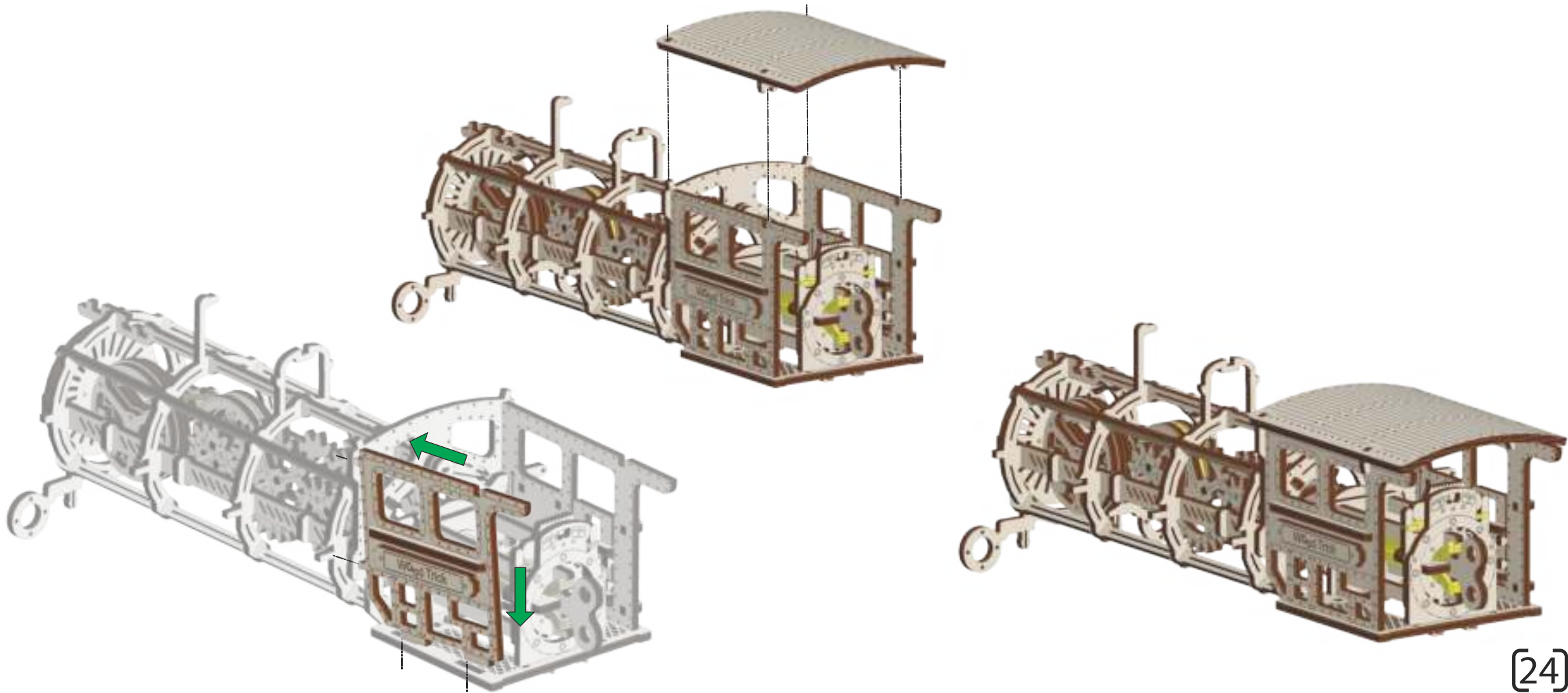

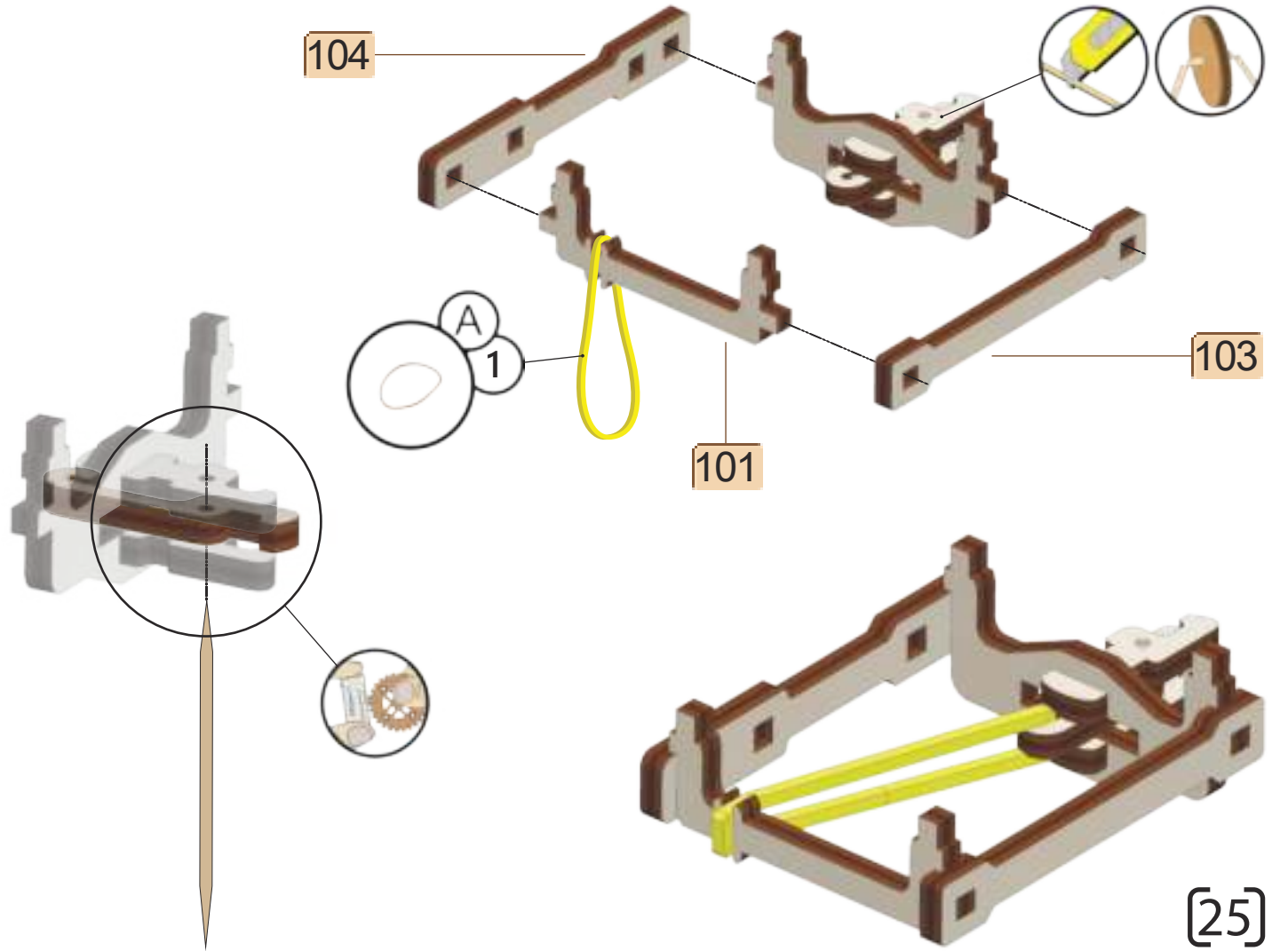
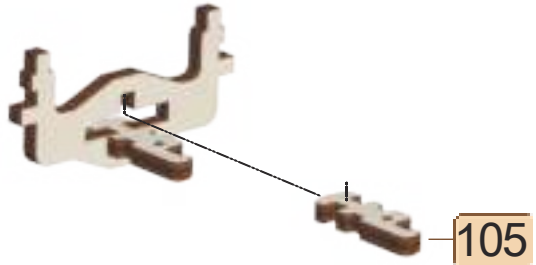
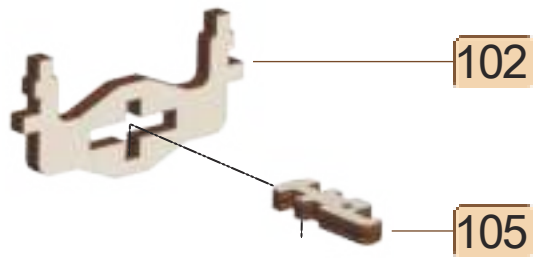
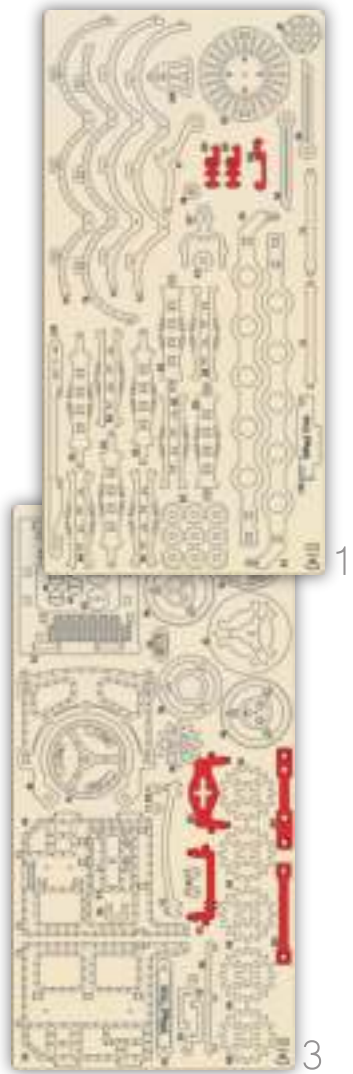

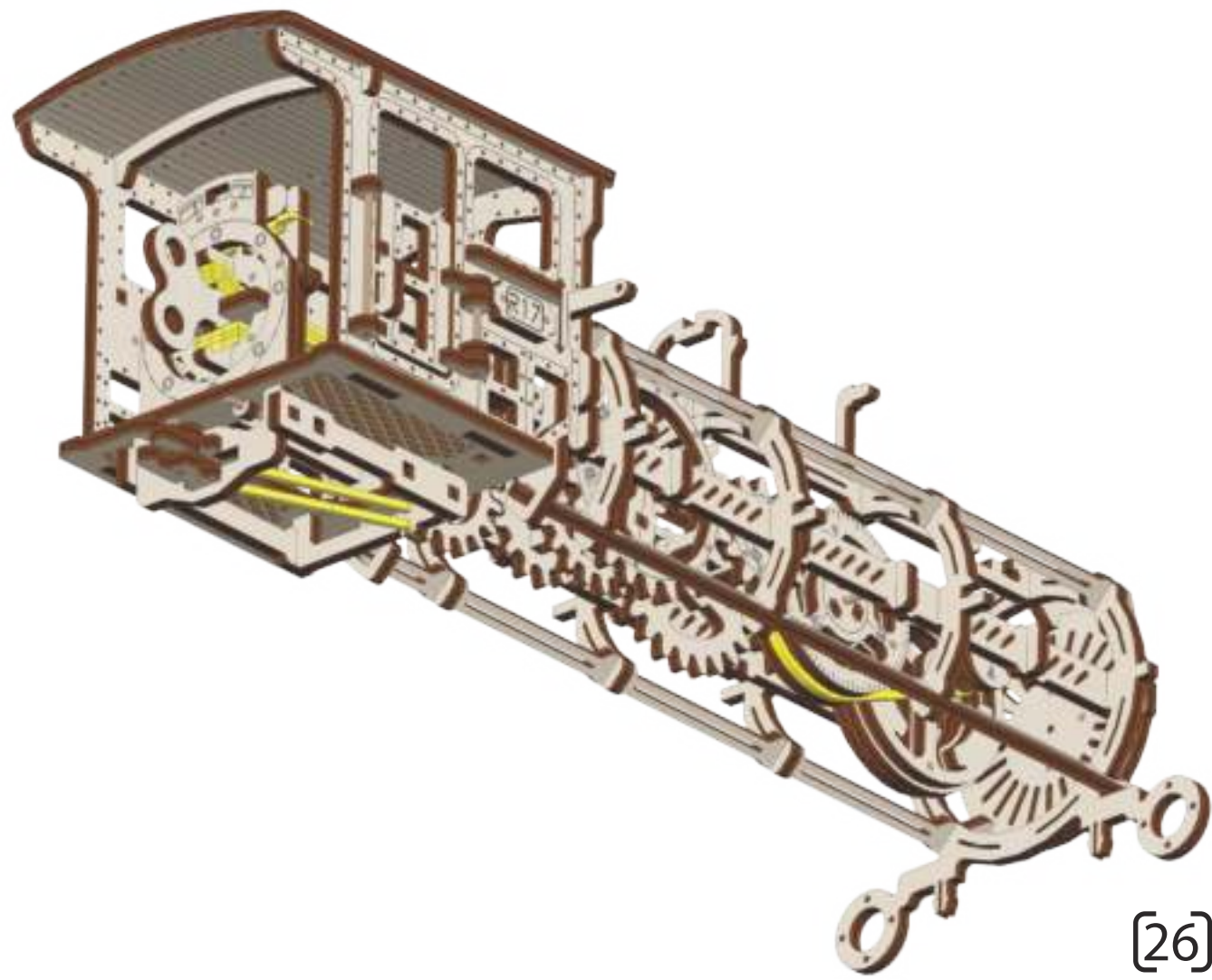
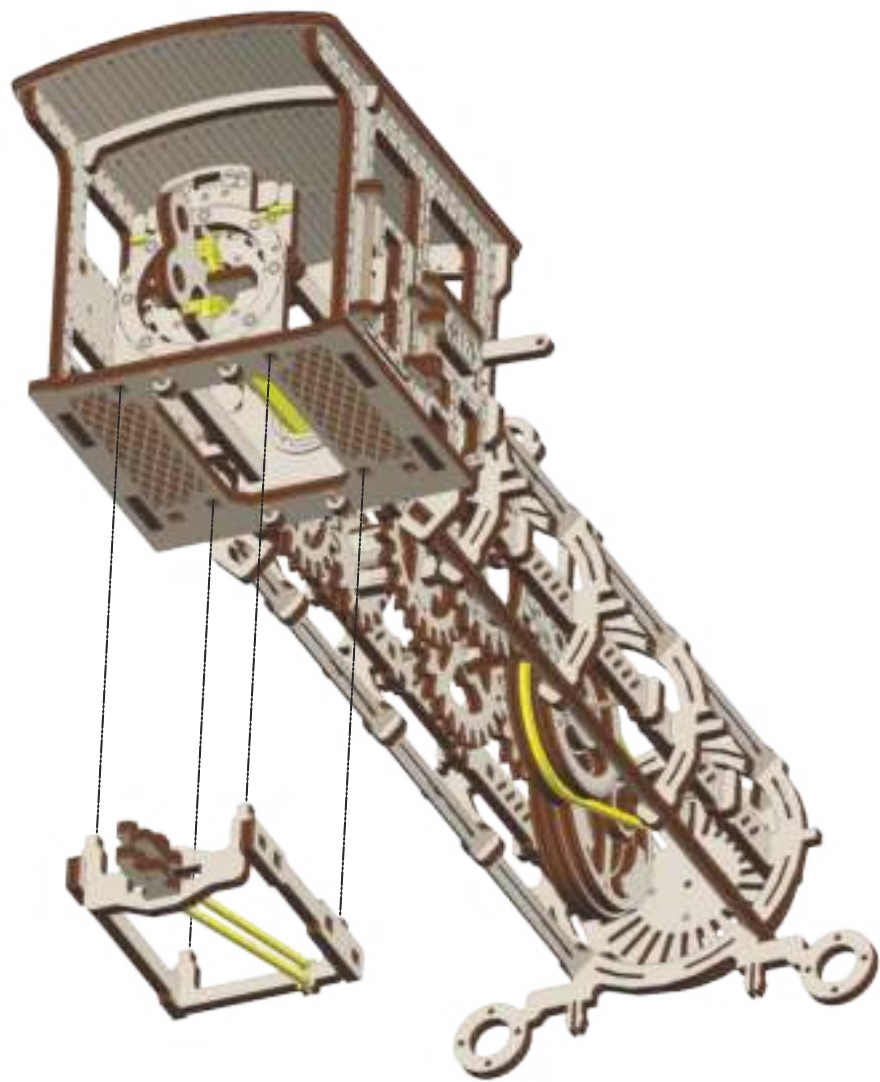

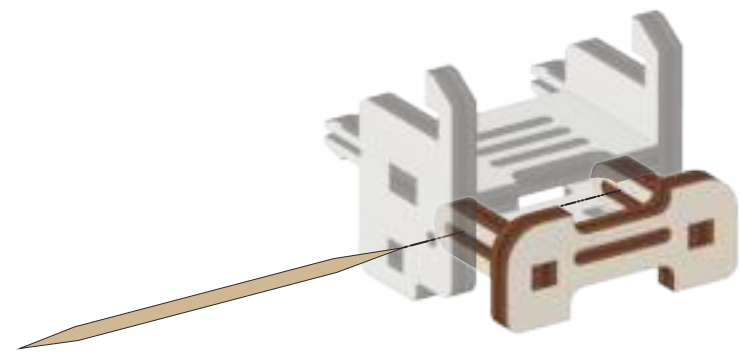
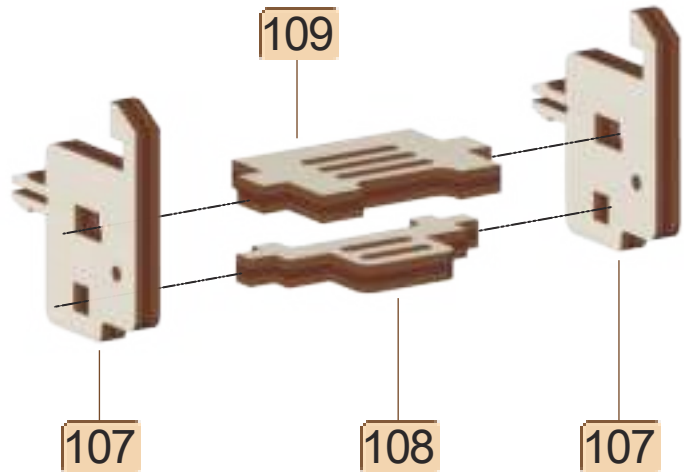
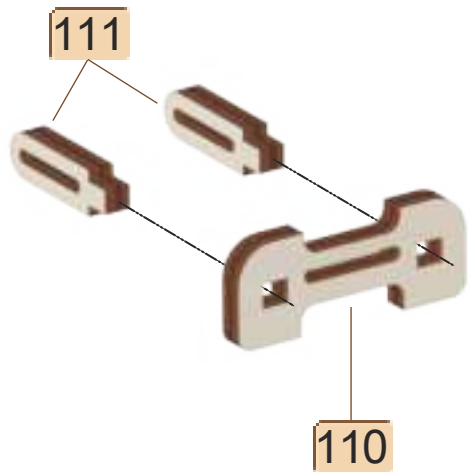

5

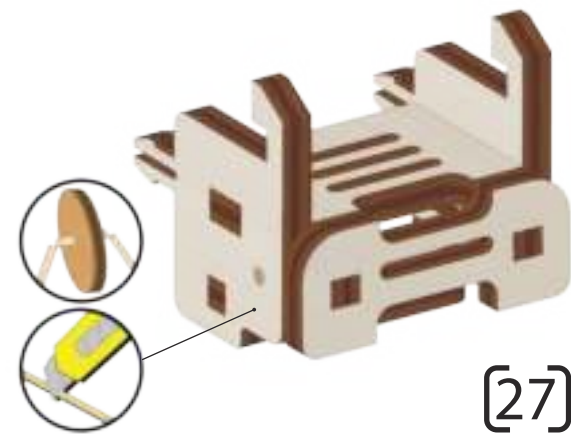
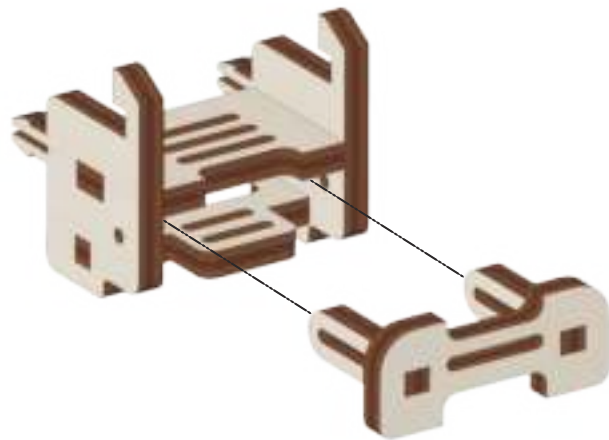

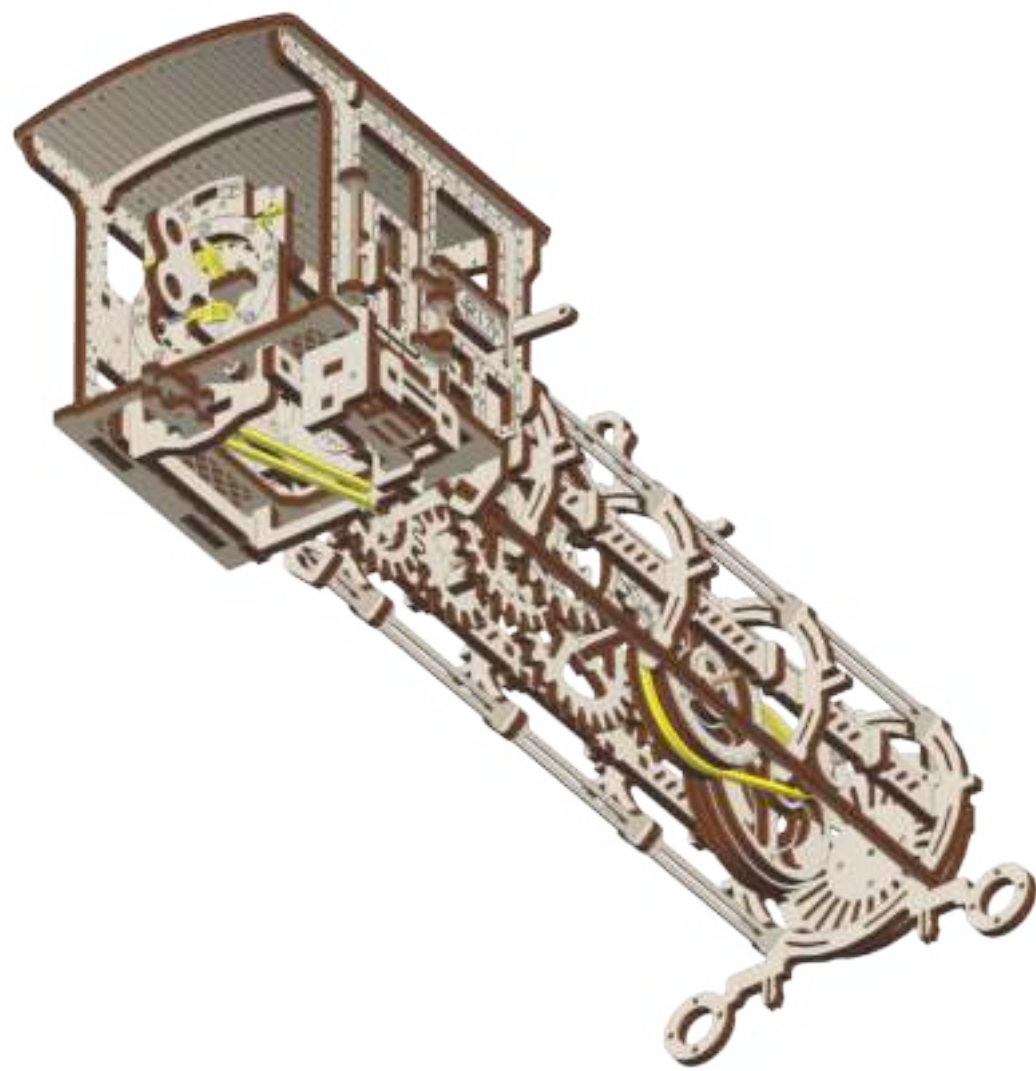
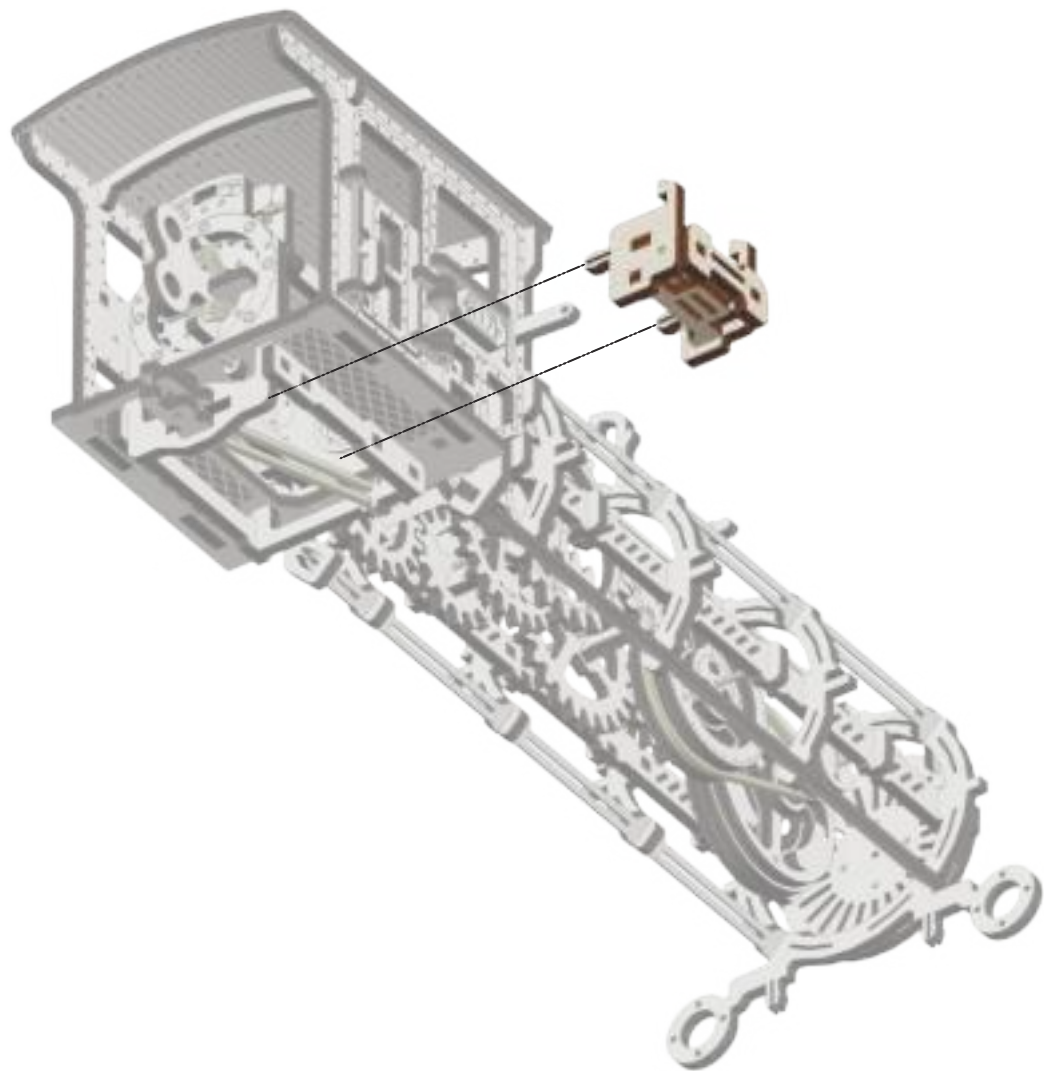

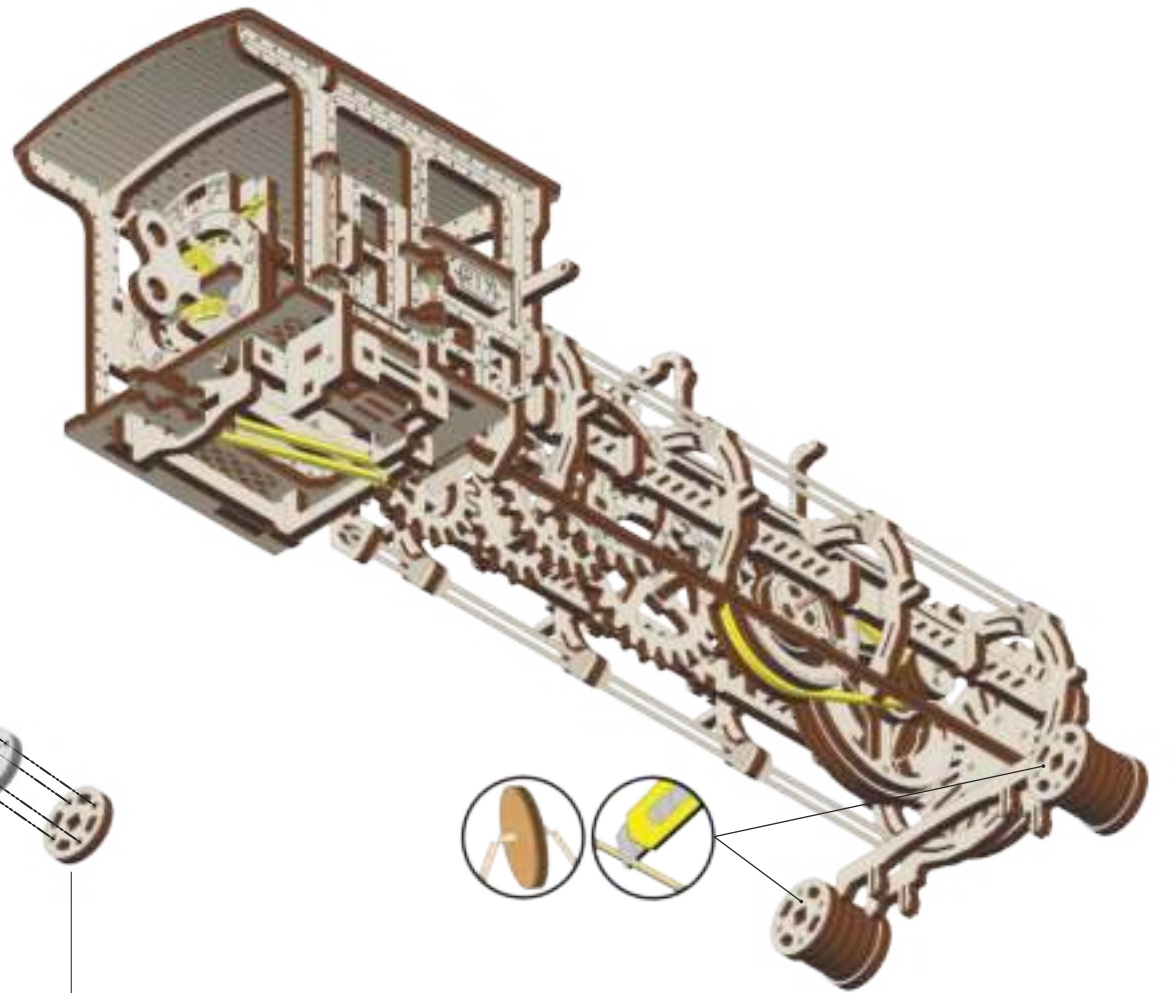
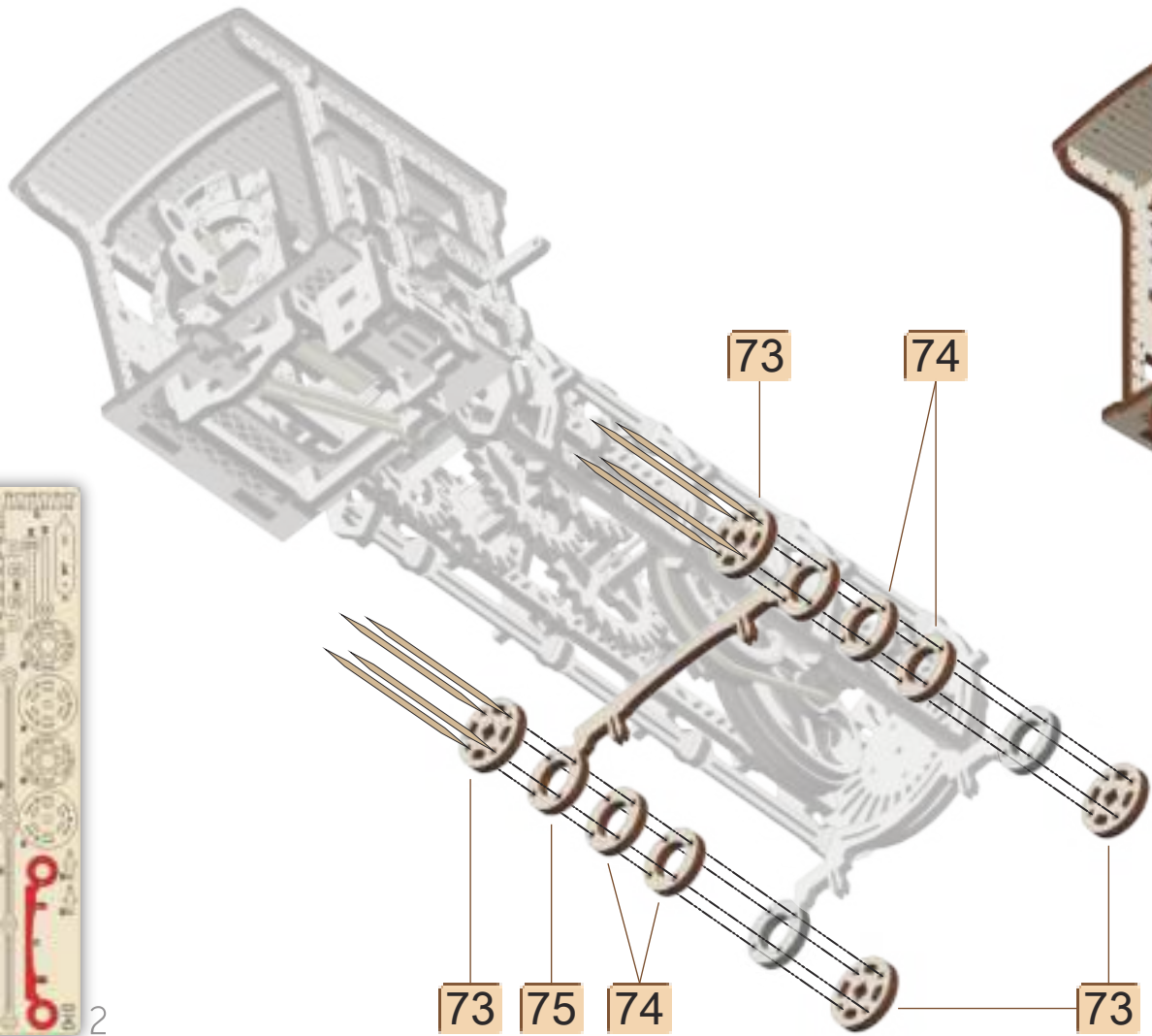



77

76

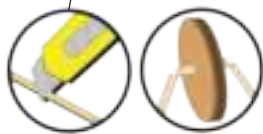
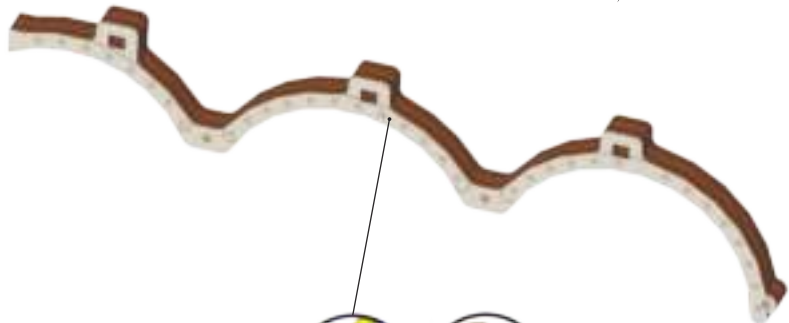
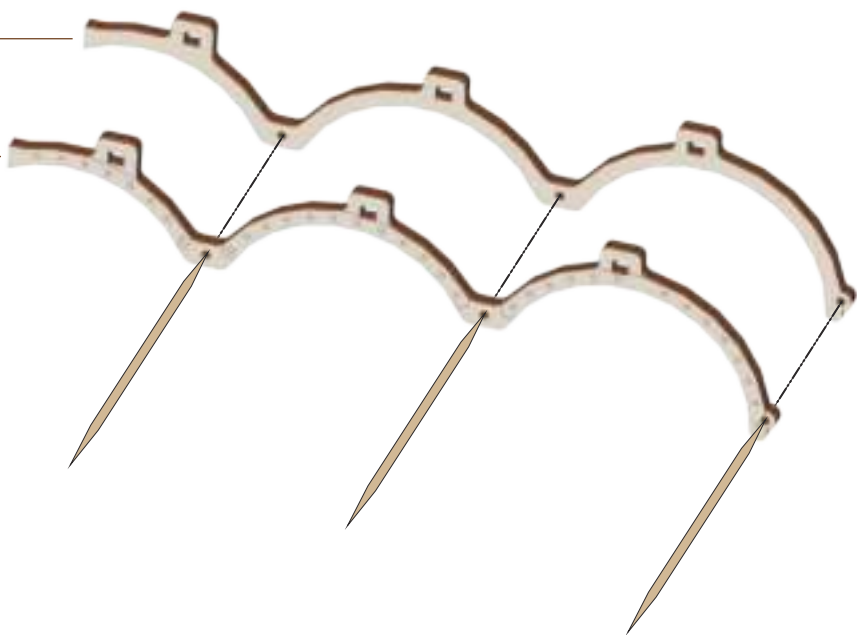

1

77

78

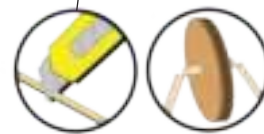
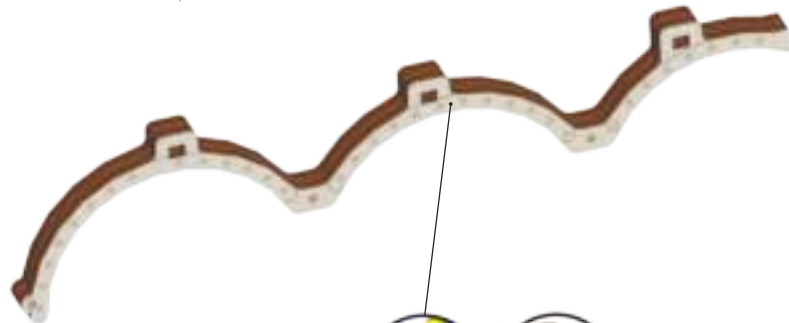
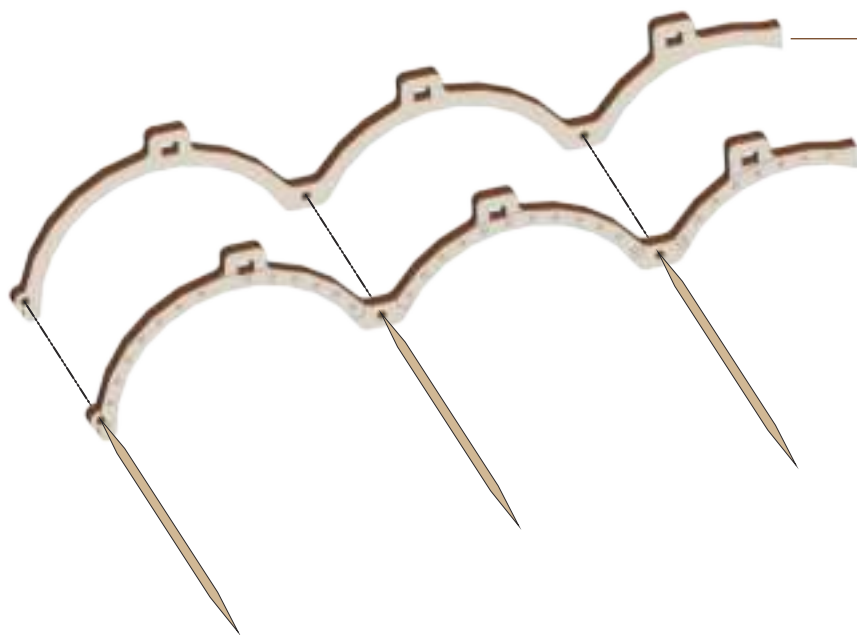

[30]

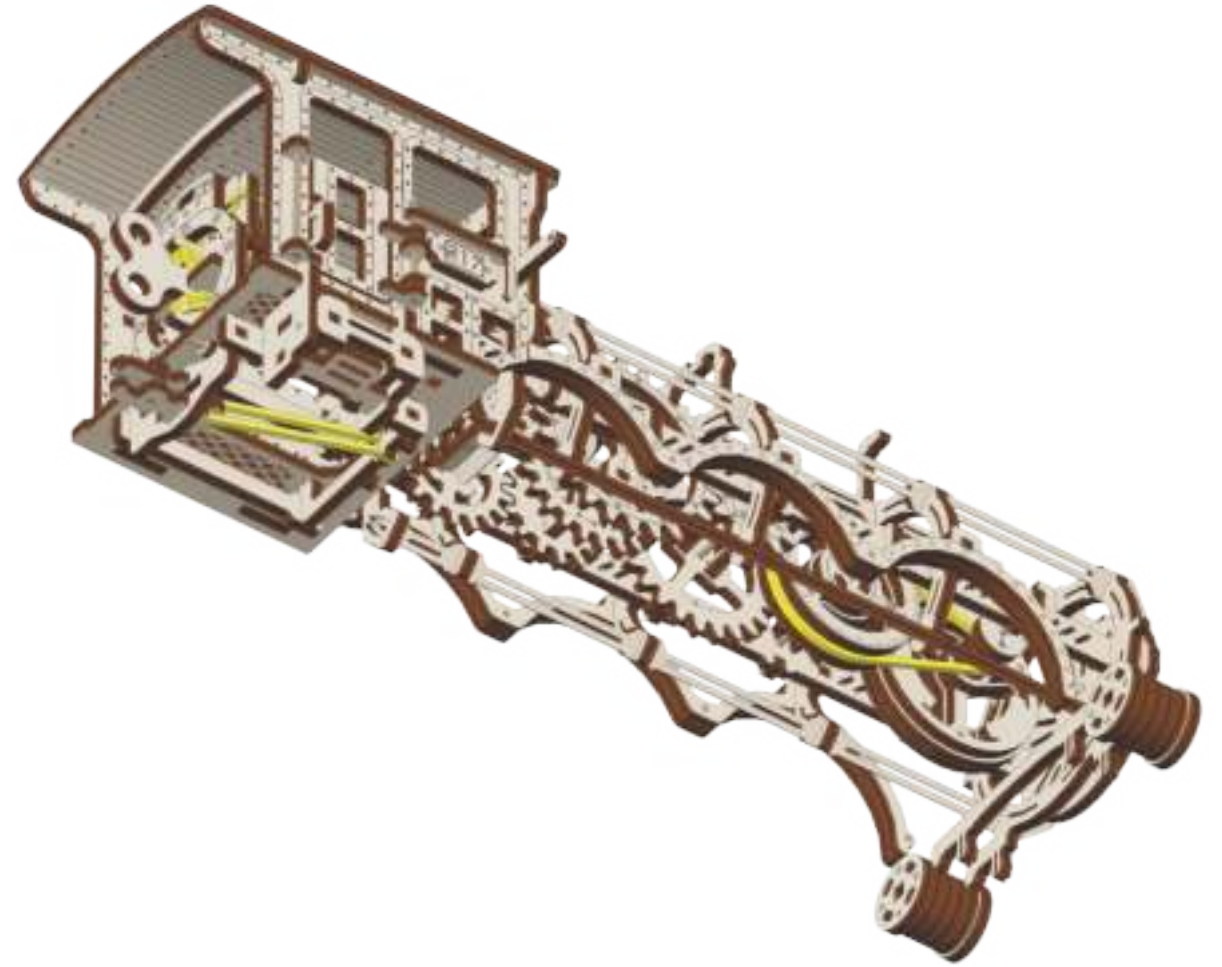
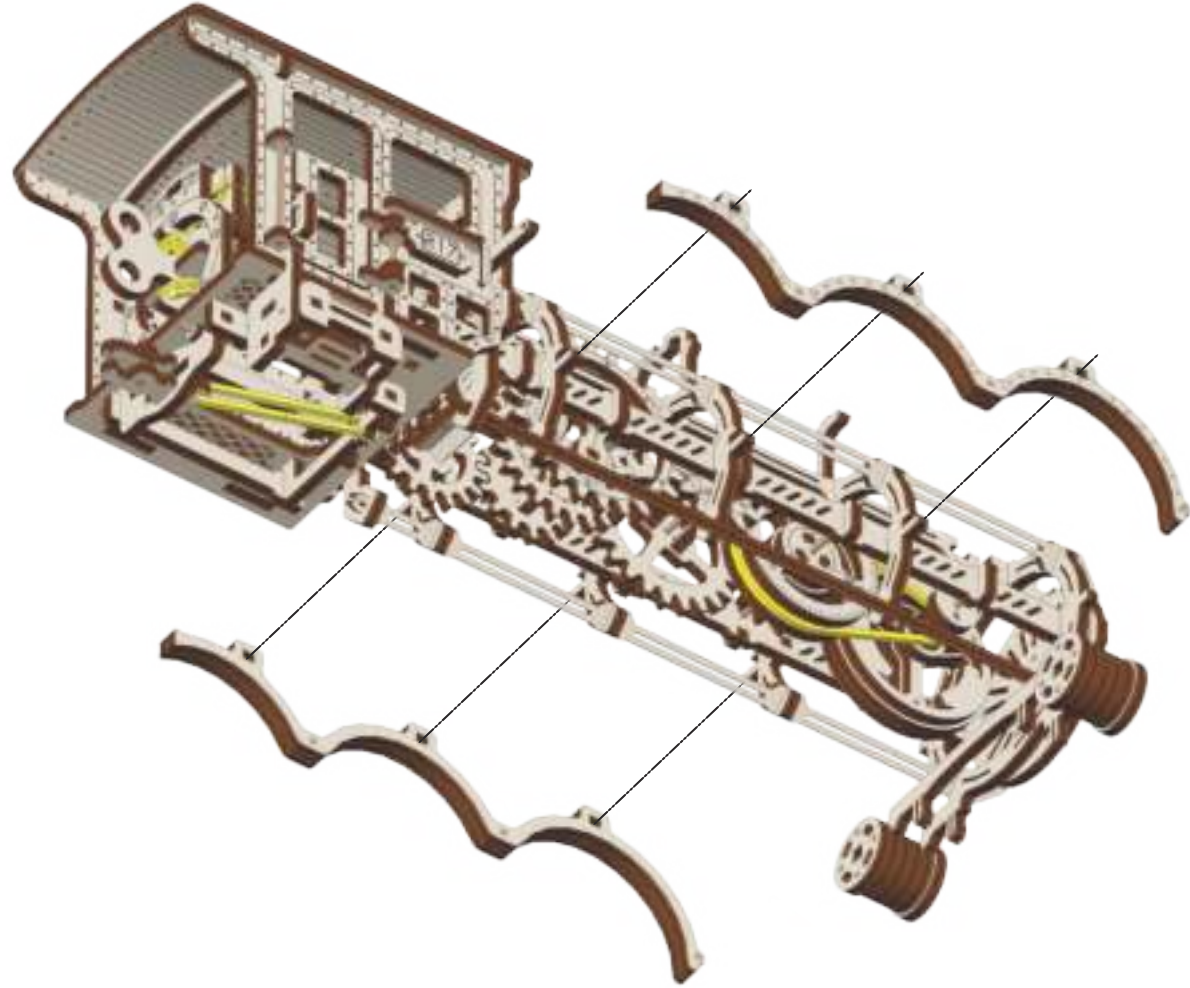



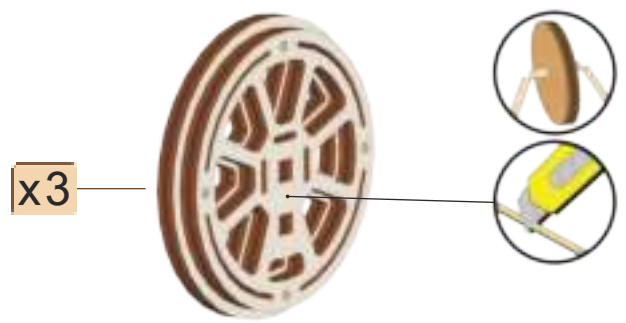
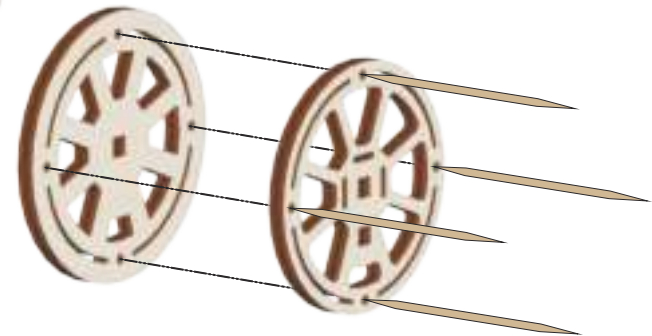
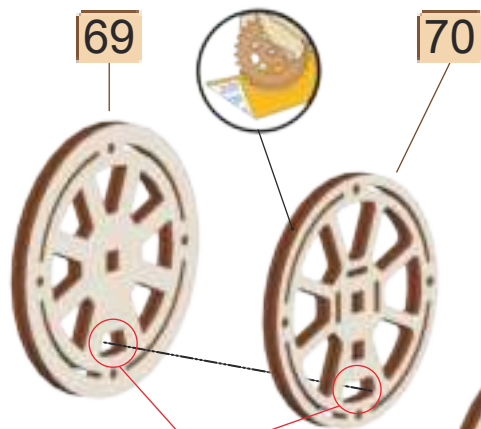
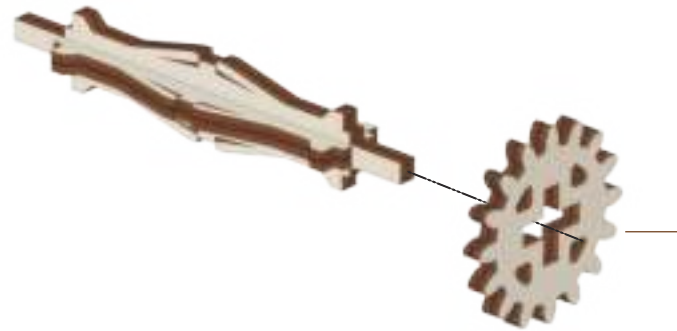
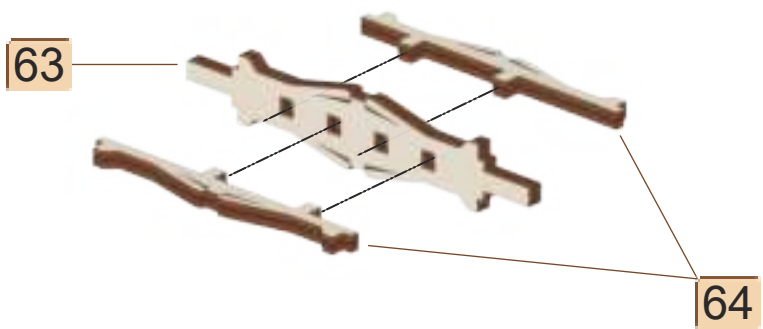
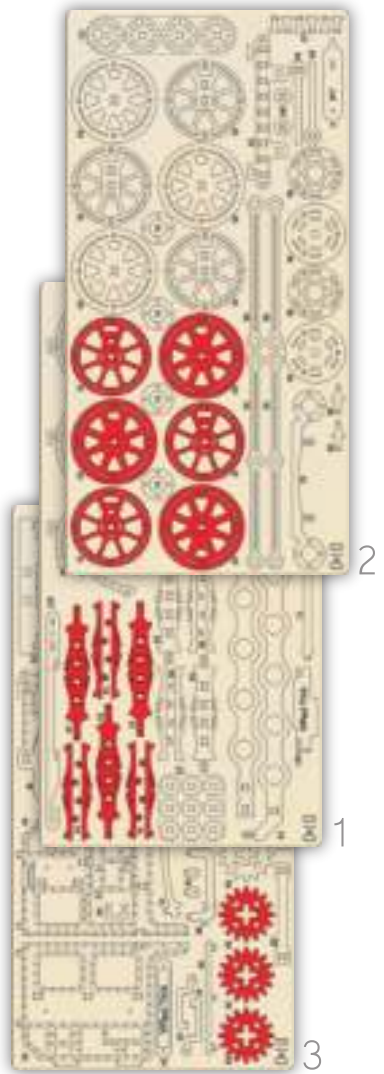

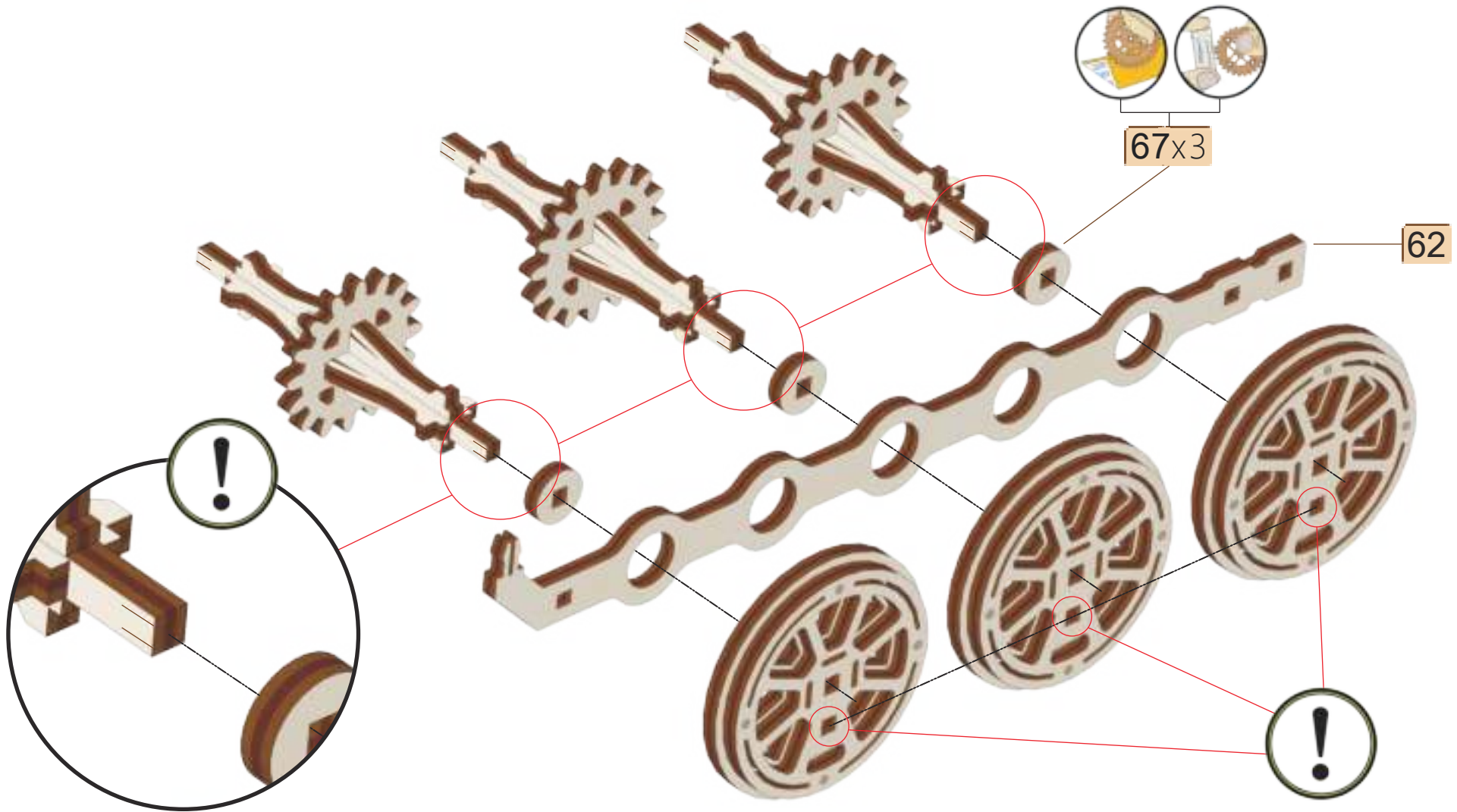
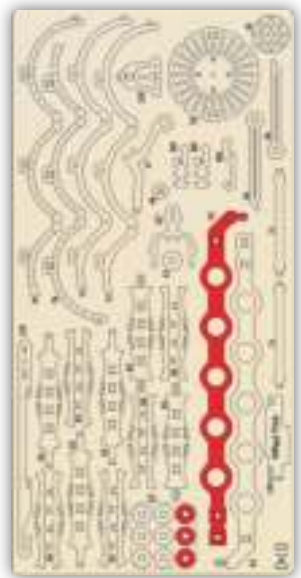



2

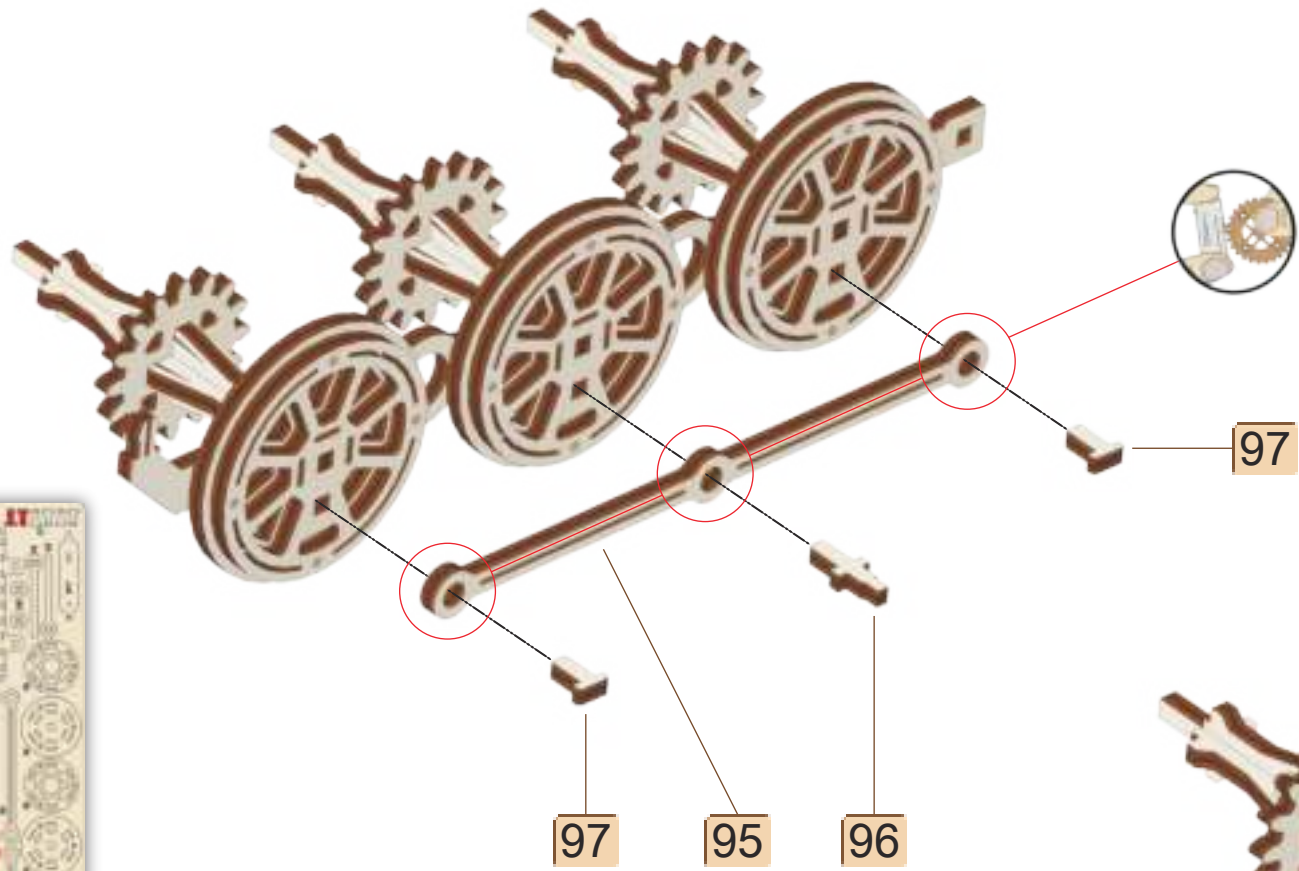

97

97

95

96



[34]

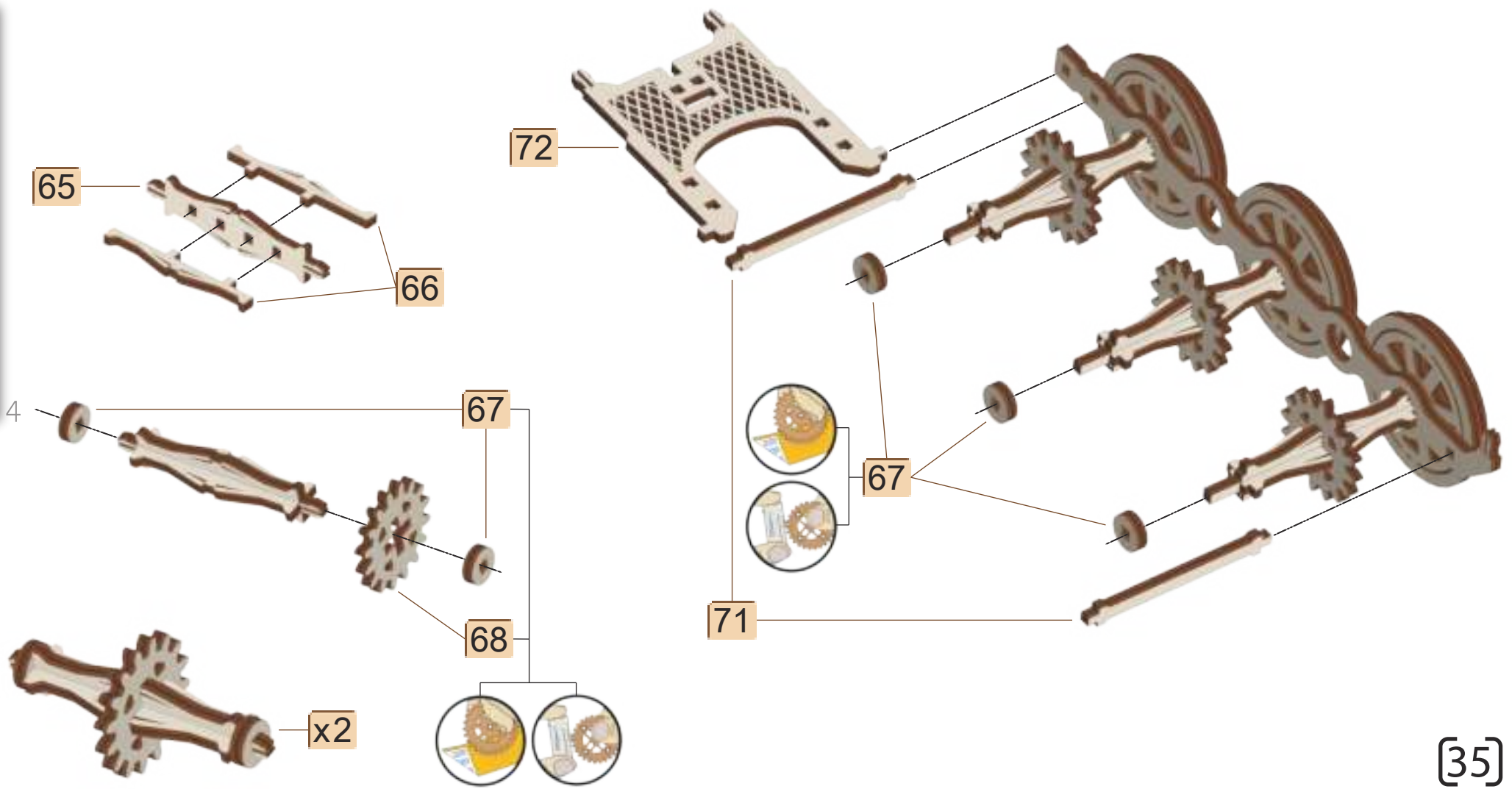

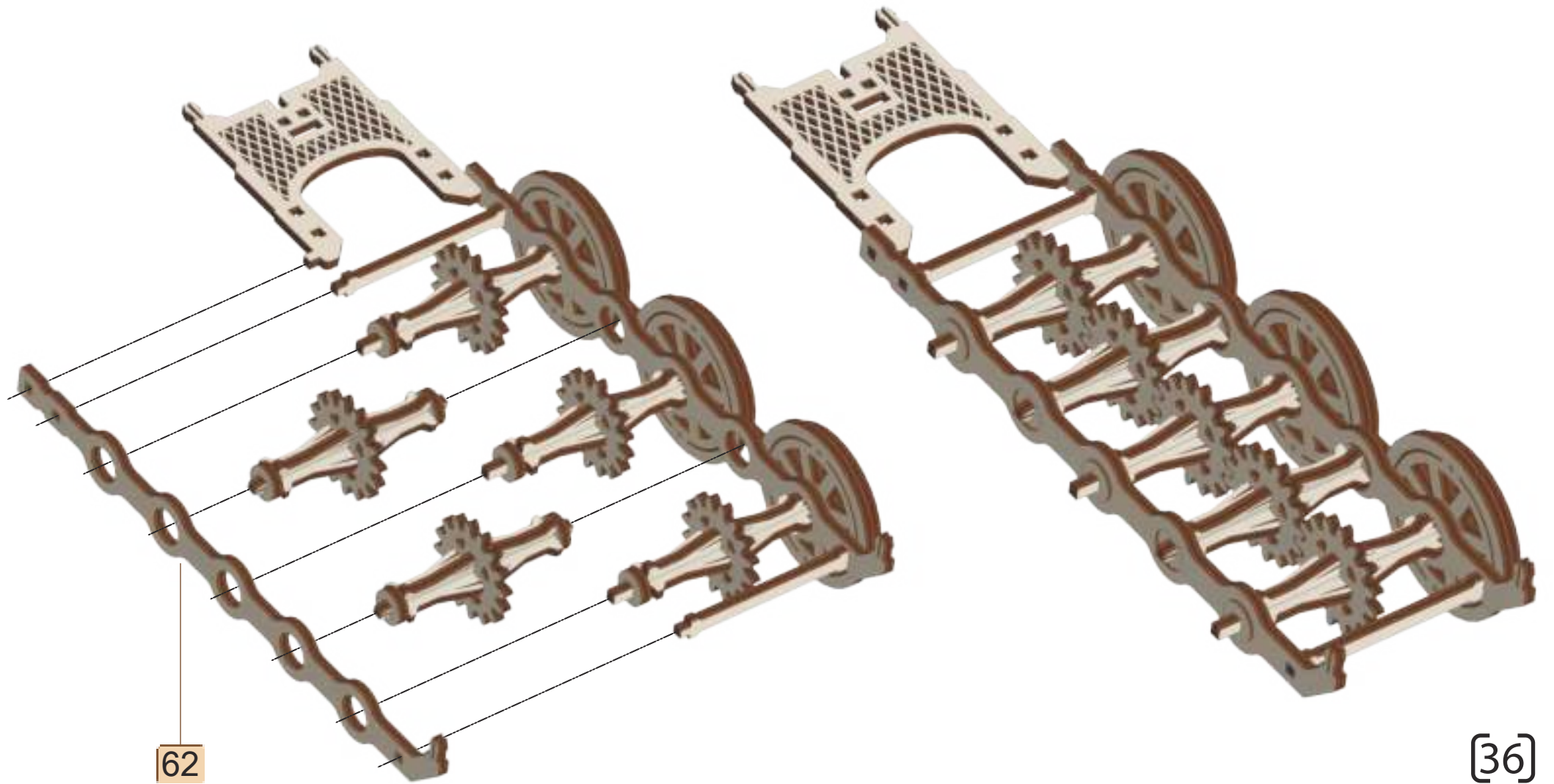
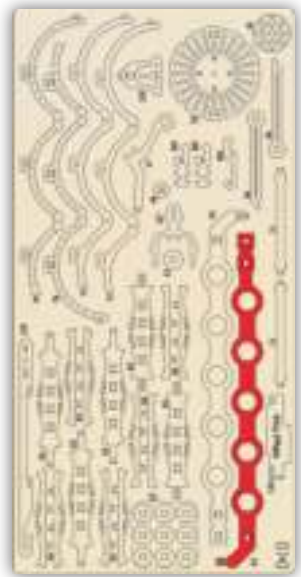

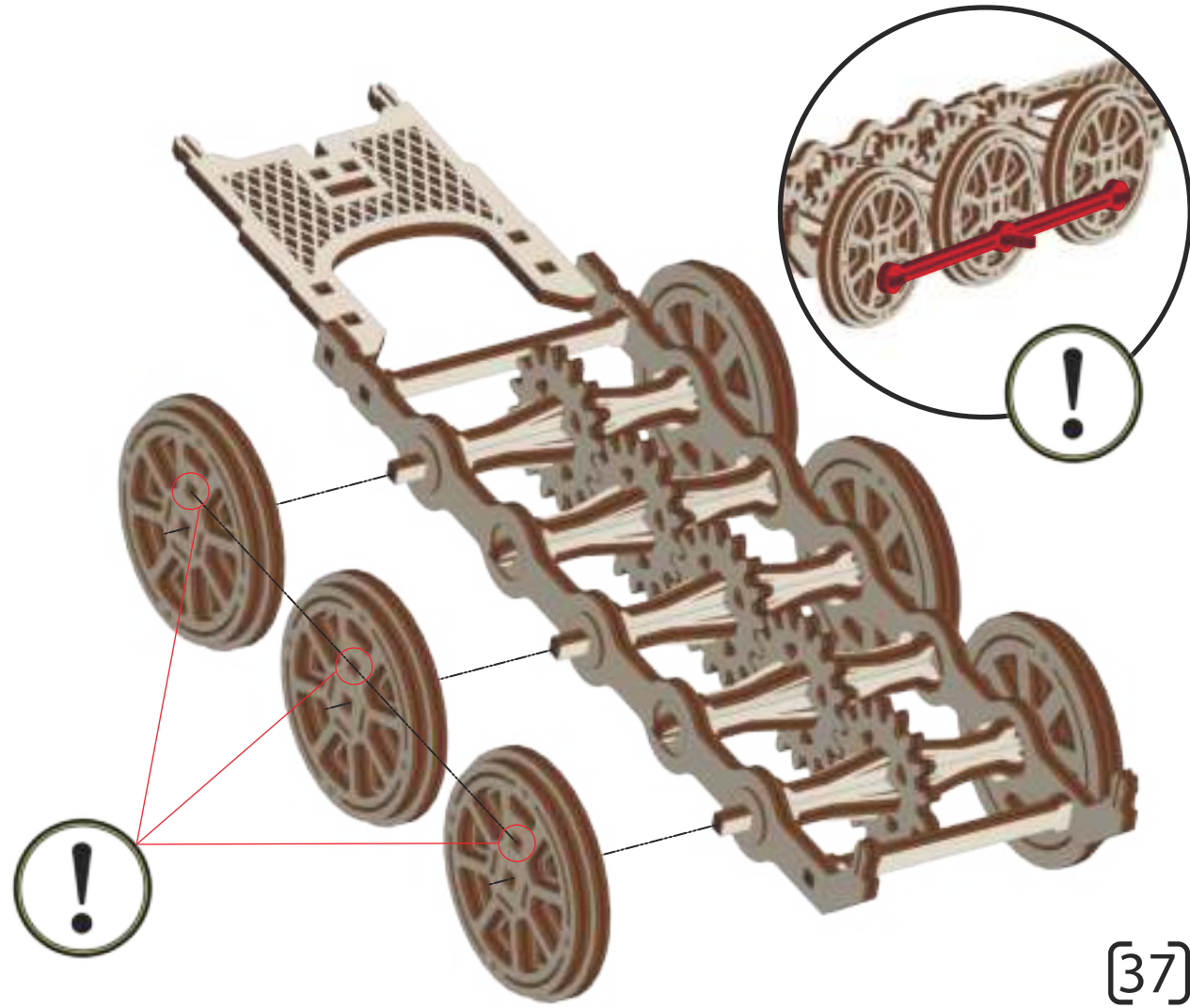
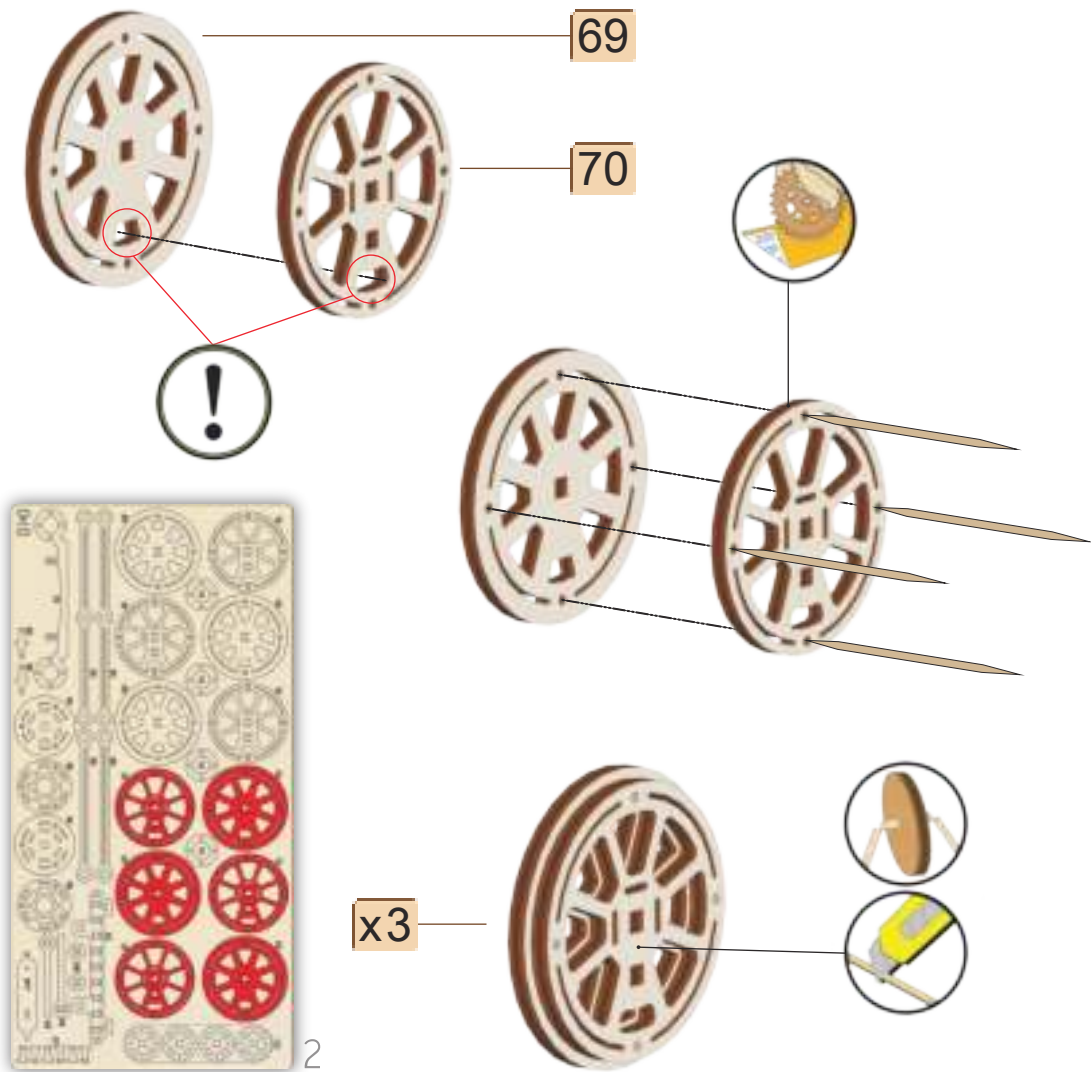



2

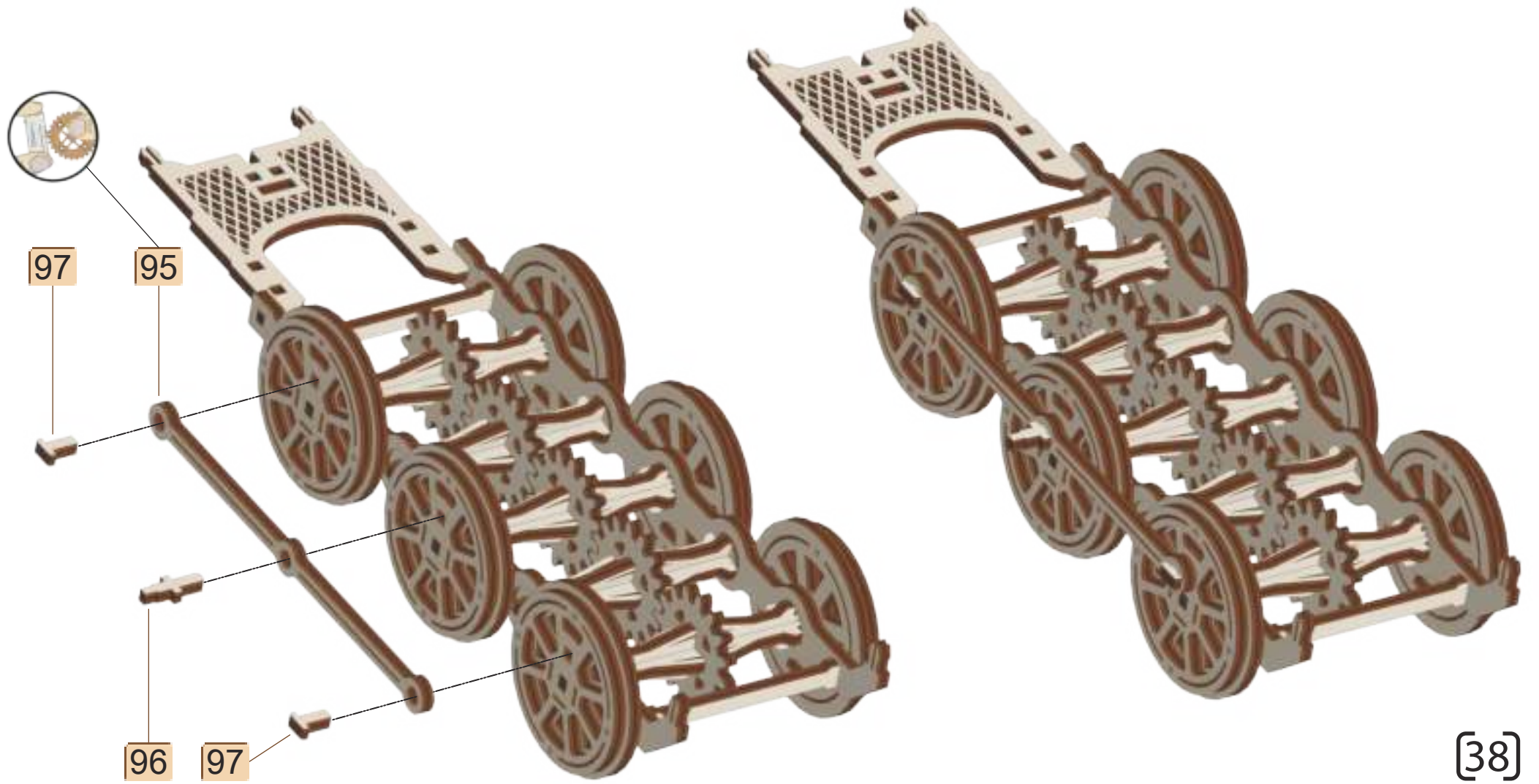

79



4

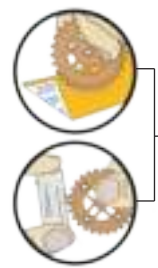
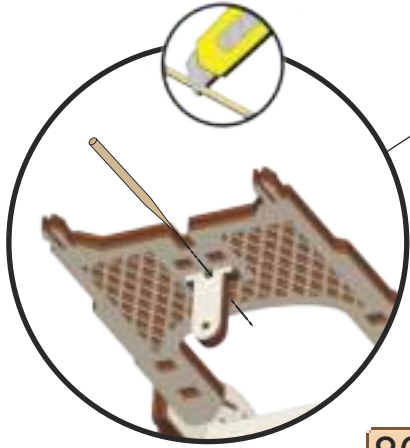

80

81

80

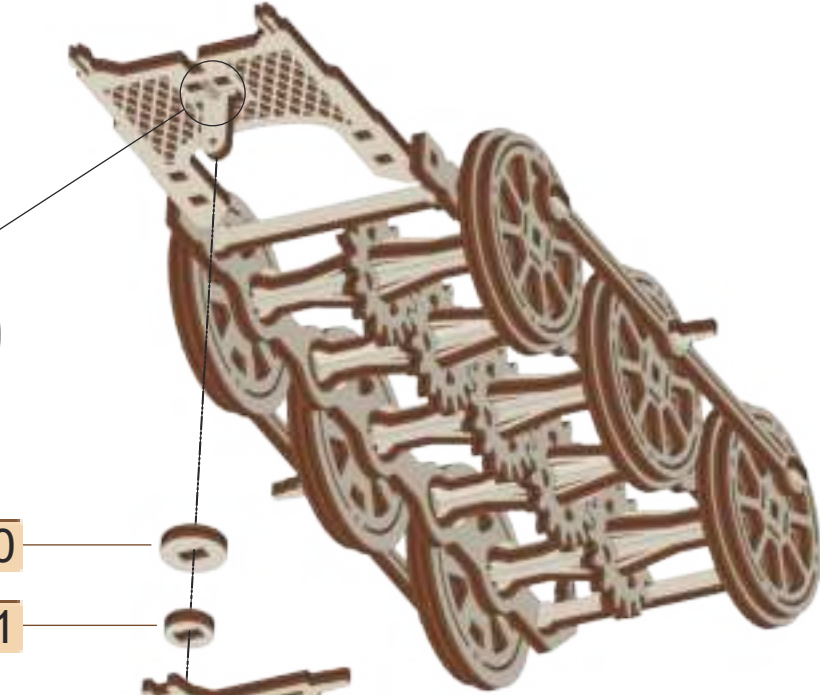

82

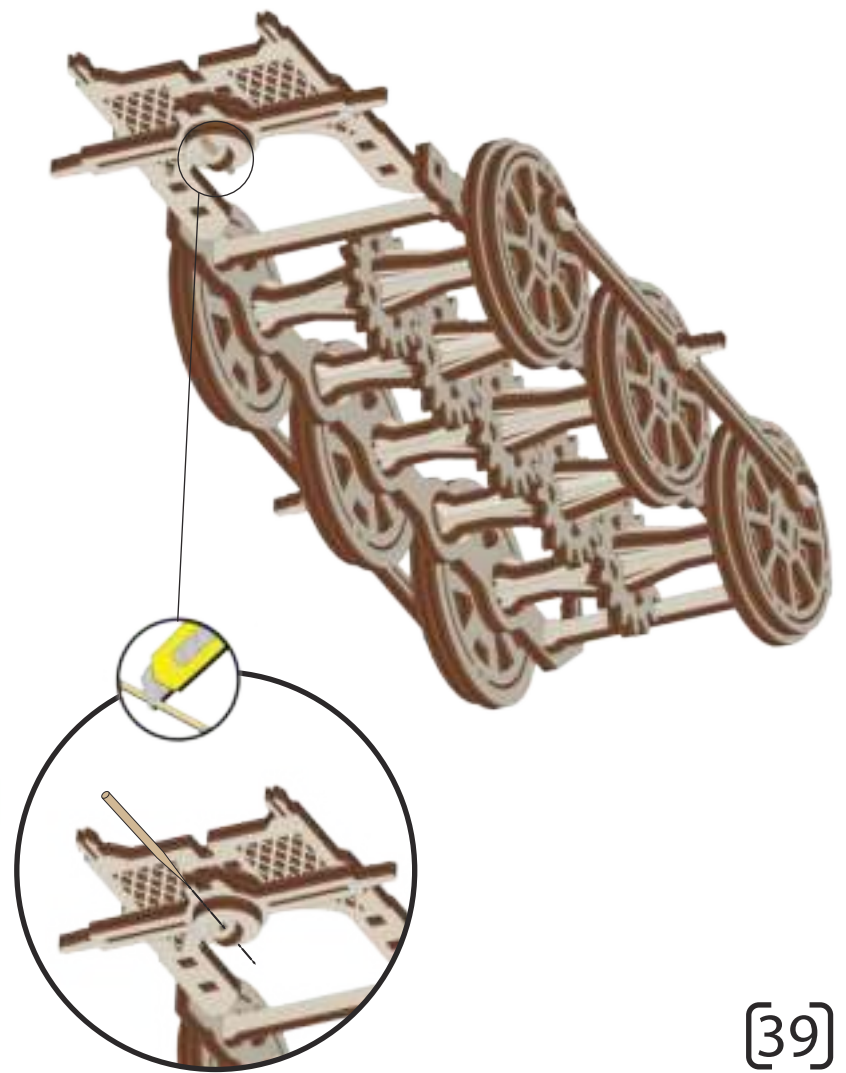

[39]



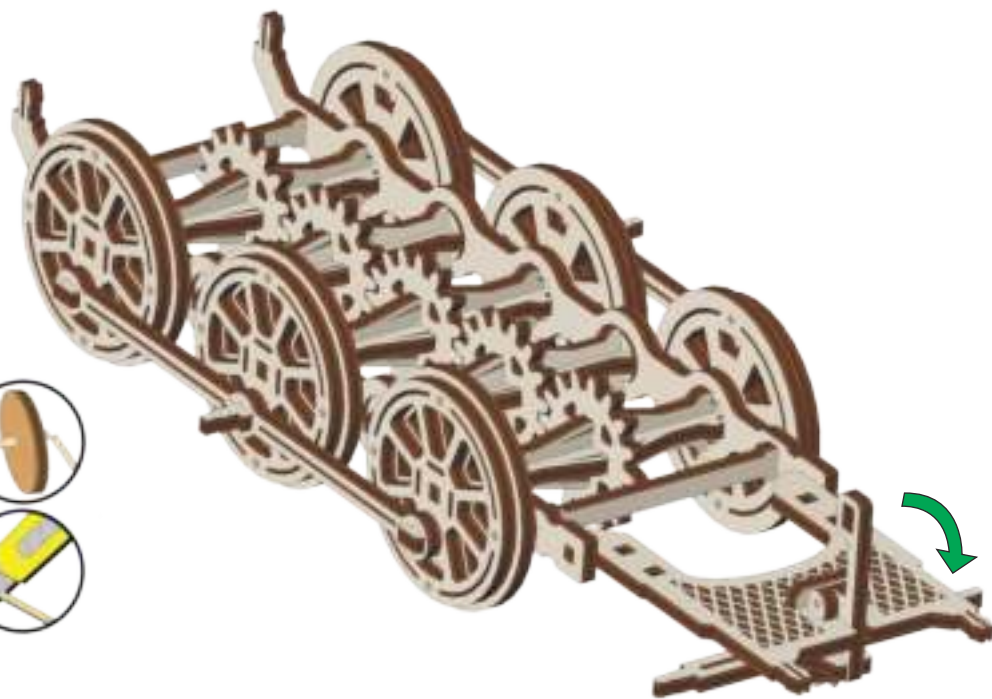
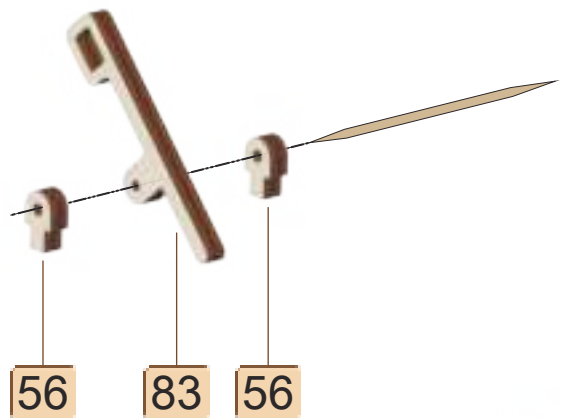

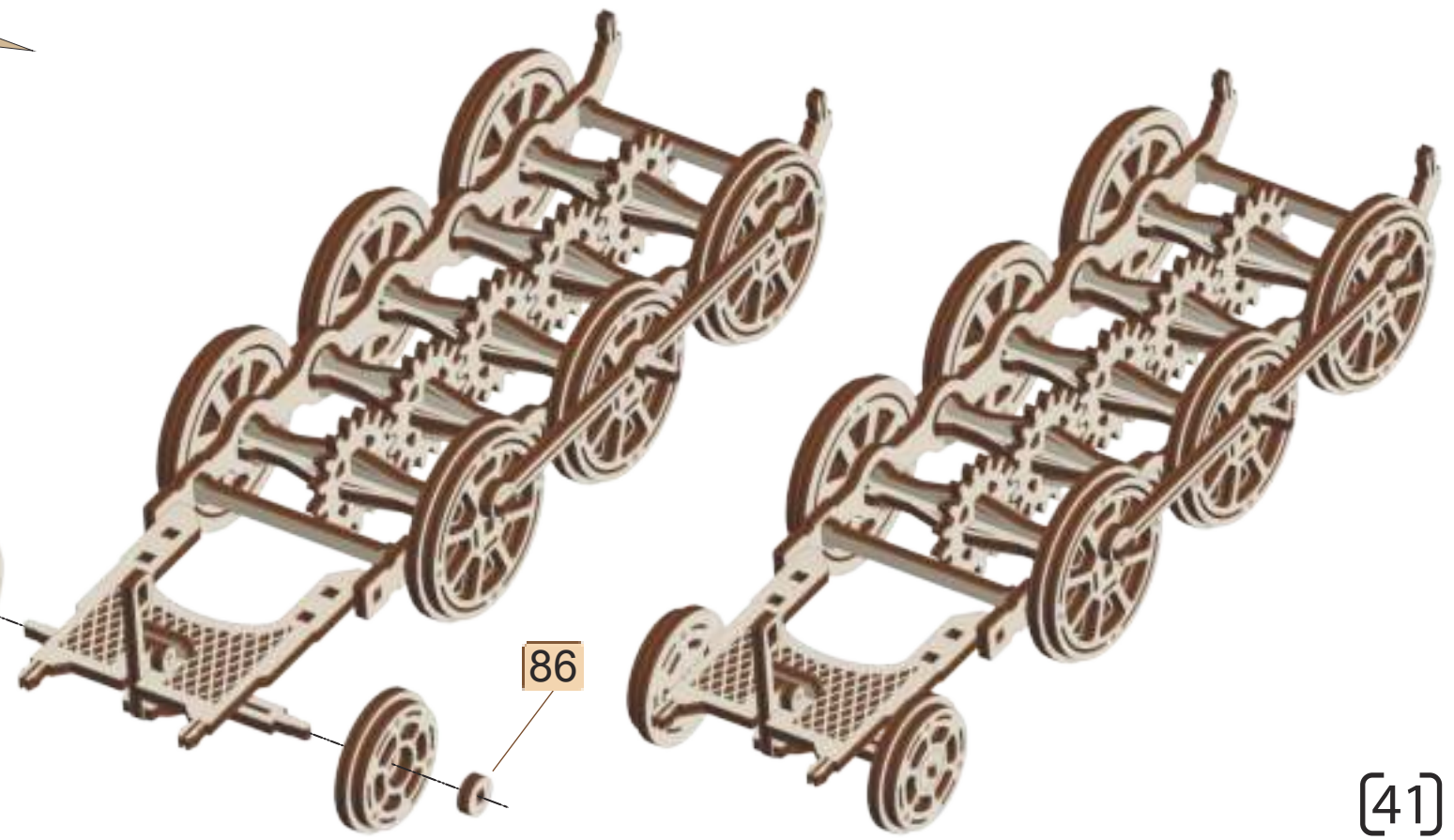
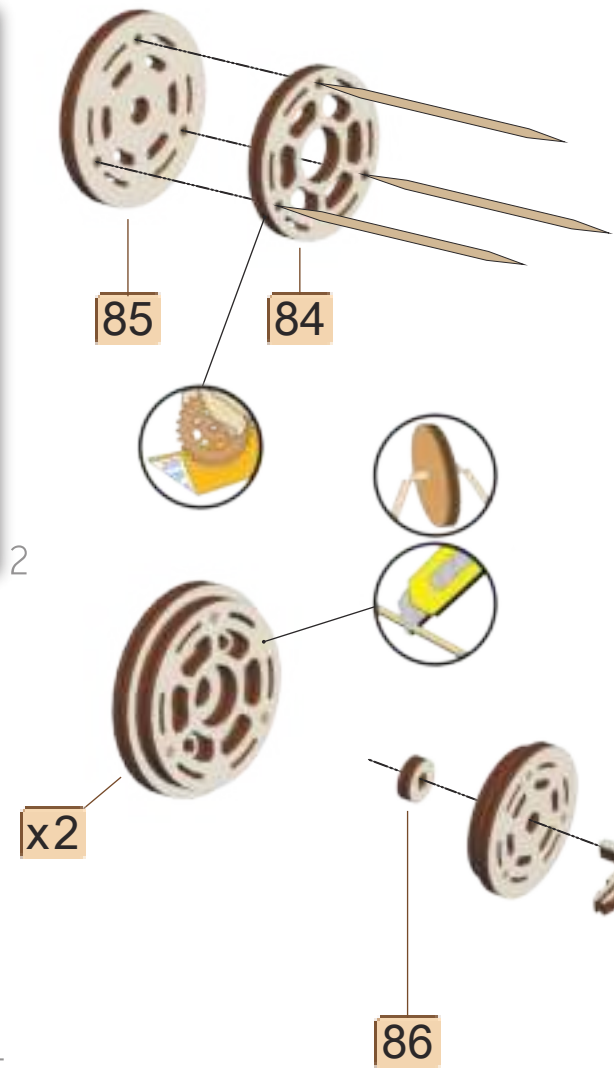

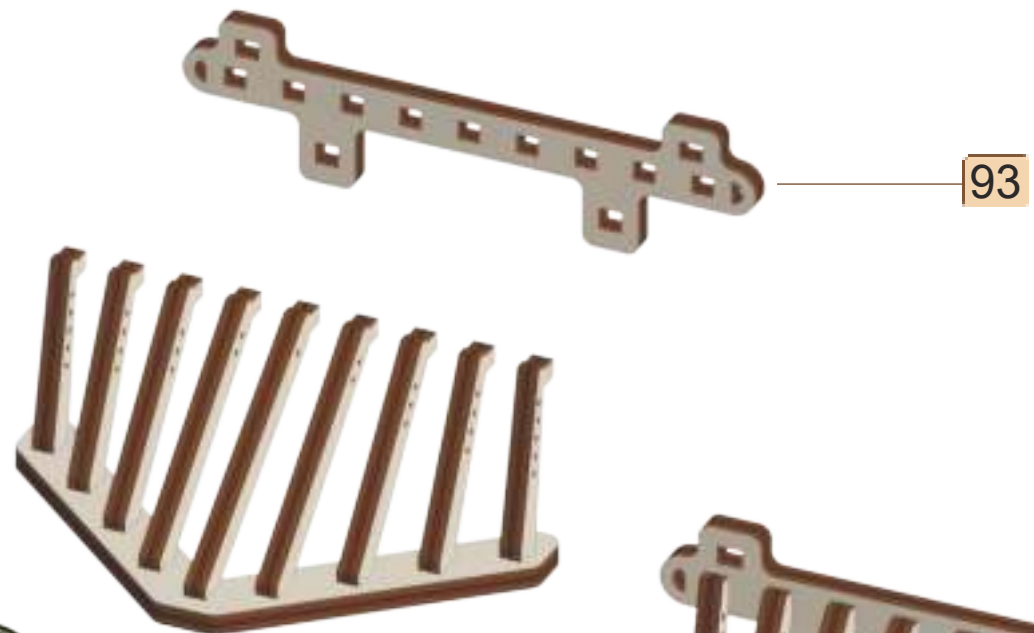
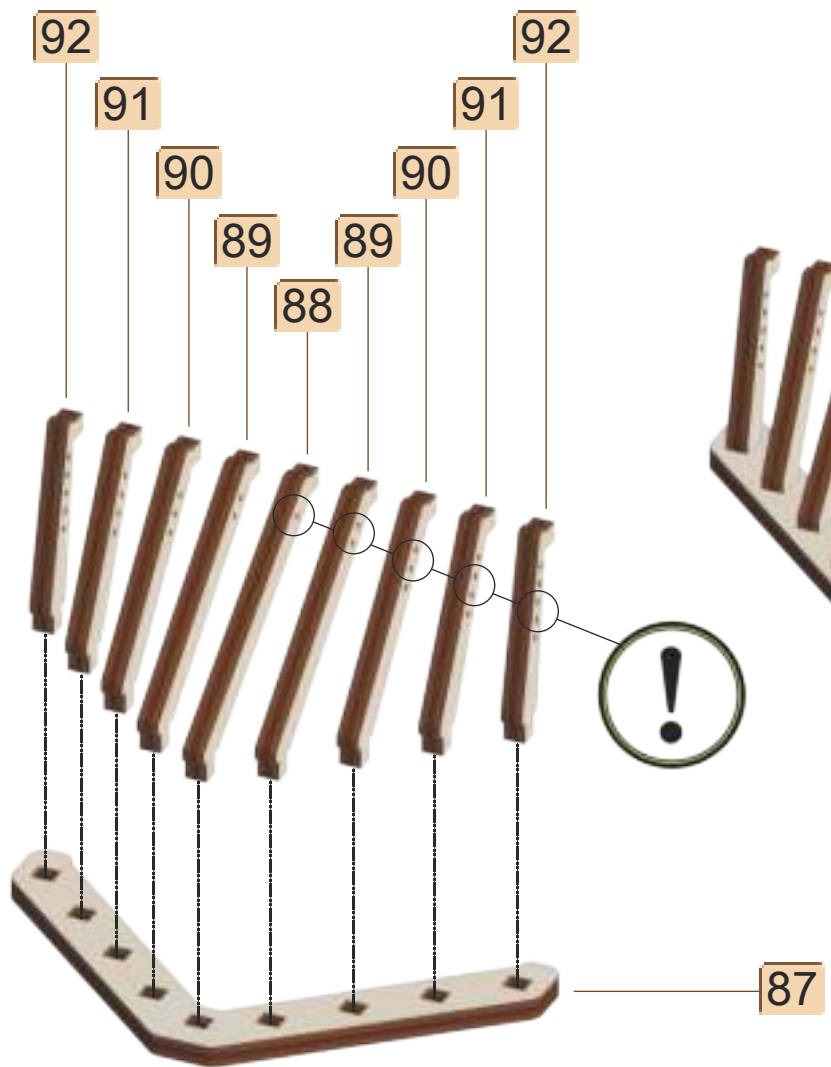



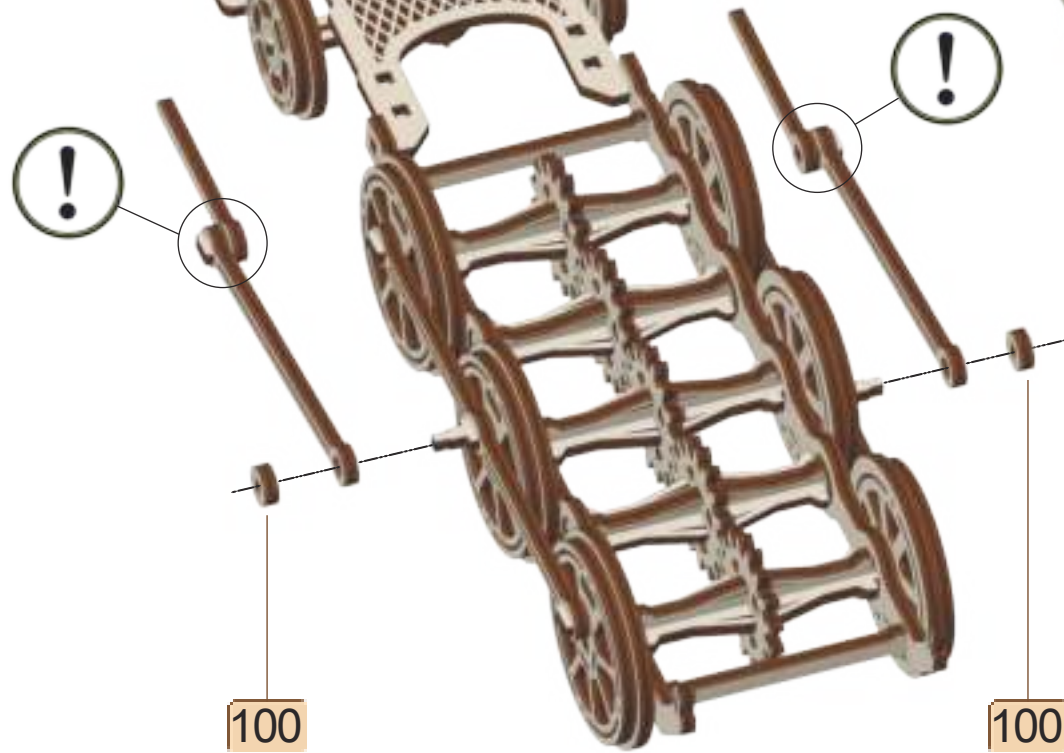
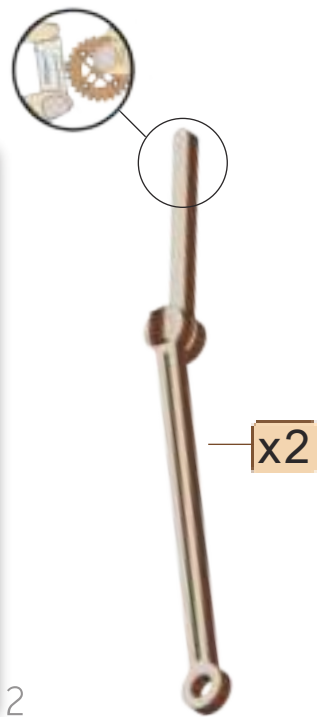

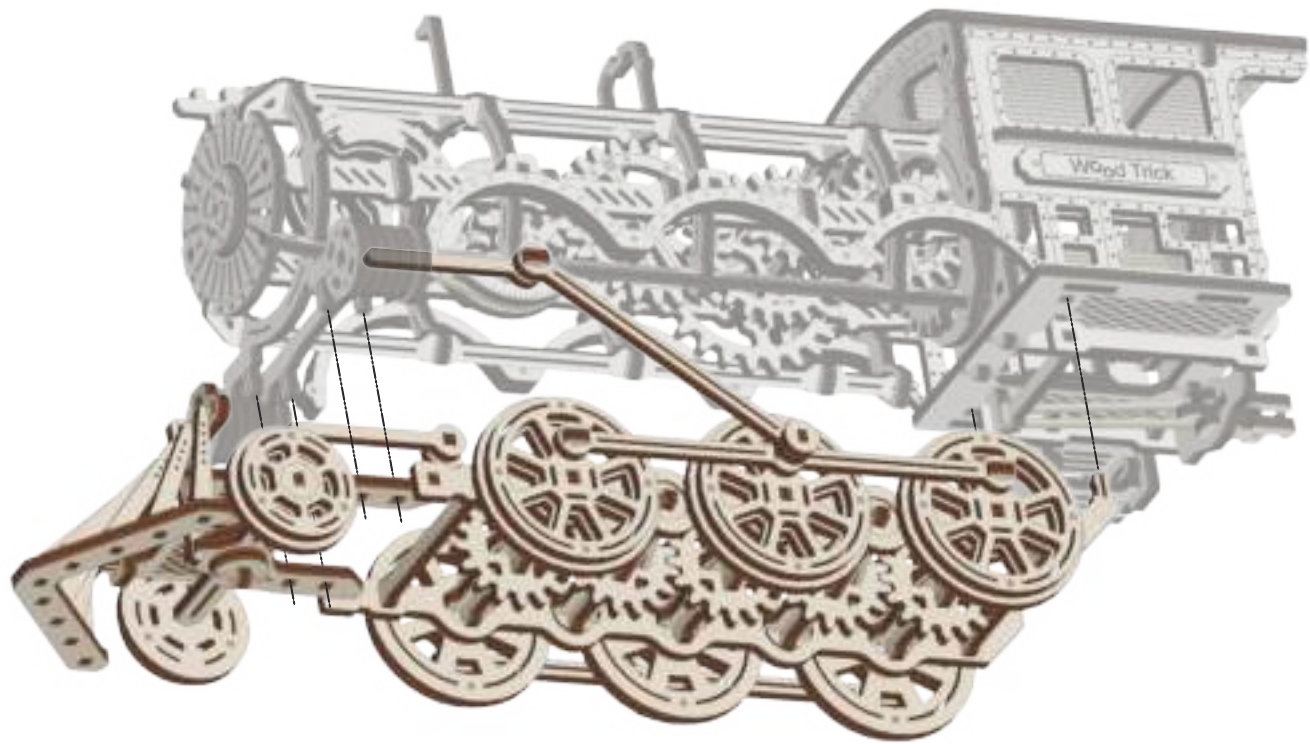
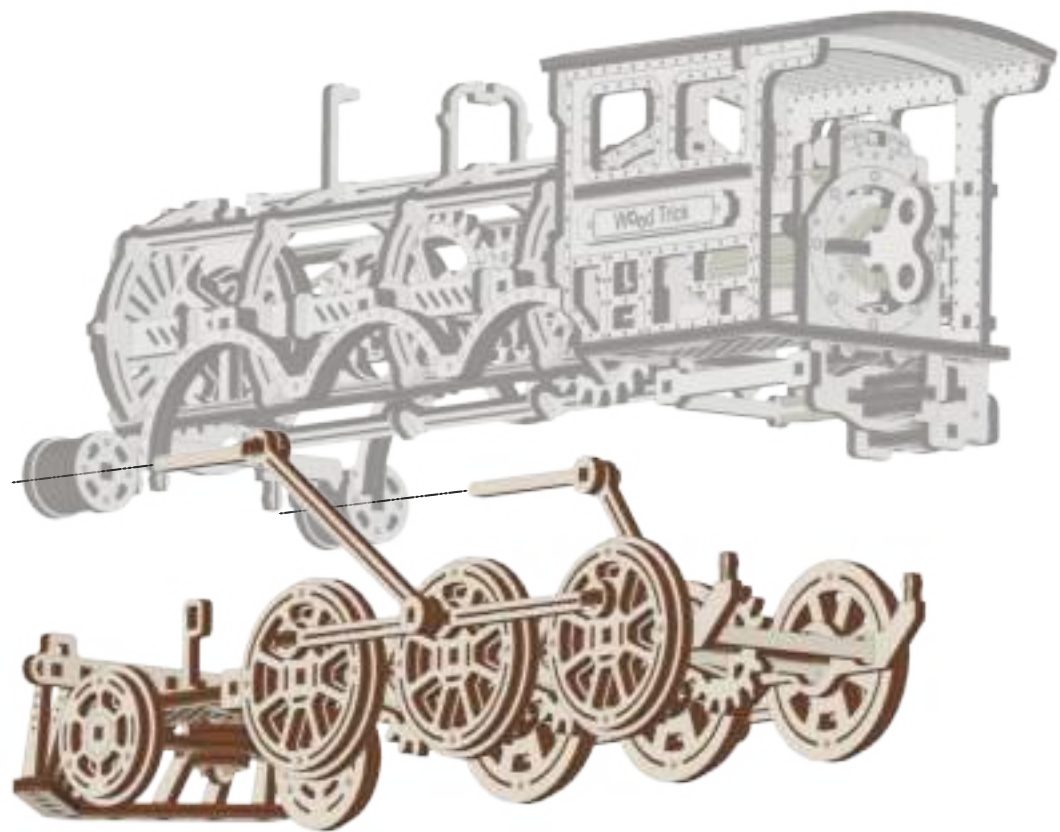

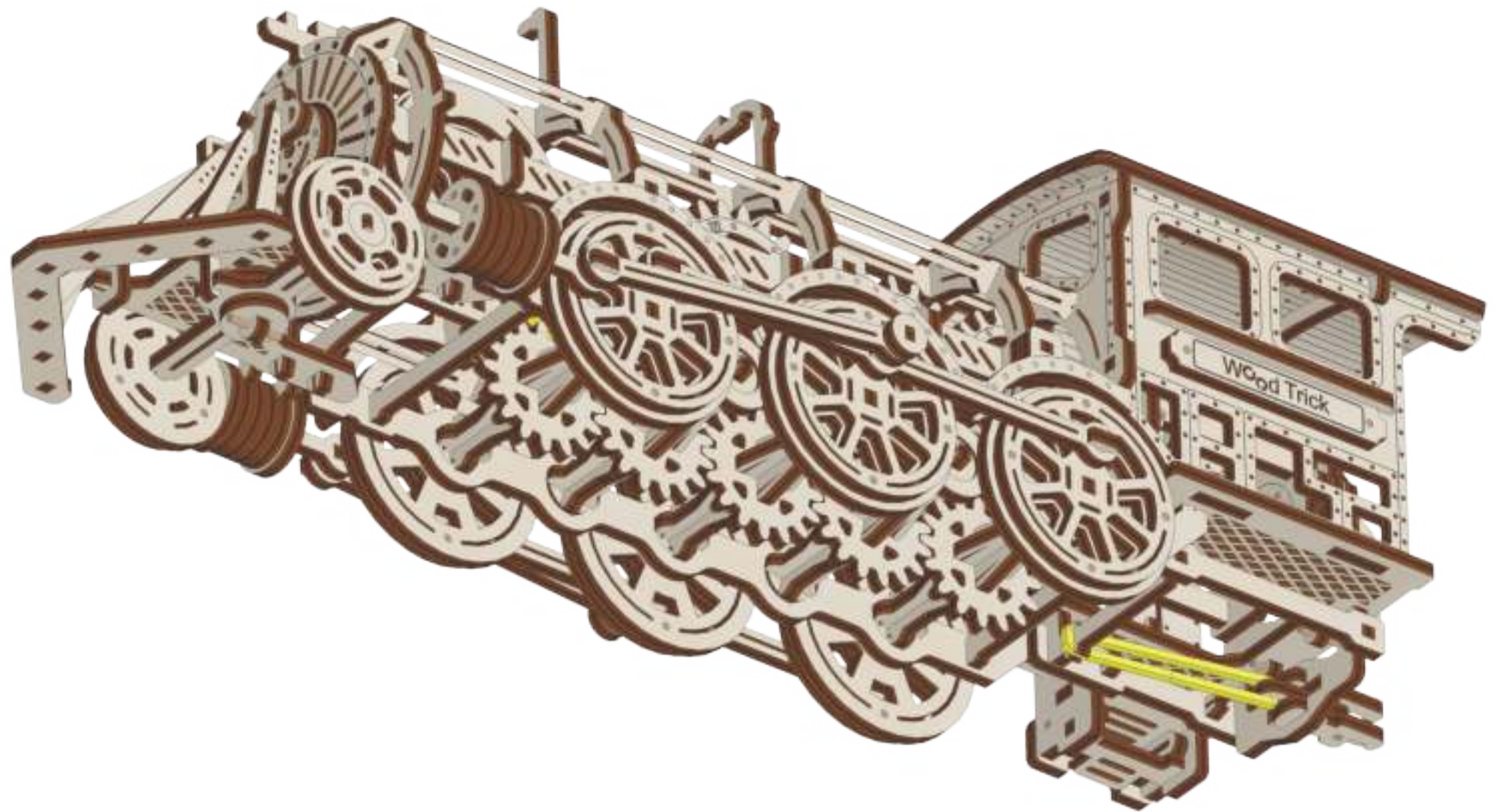

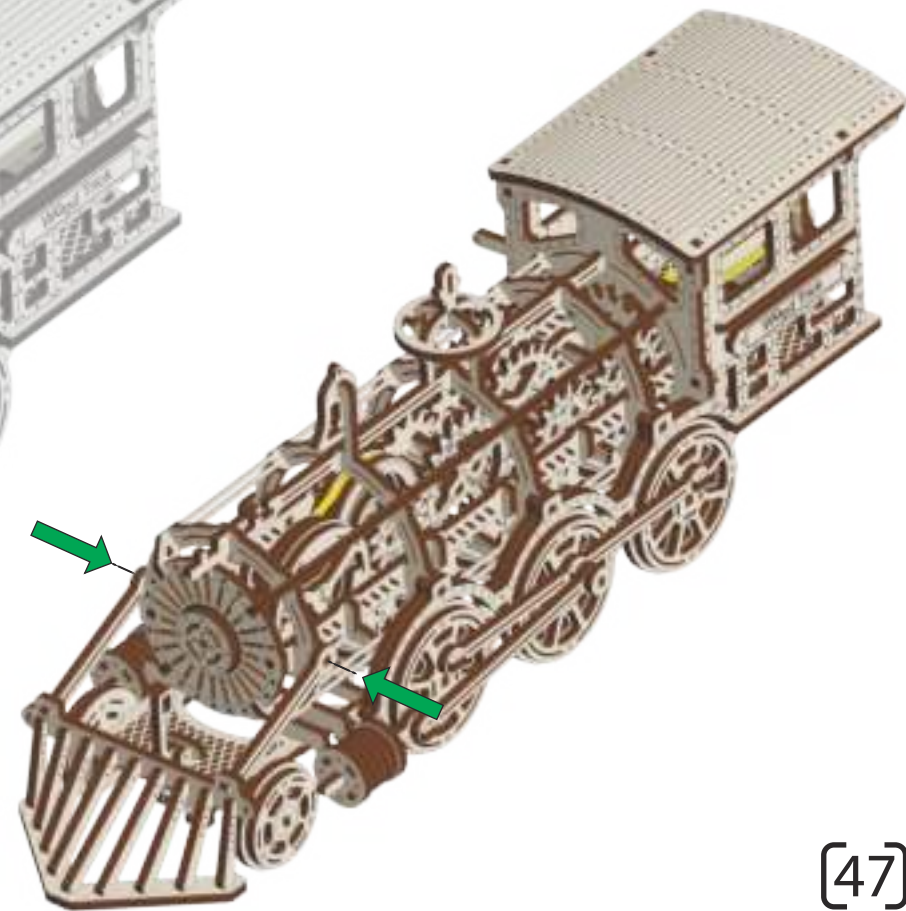
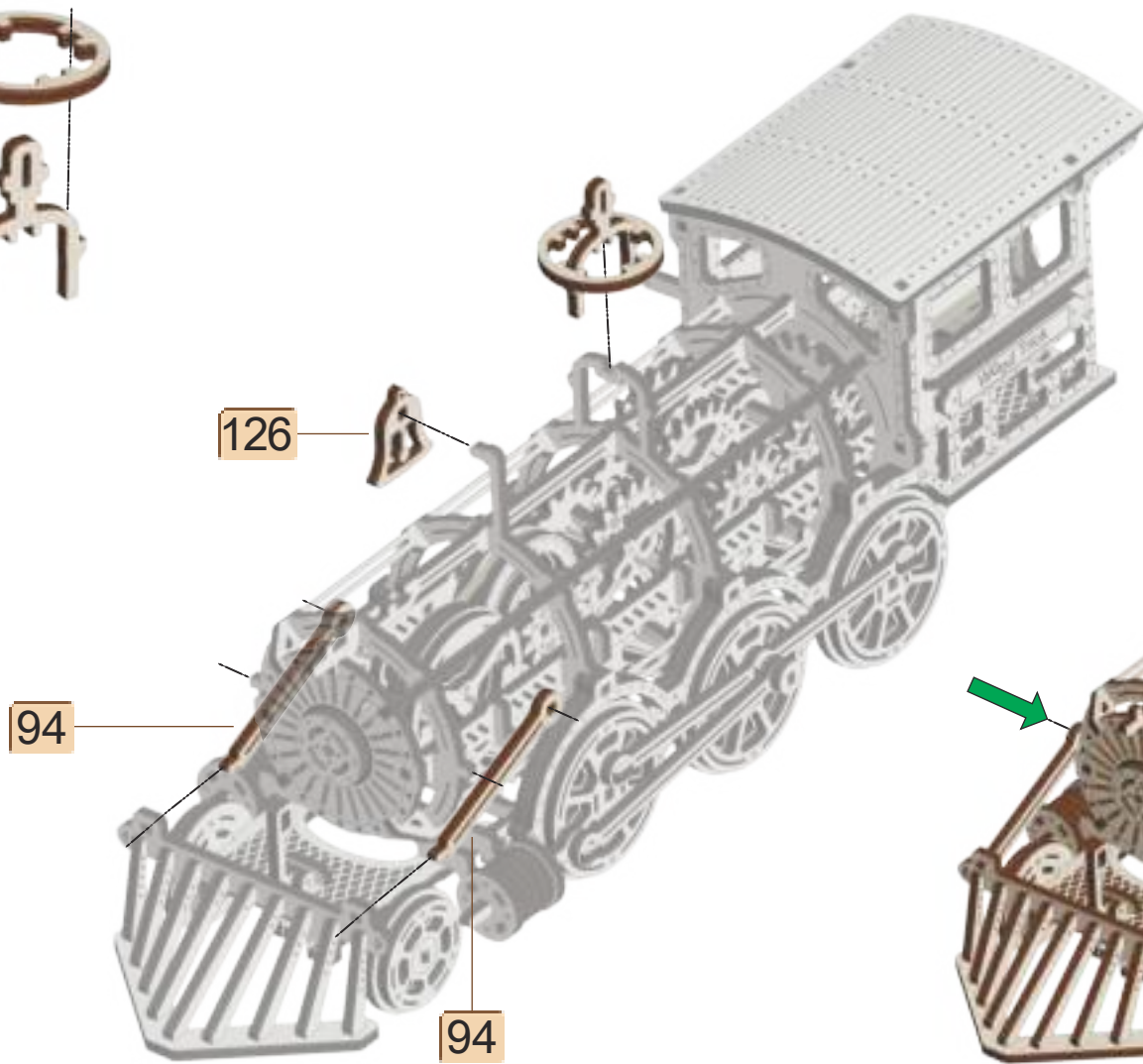
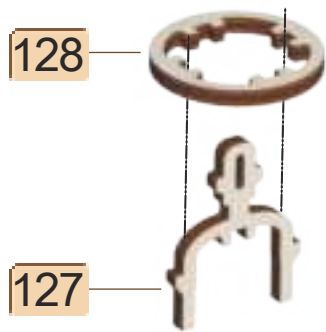
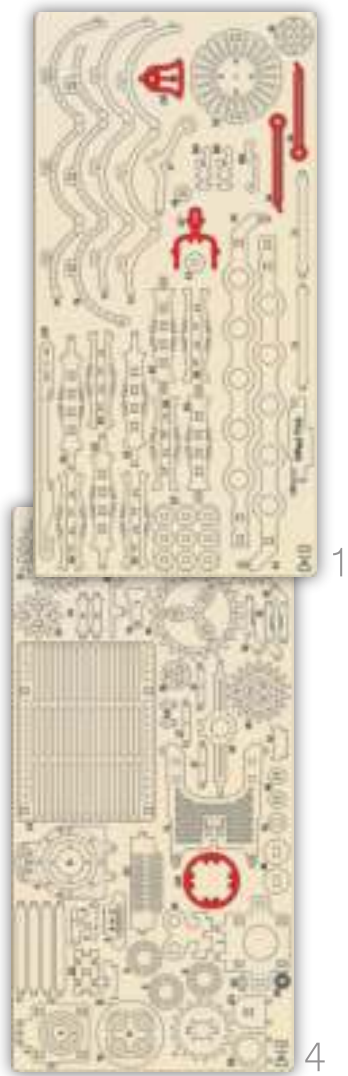





5

4



119

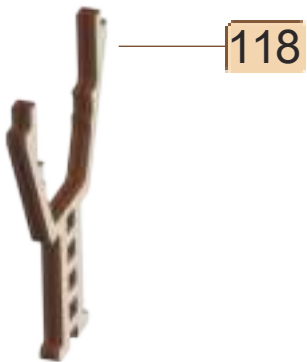

118

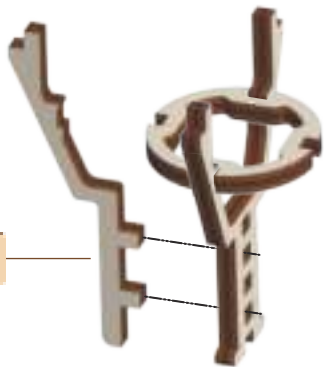

120

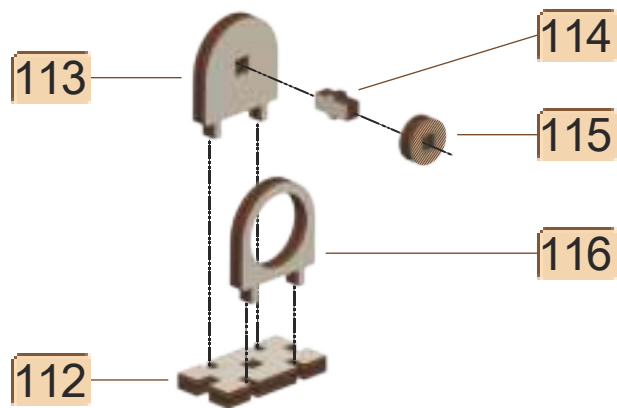

113

114

115

116

112

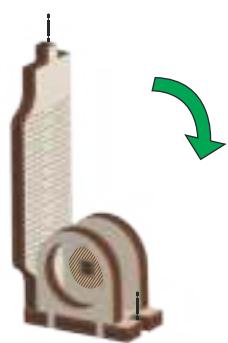

117

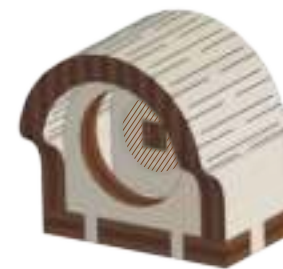

[48]



5

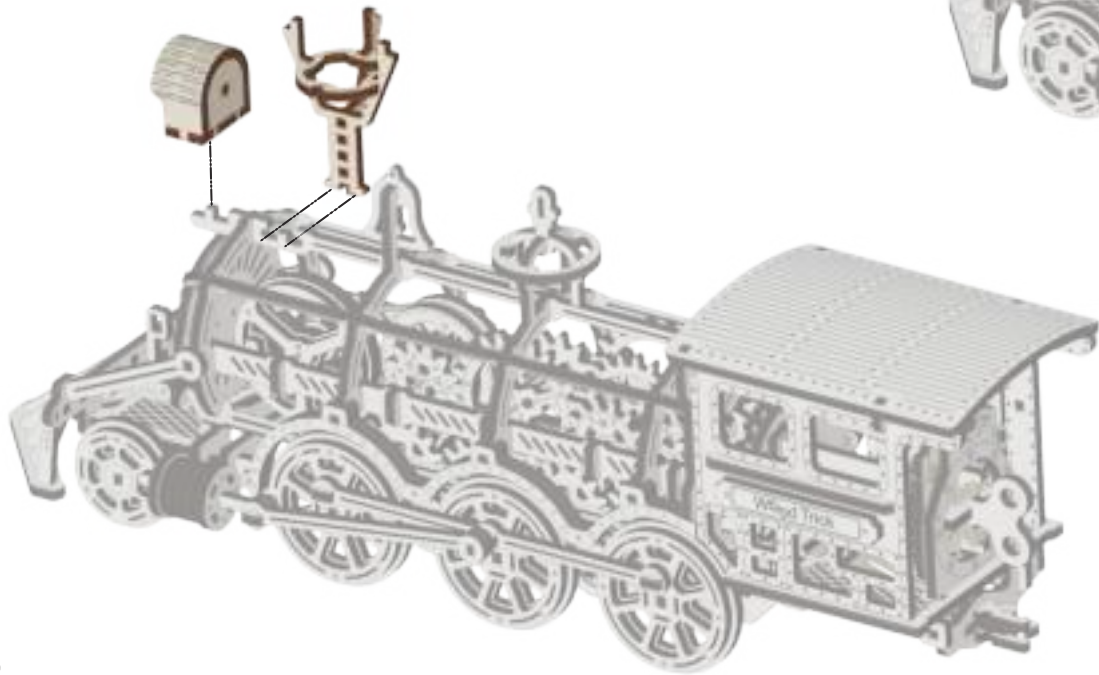

121

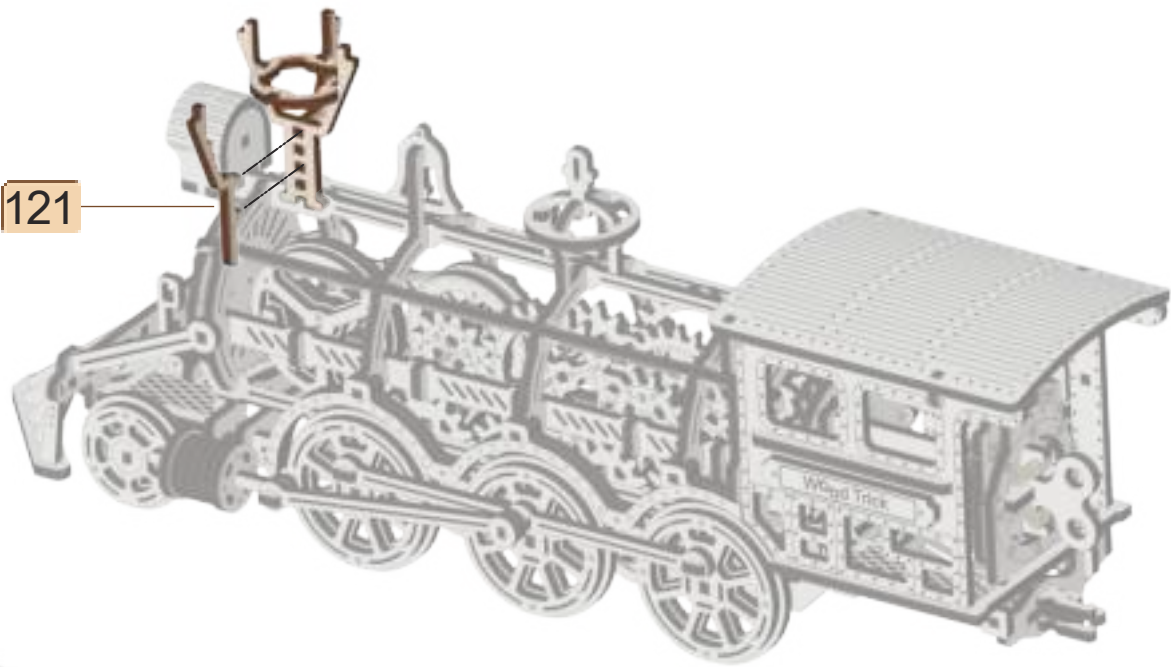

[49]

125



124



123



122

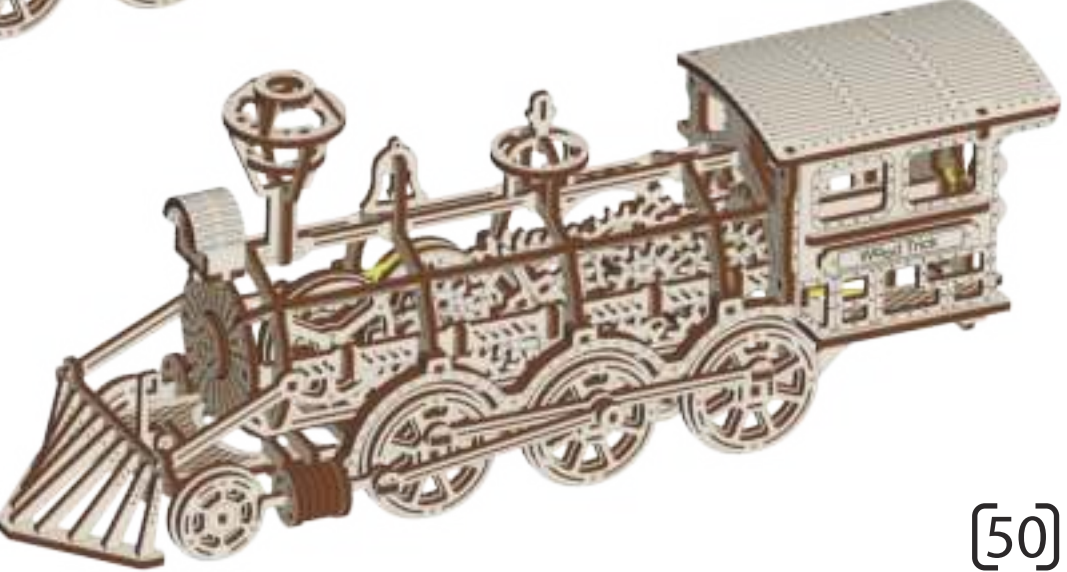
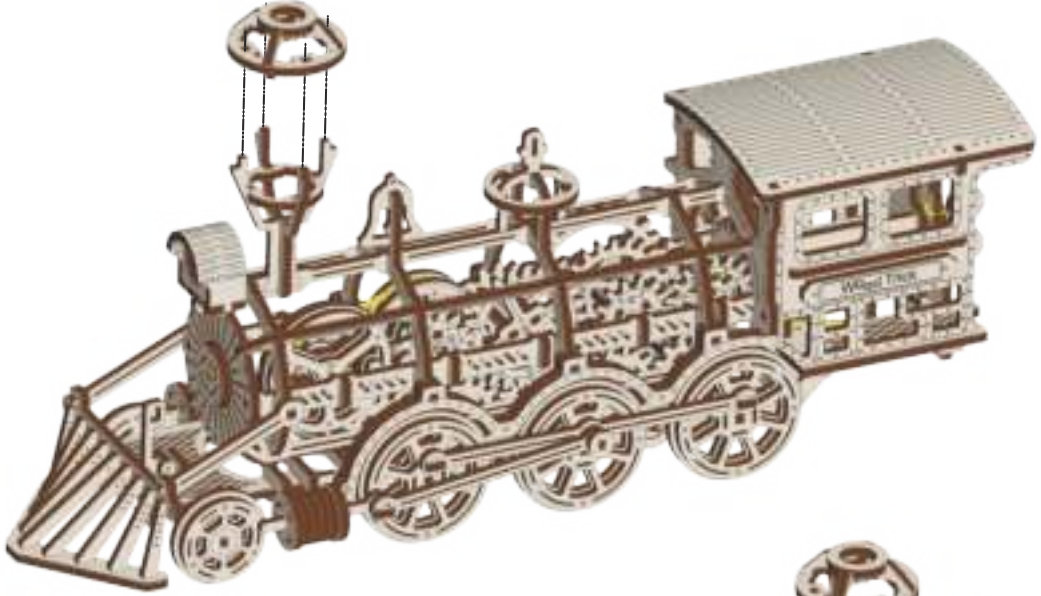

5

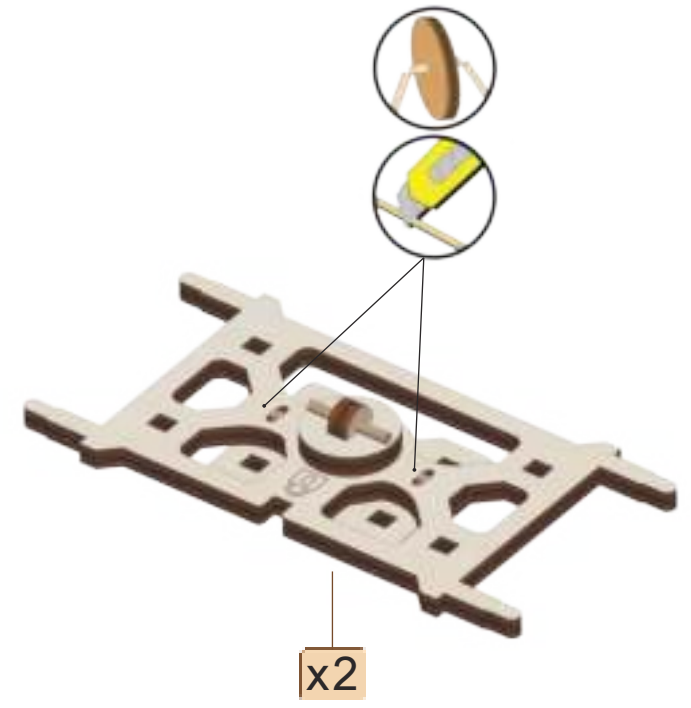
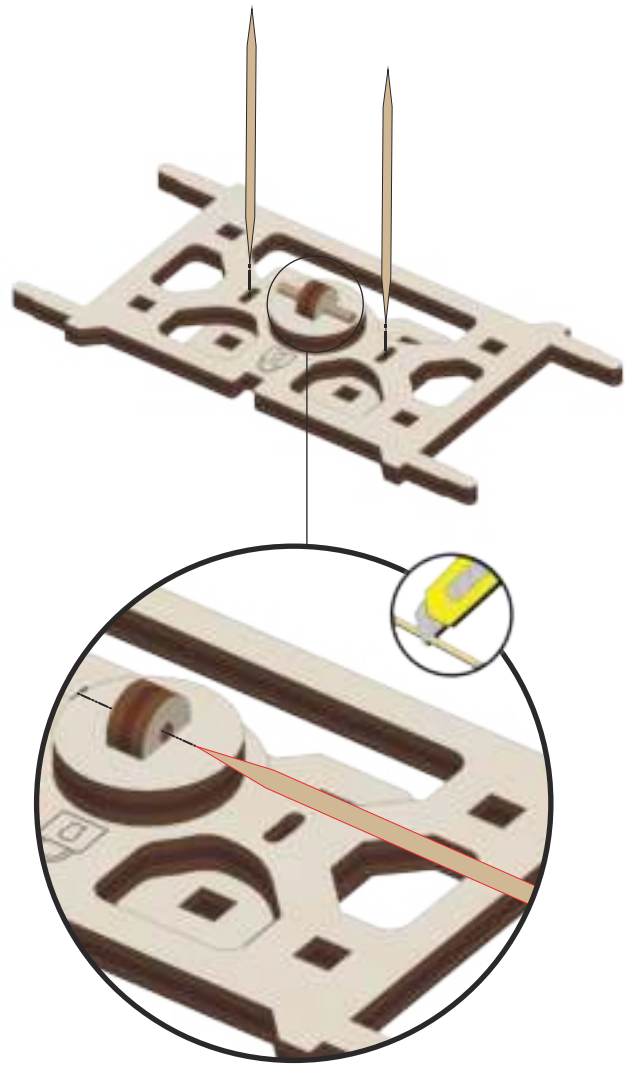
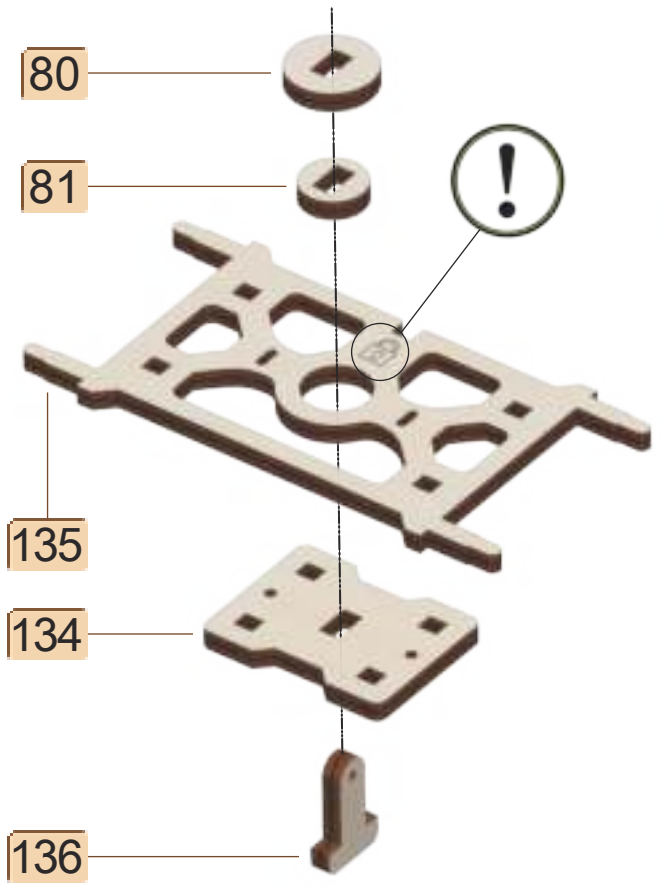
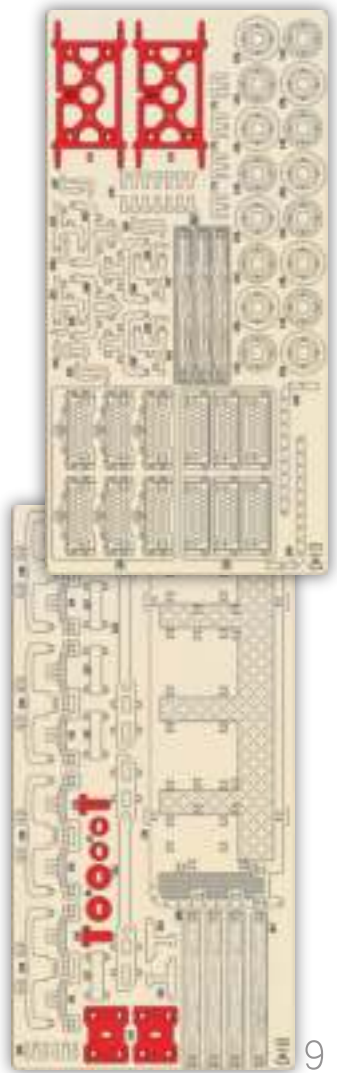

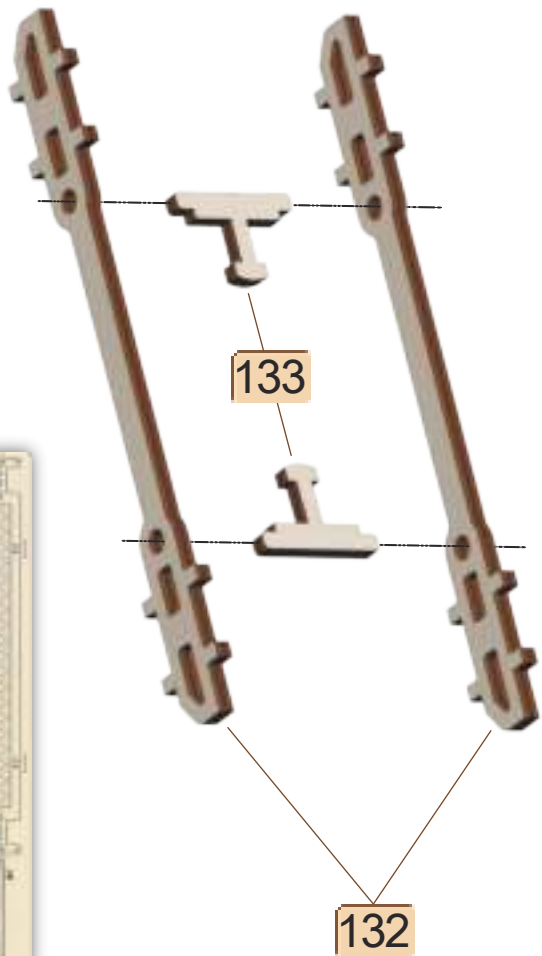
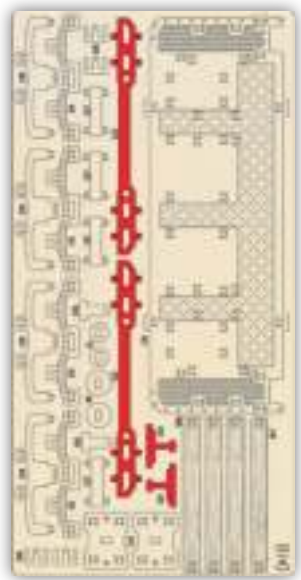

9

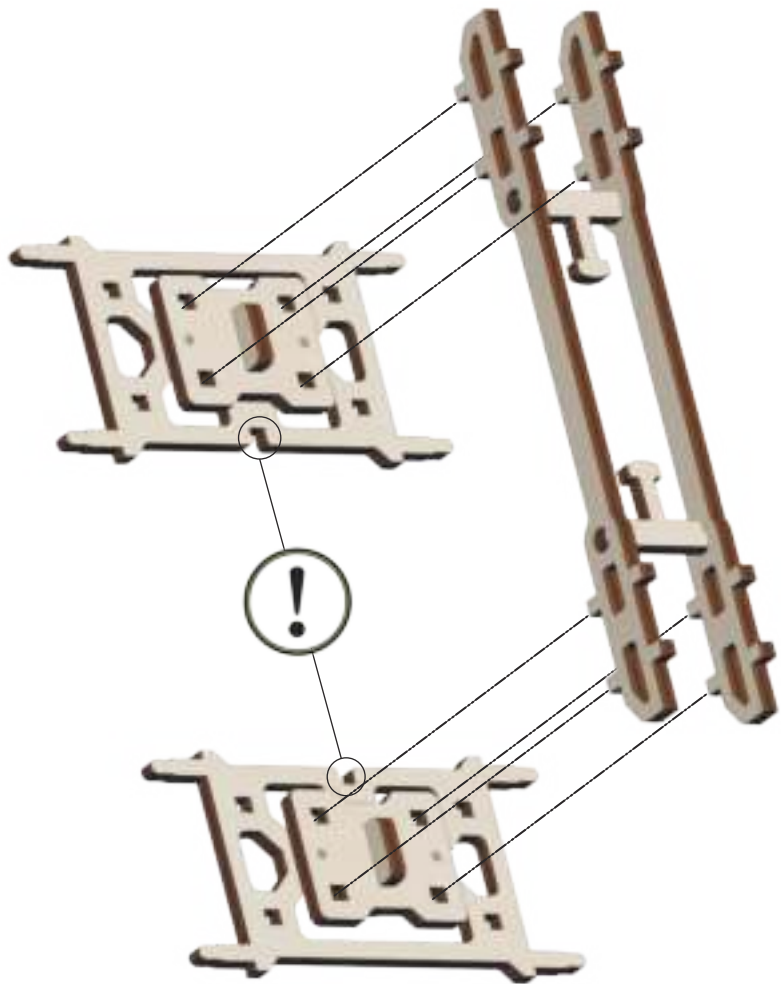

[52]

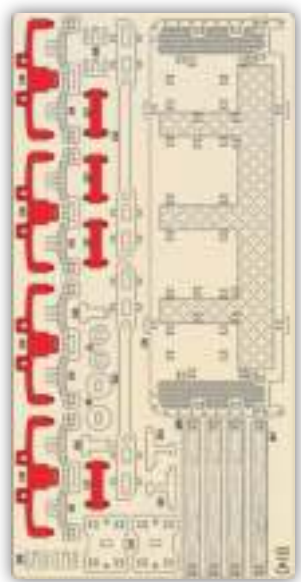

9

138

137

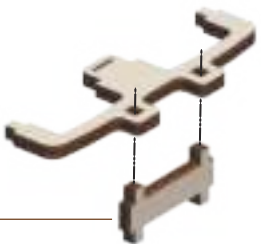

x4

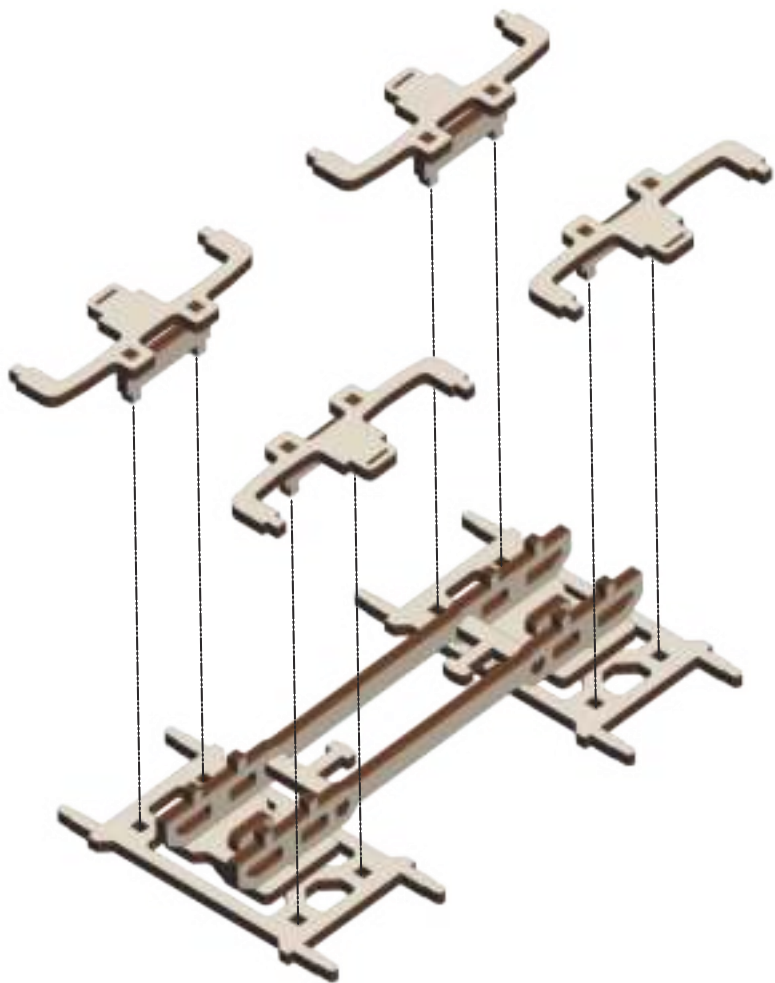

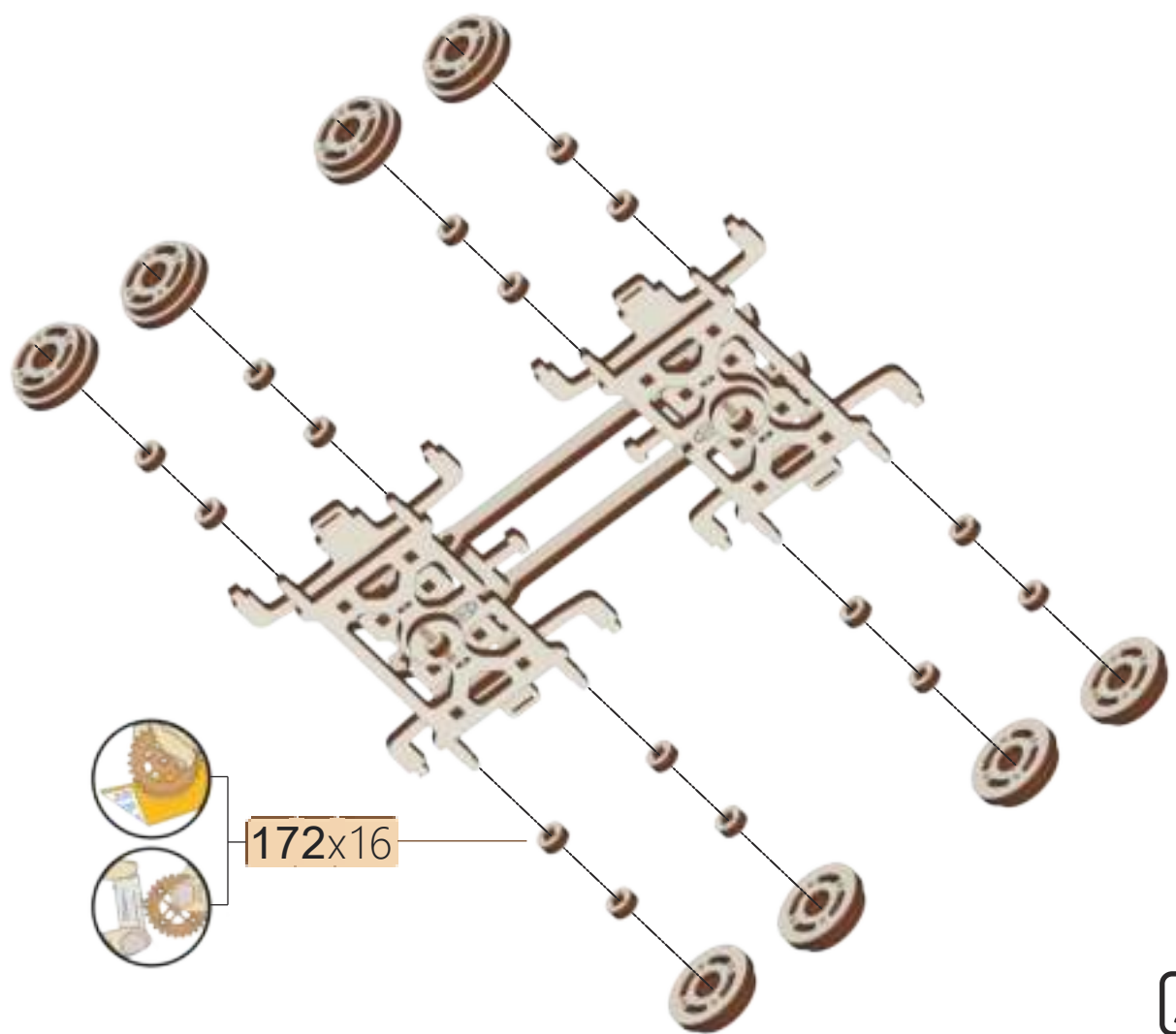
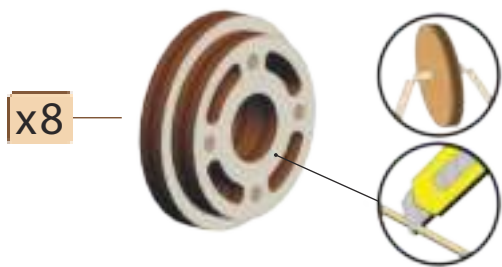
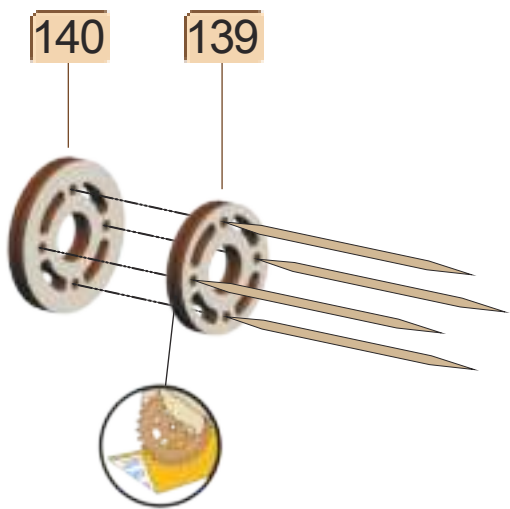
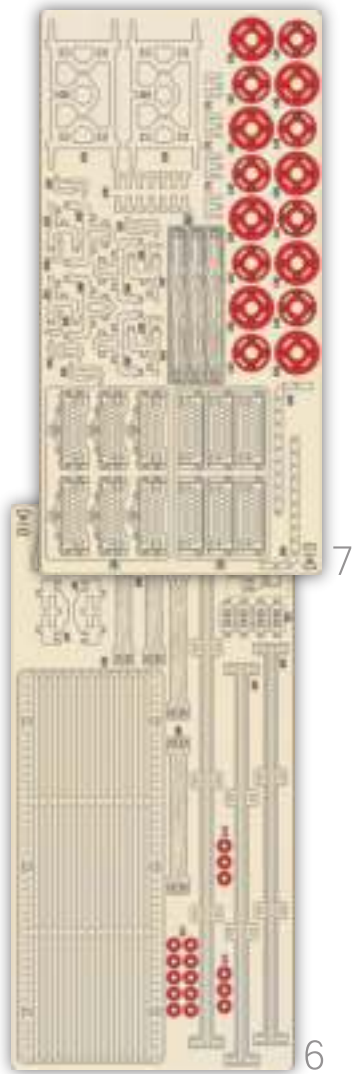

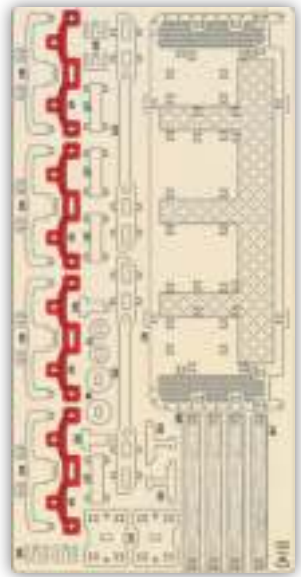

9

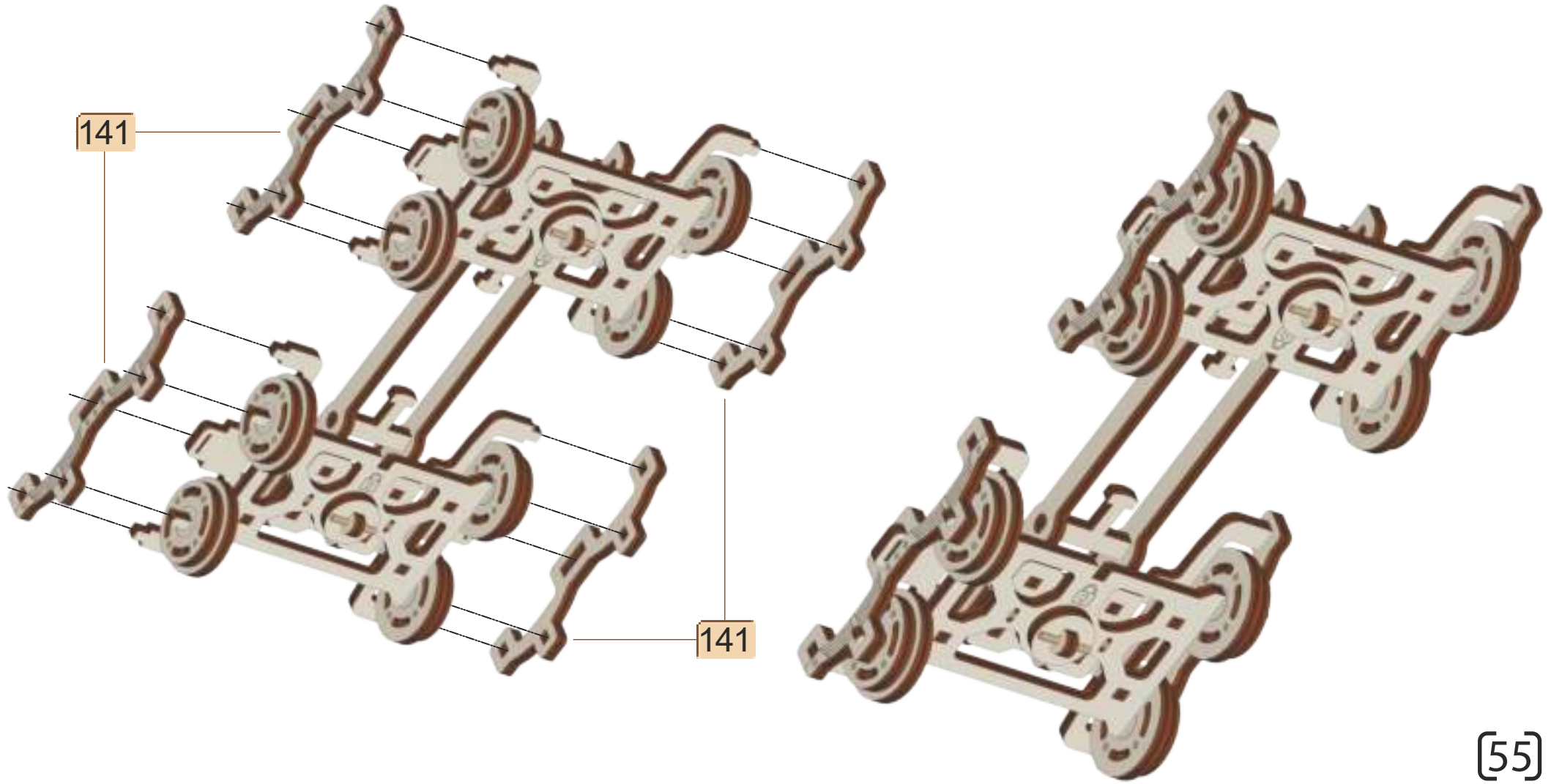



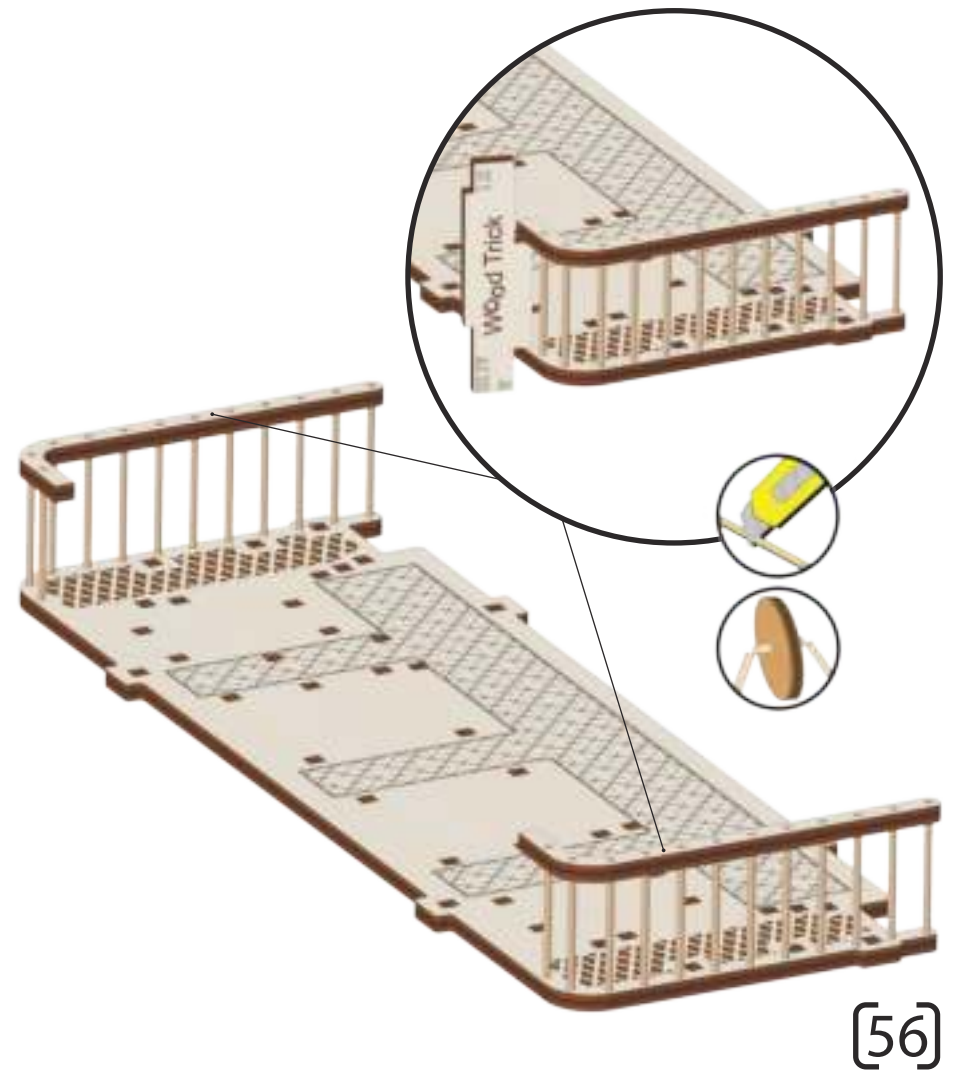
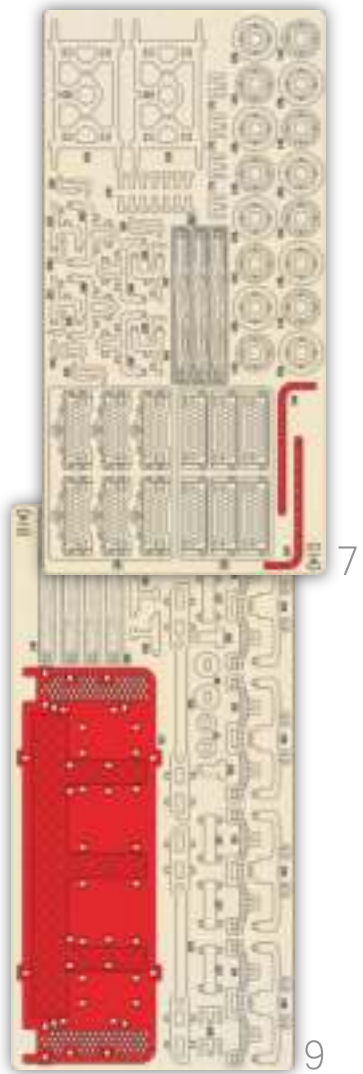

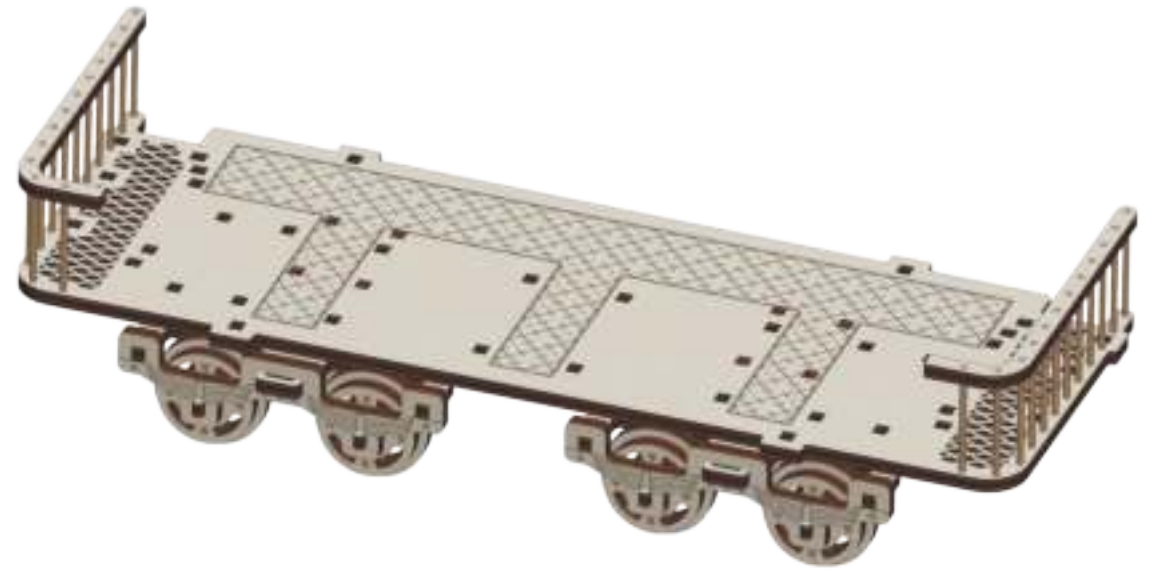
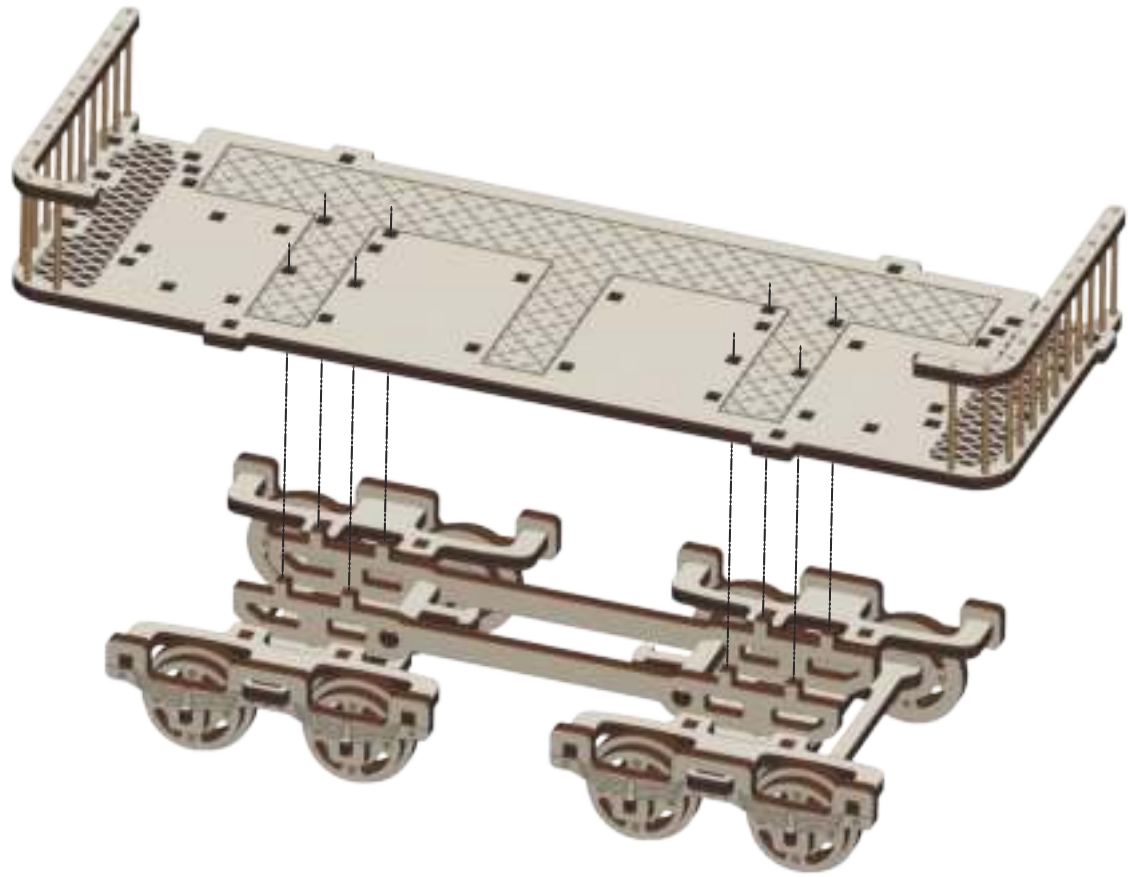

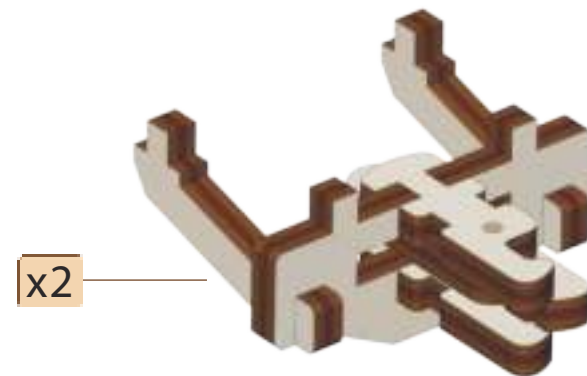
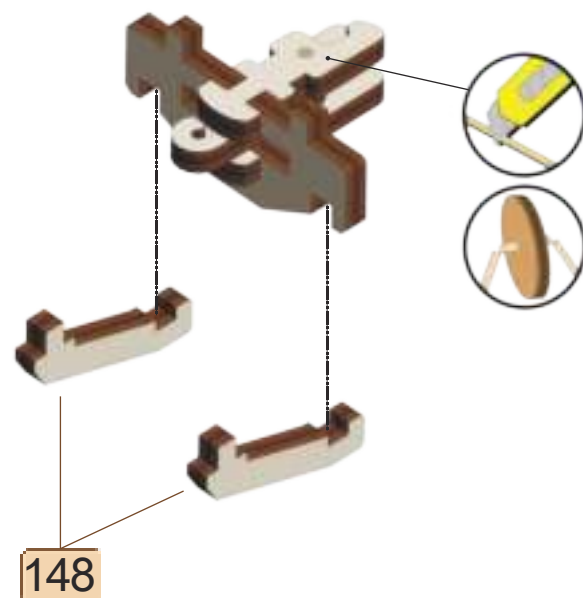
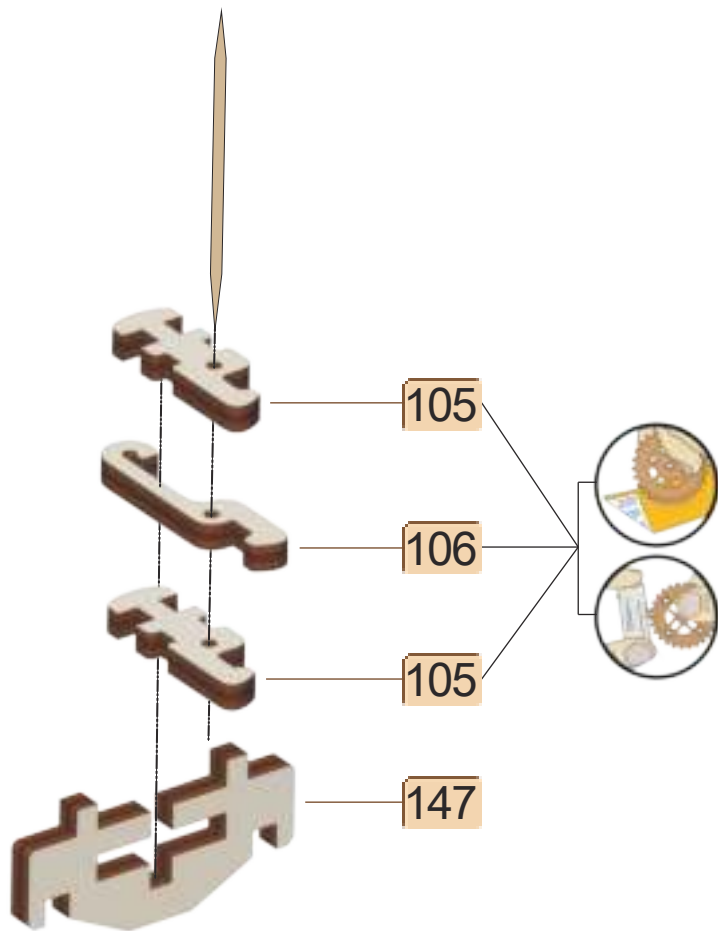
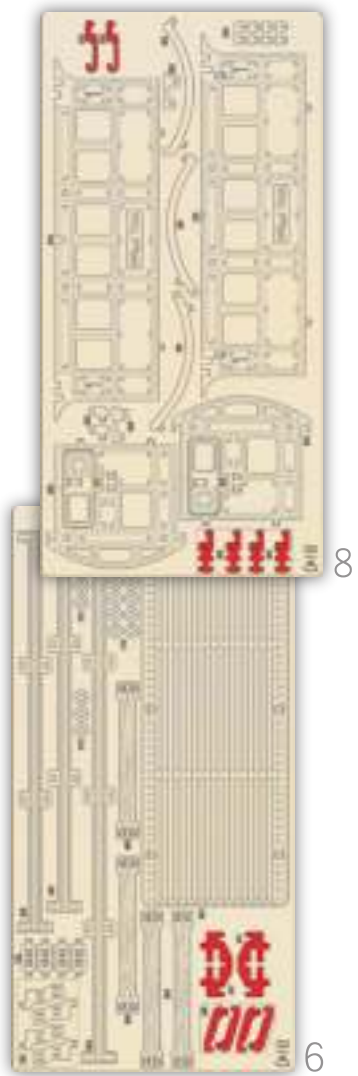

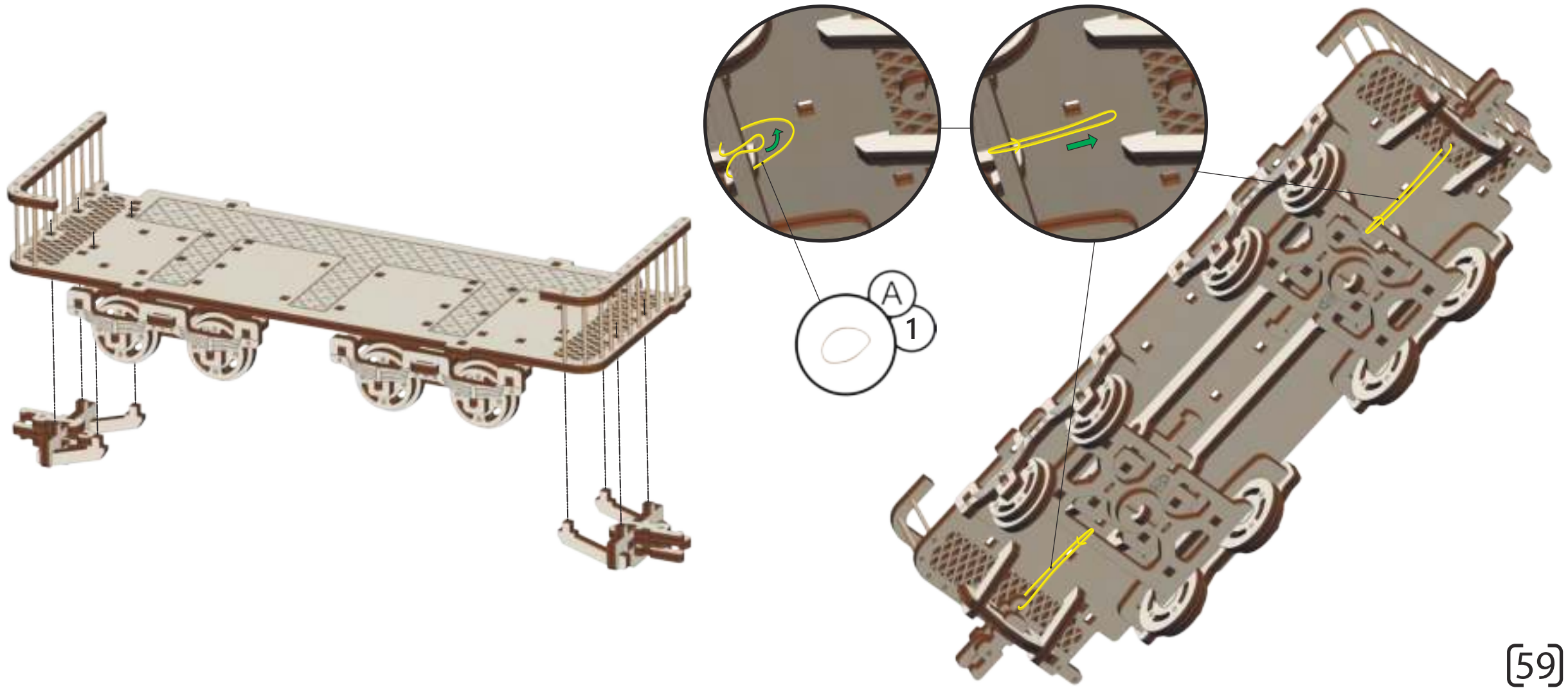

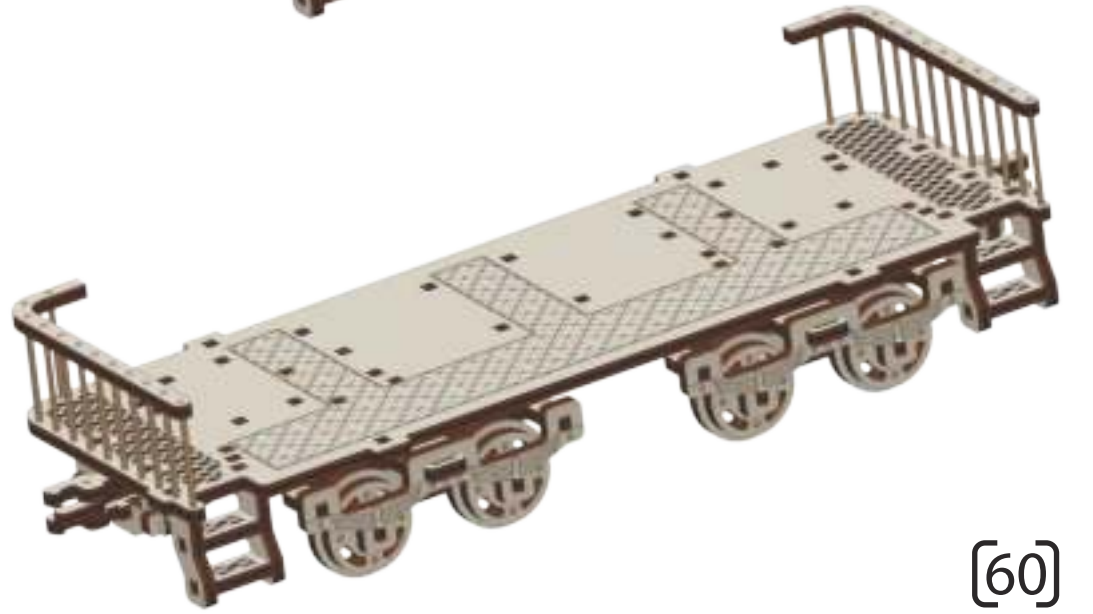
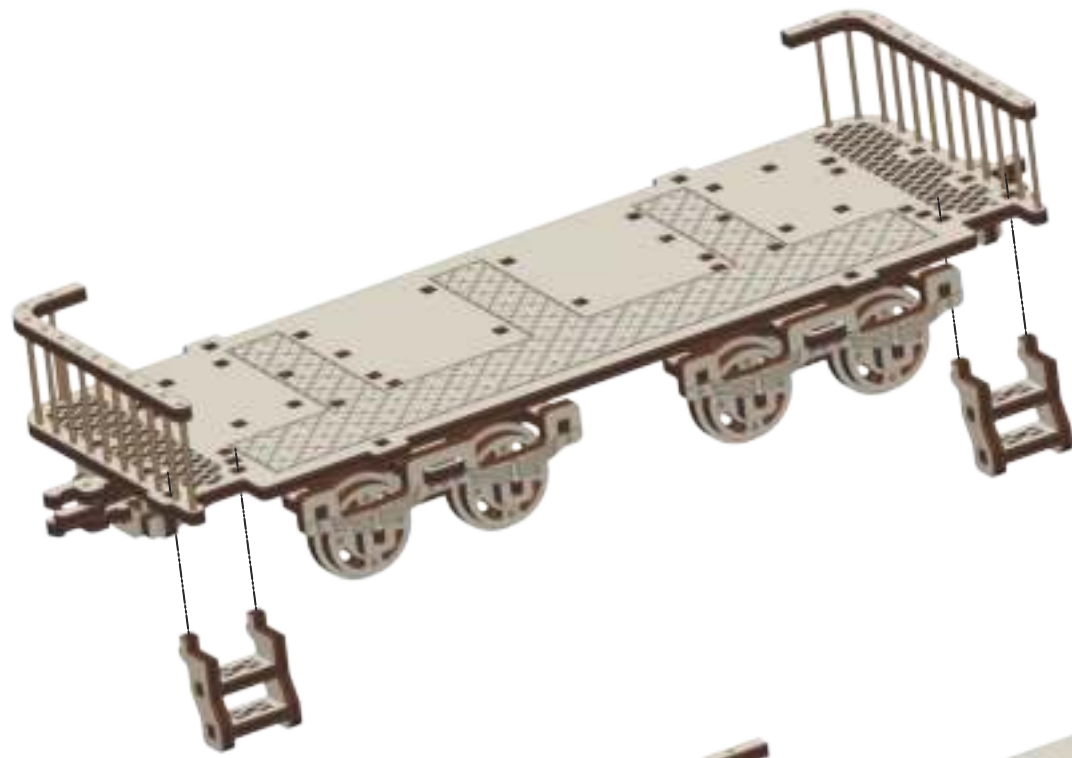
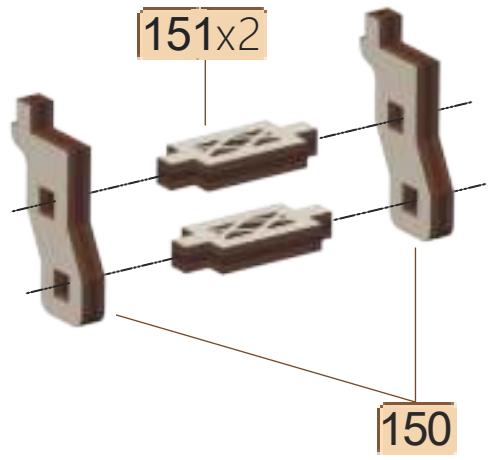

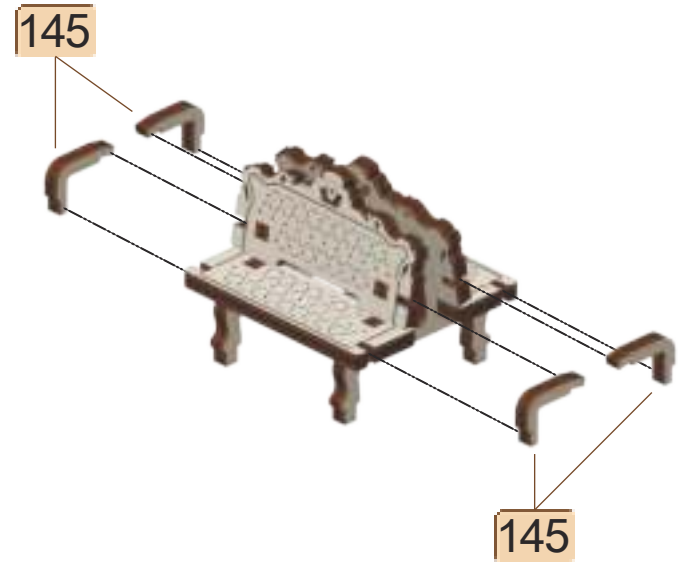
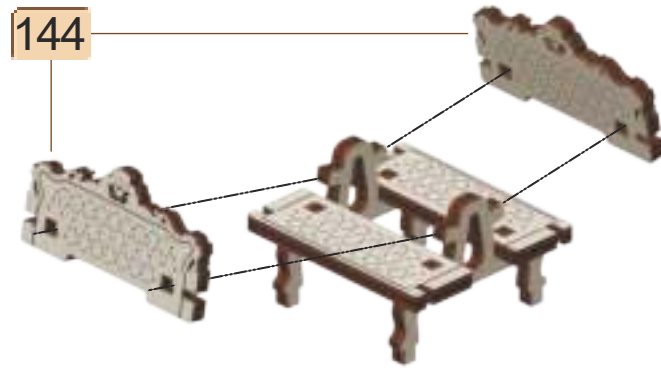
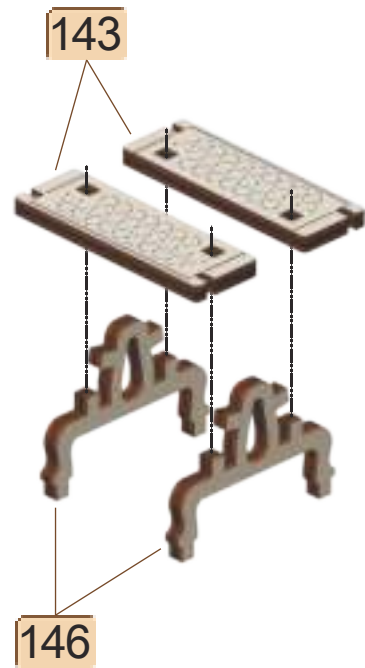
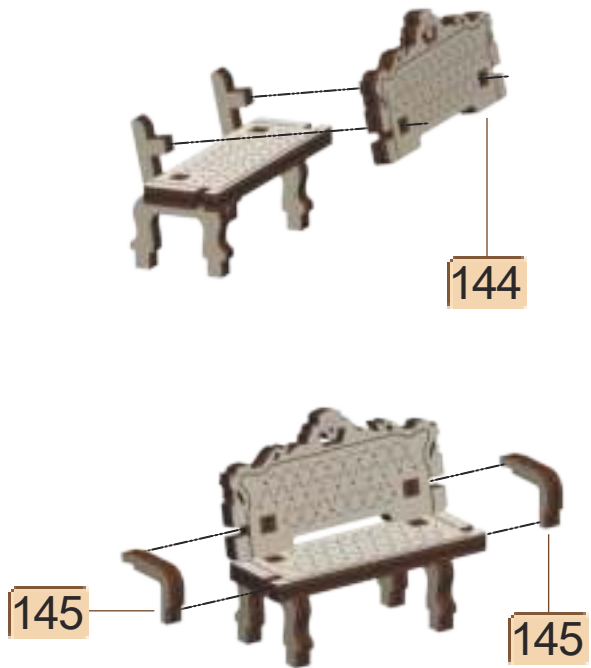
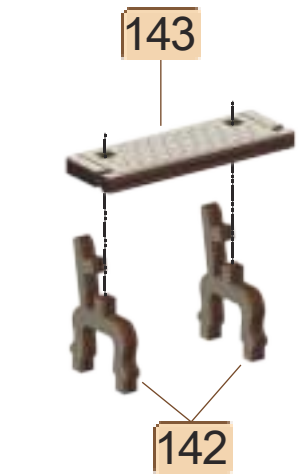

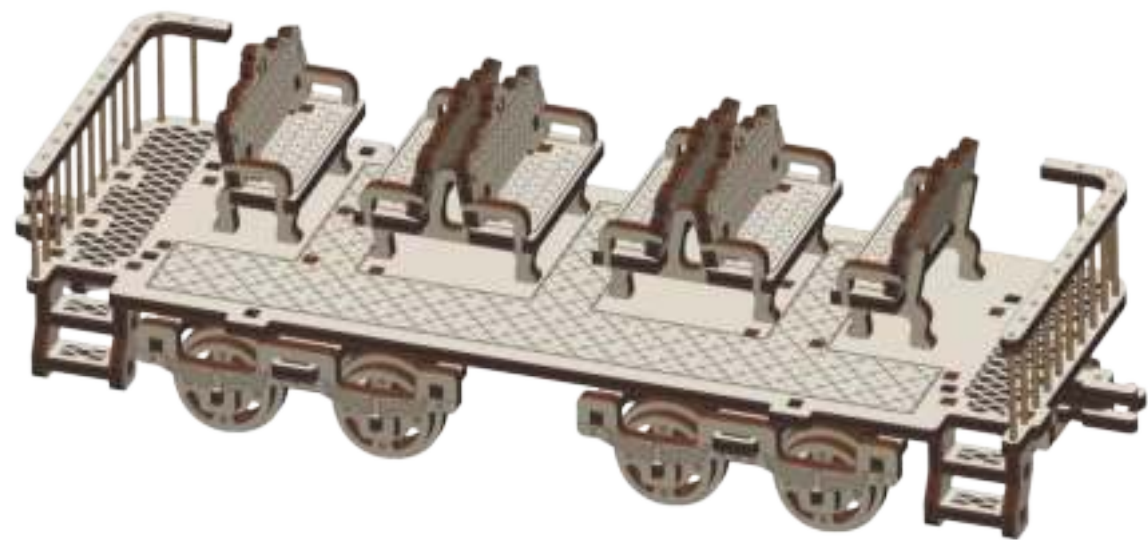
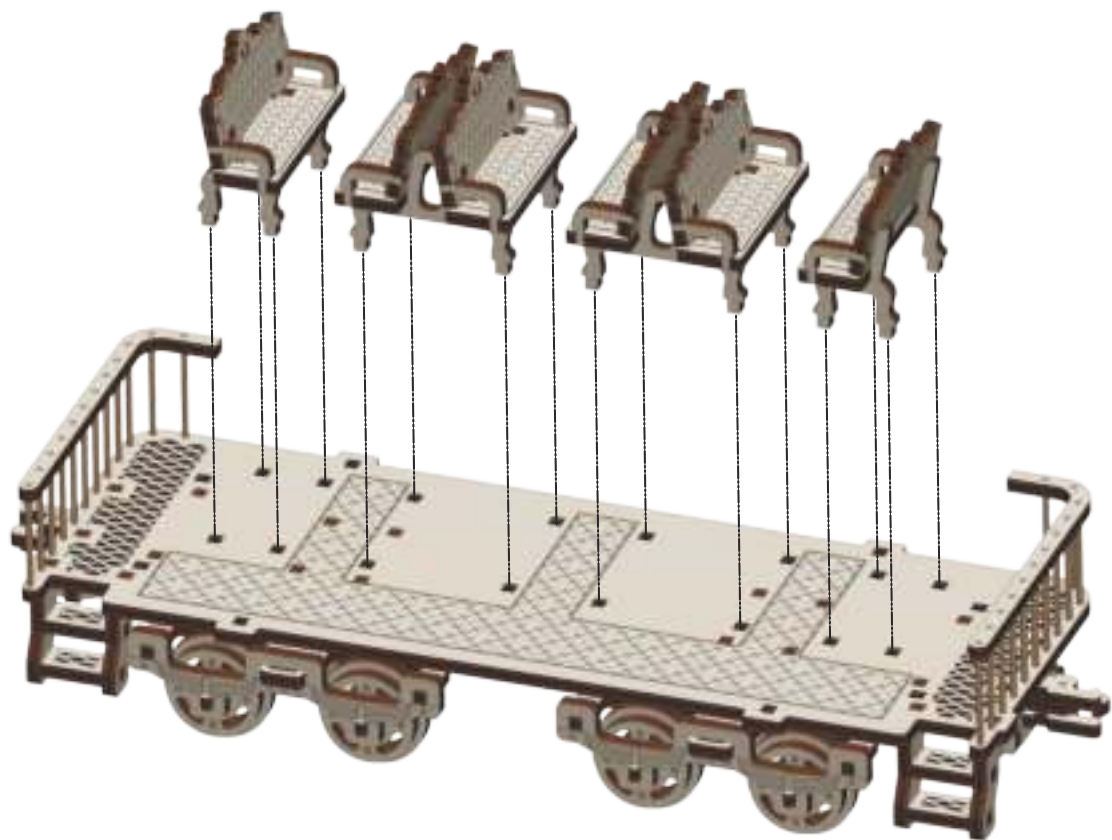

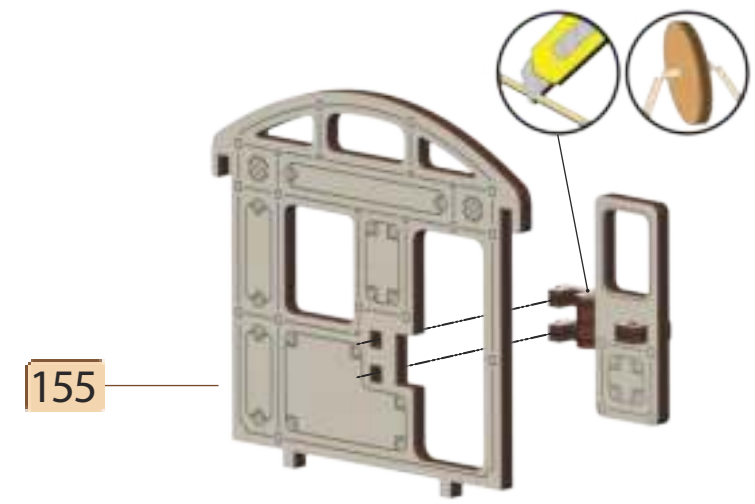
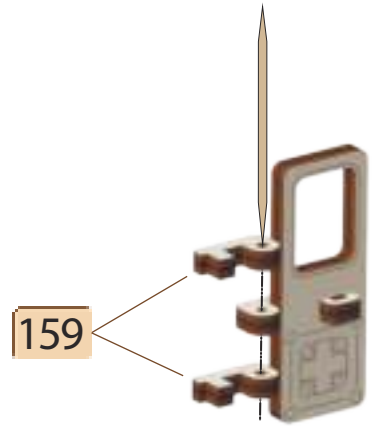
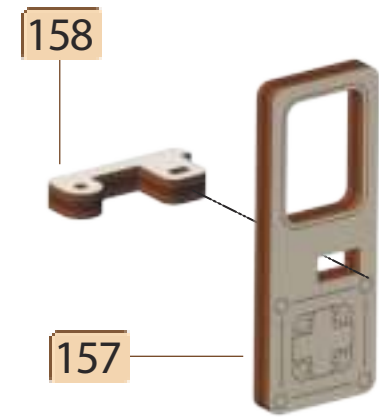
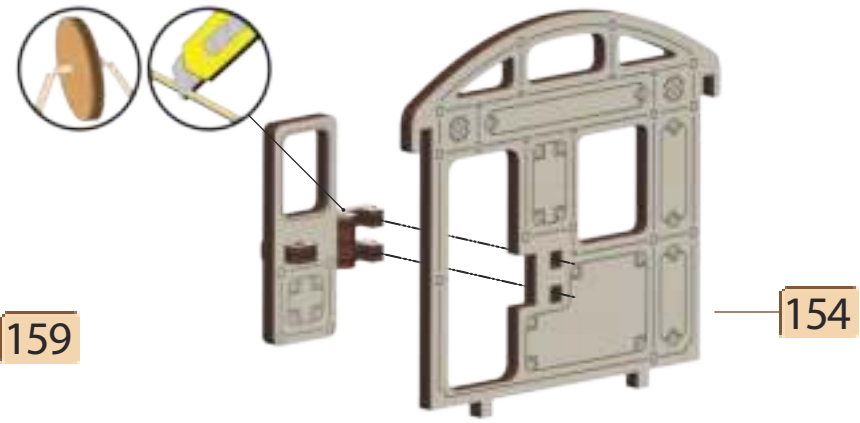
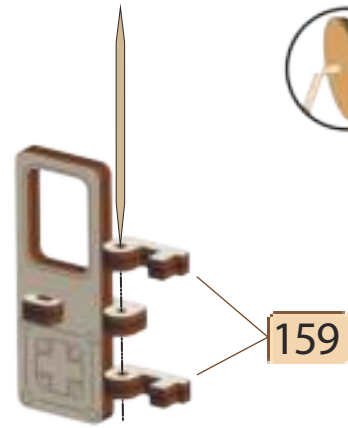
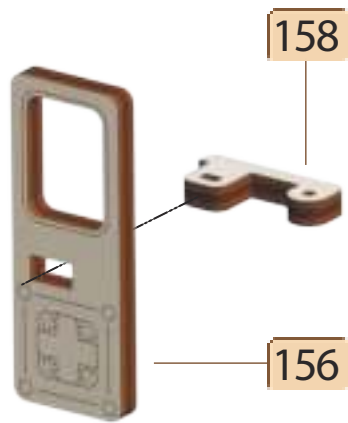



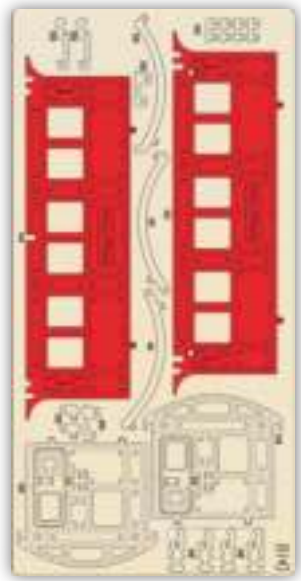

8

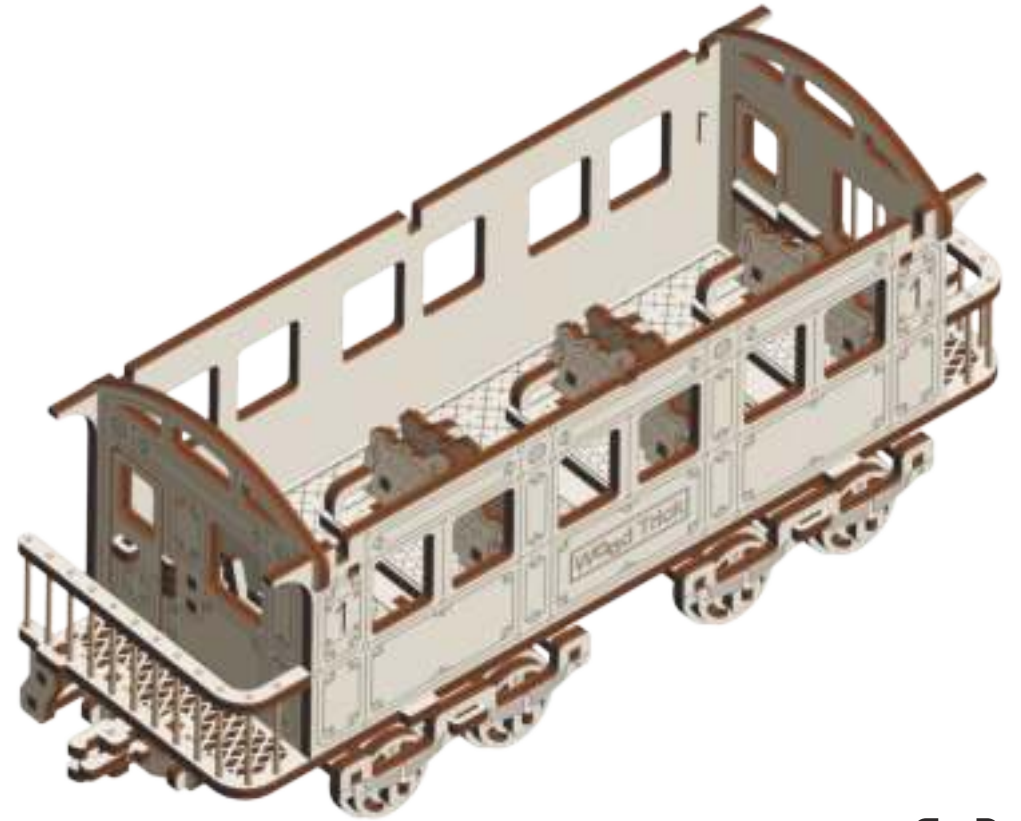
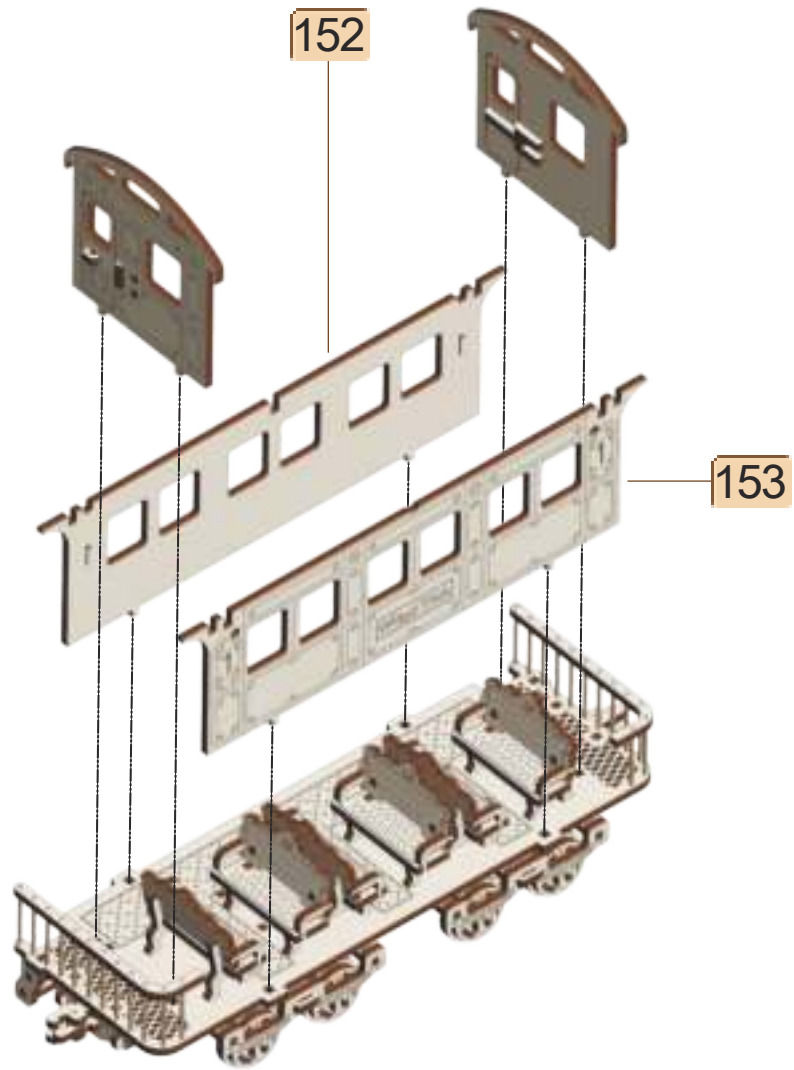

[64]

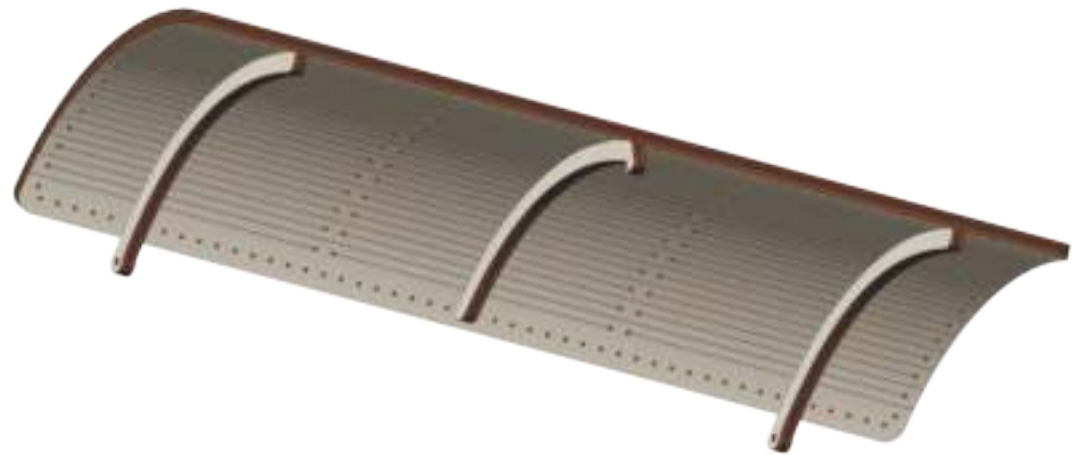
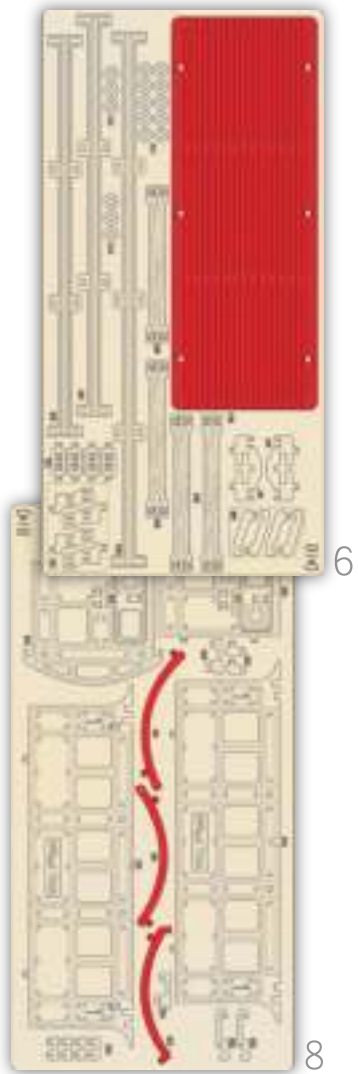

160

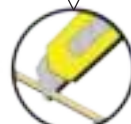
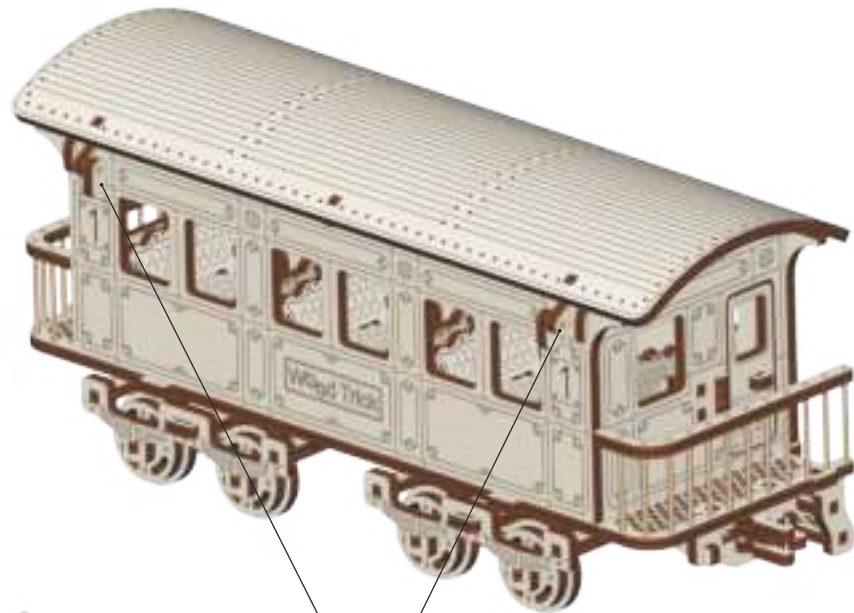
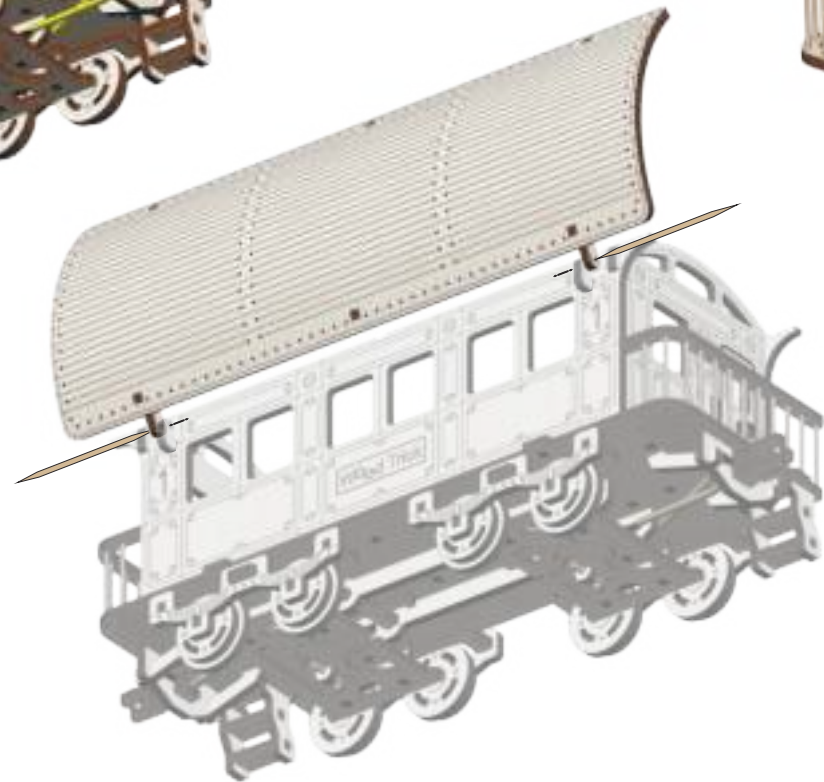
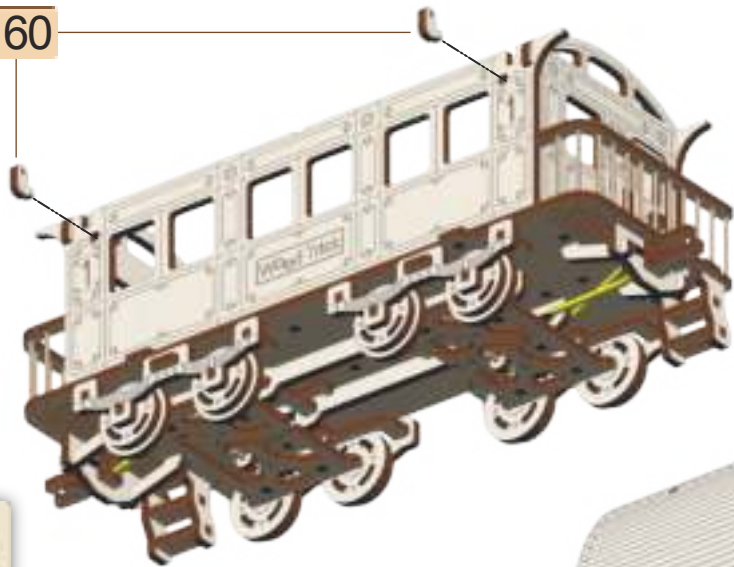

8

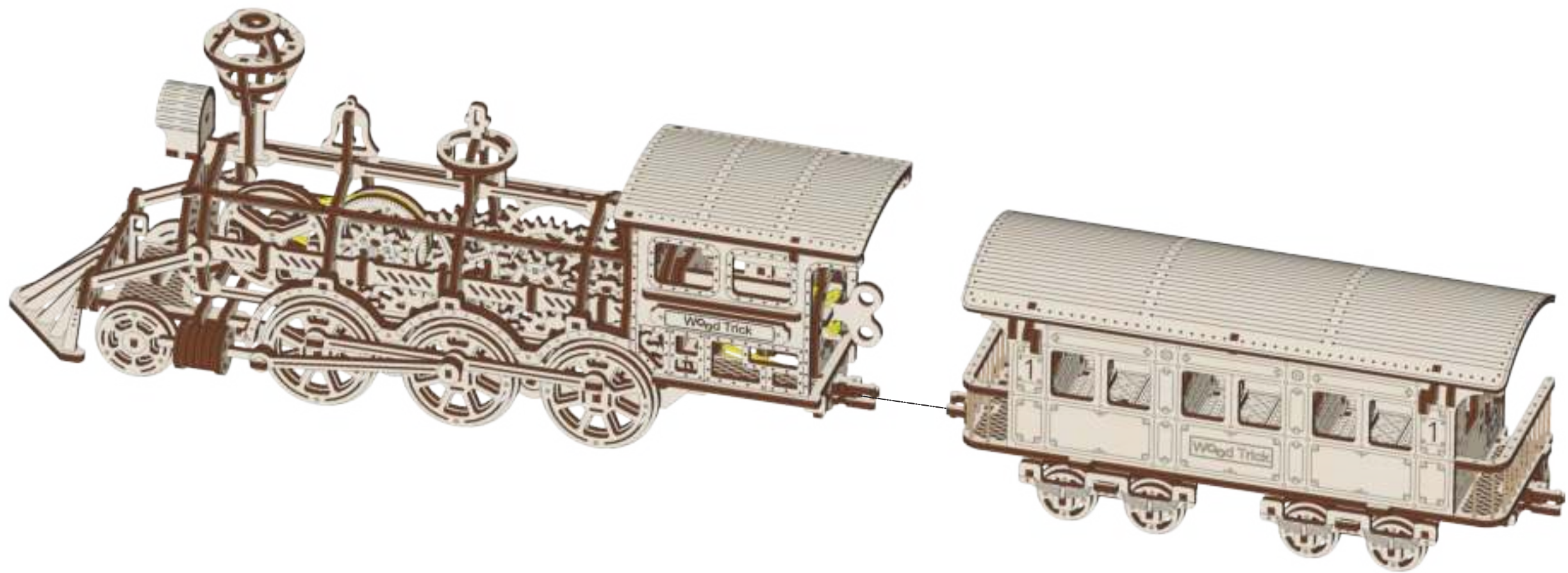

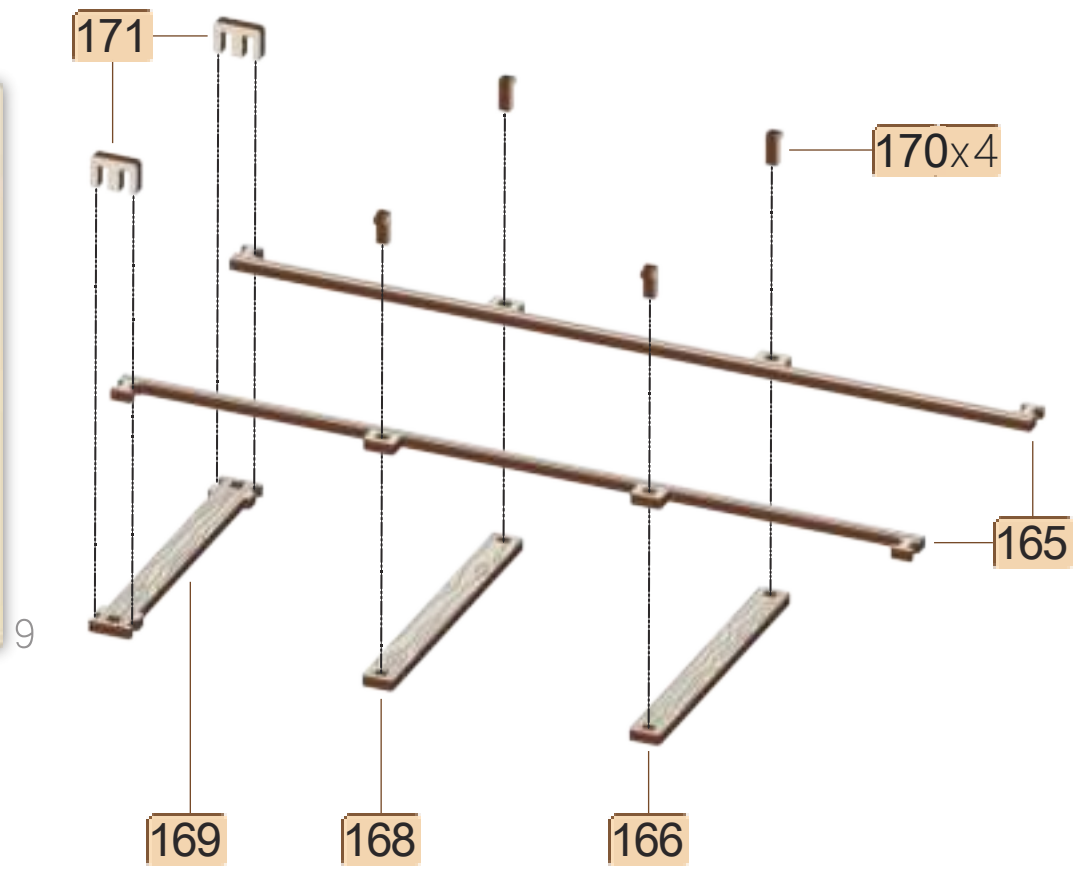
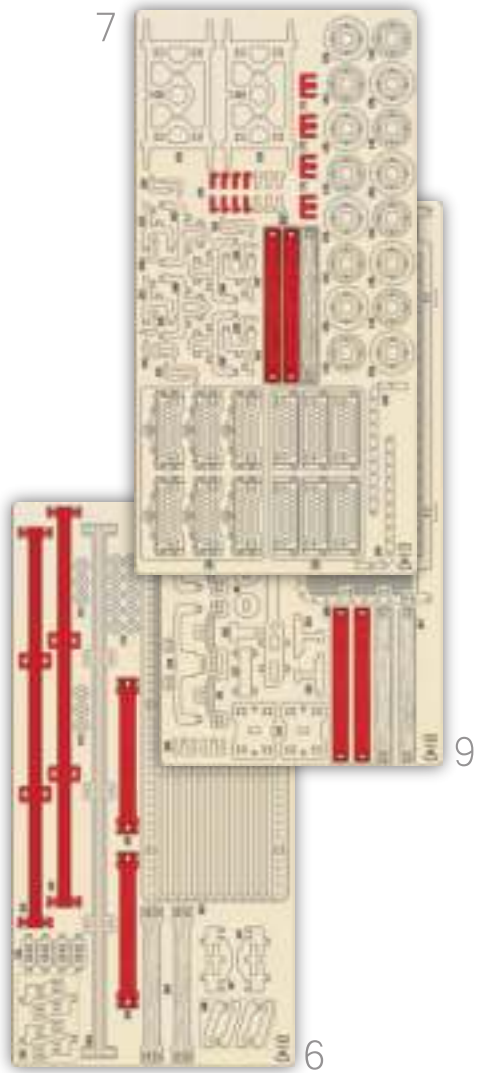

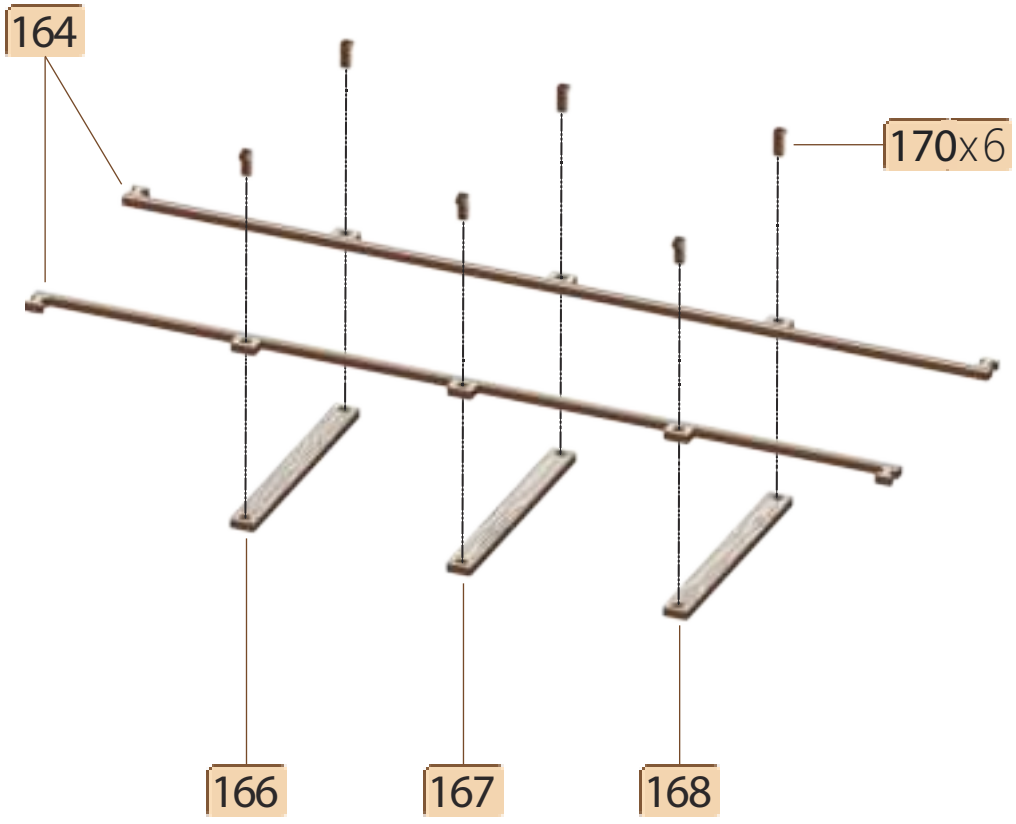
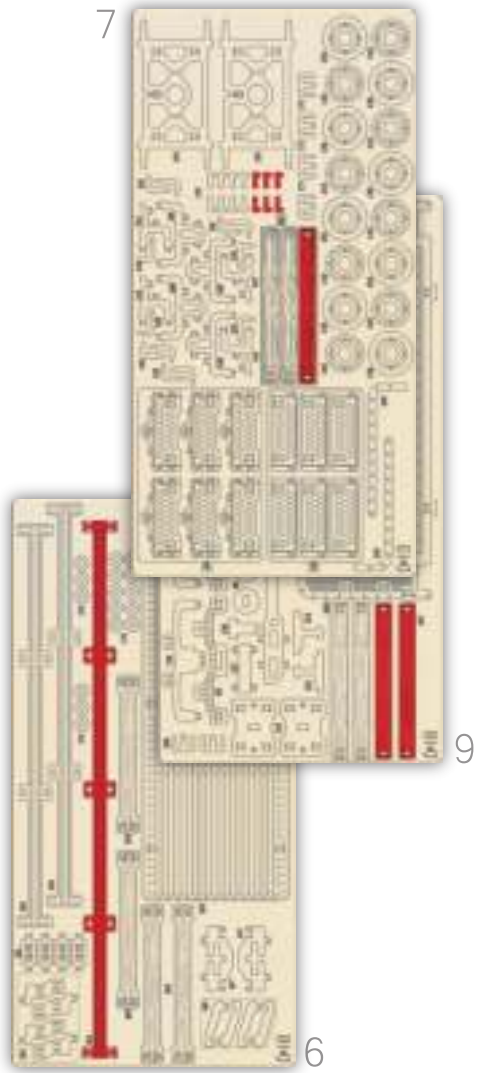

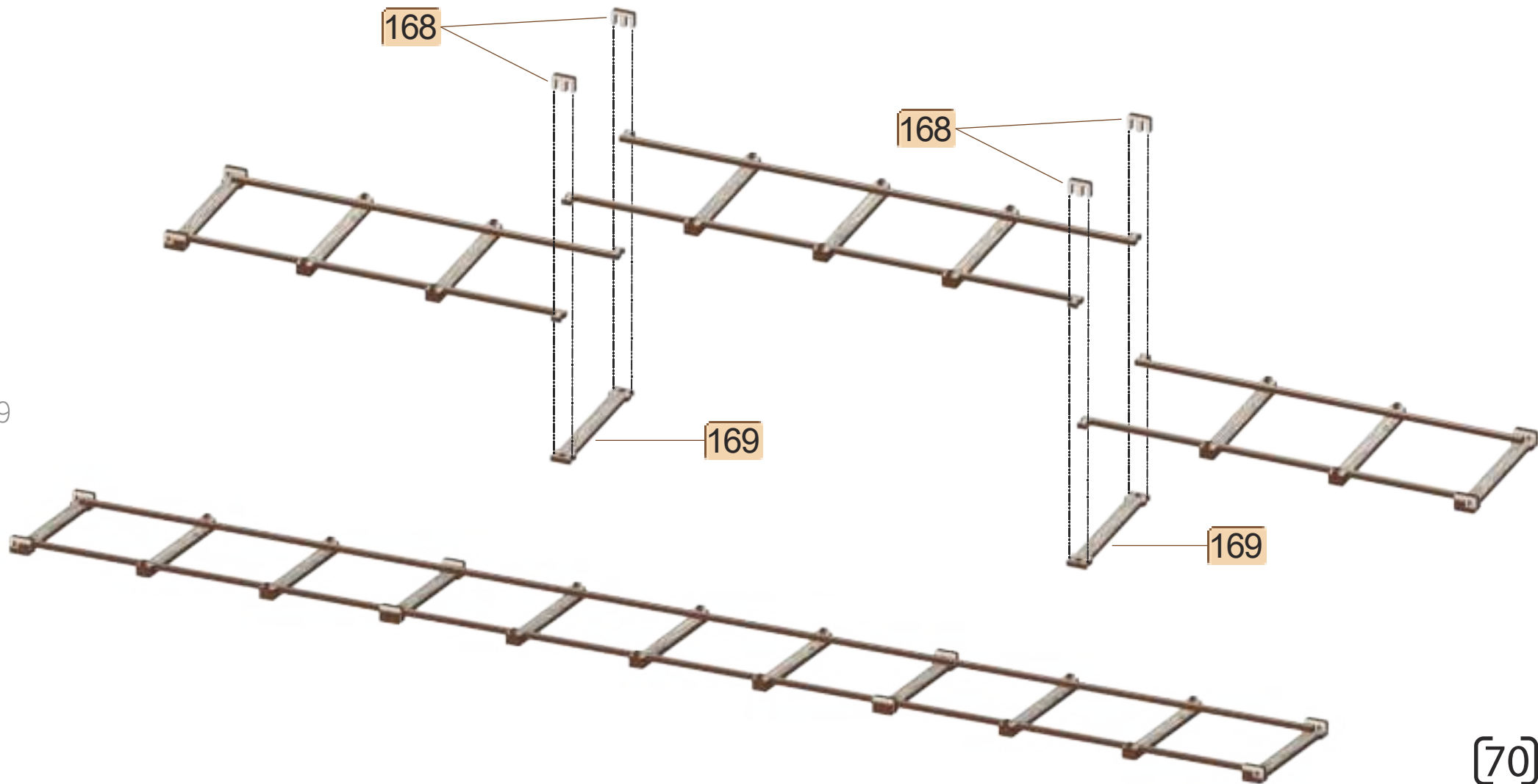
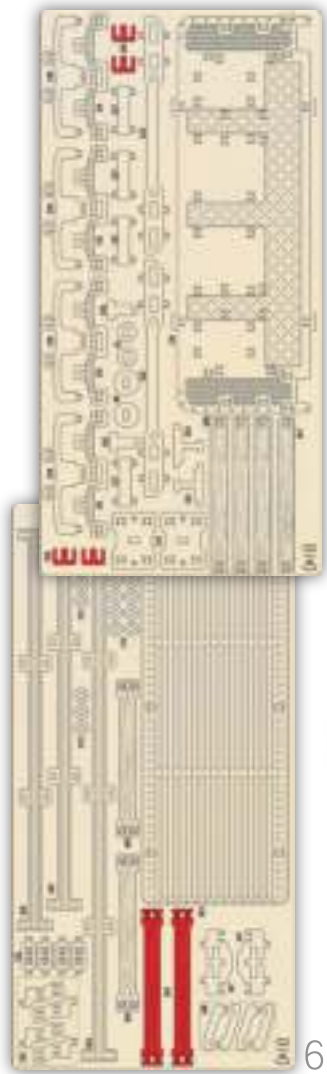

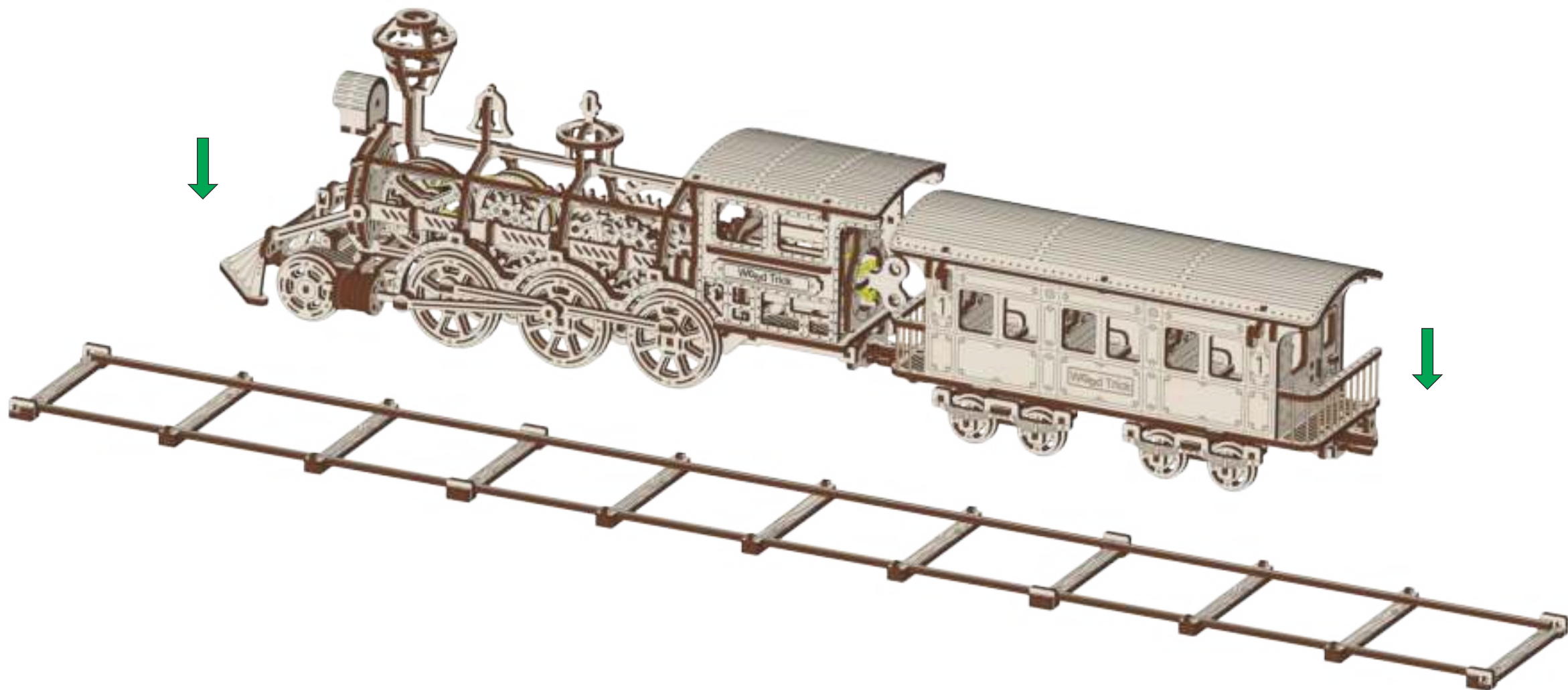



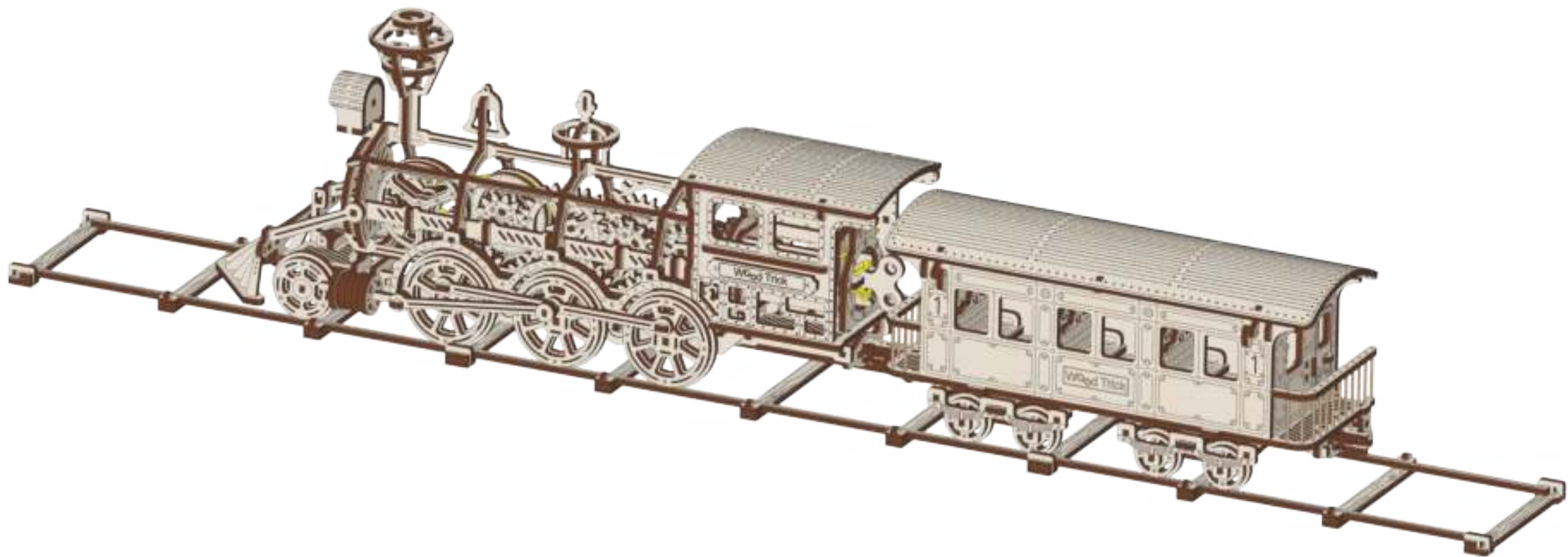

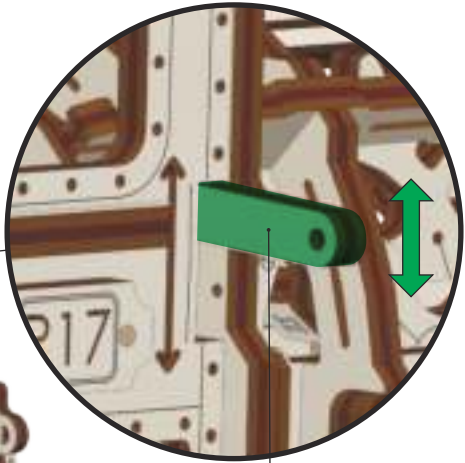
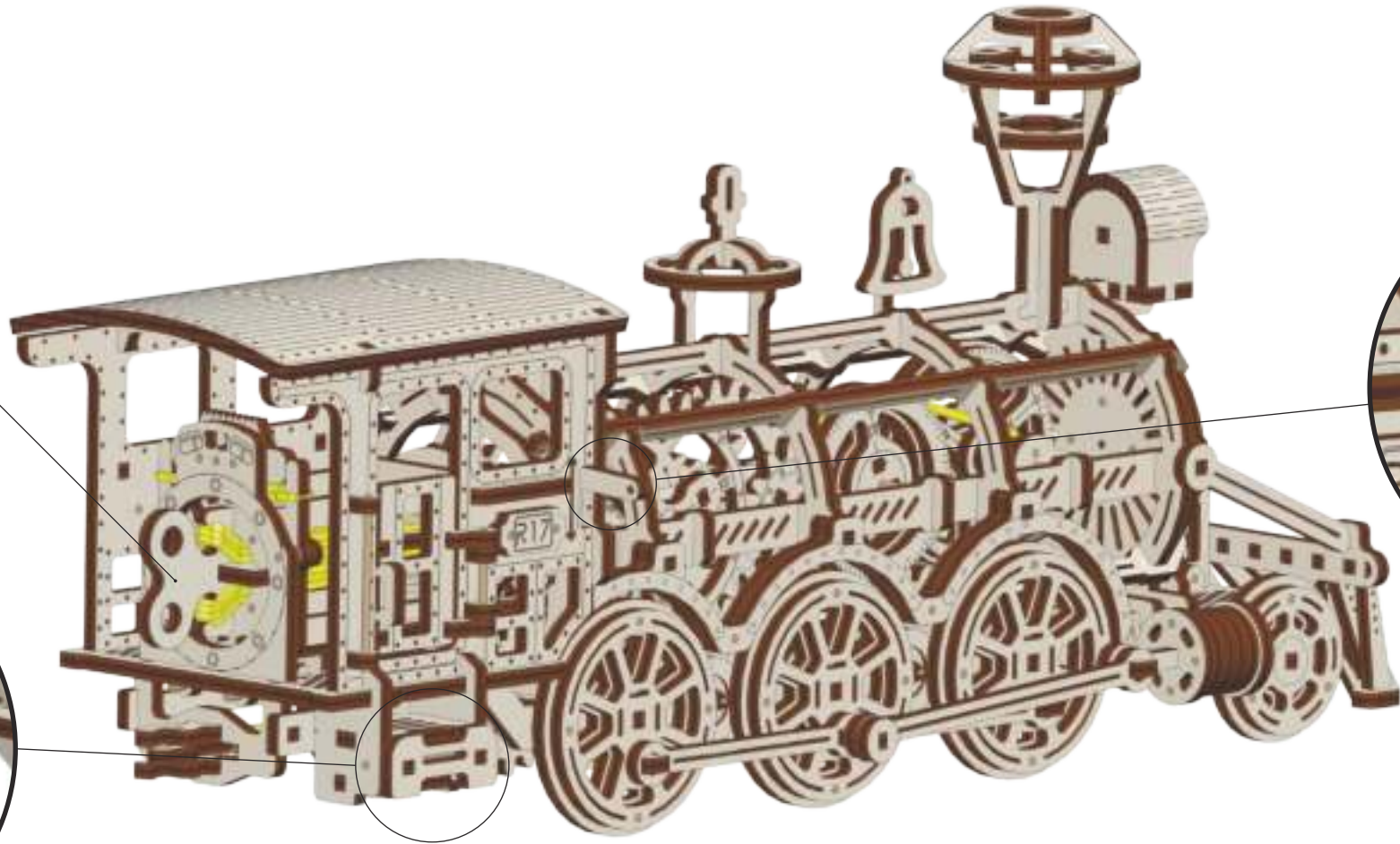
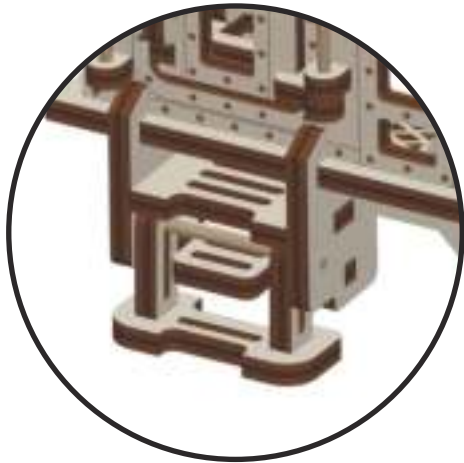

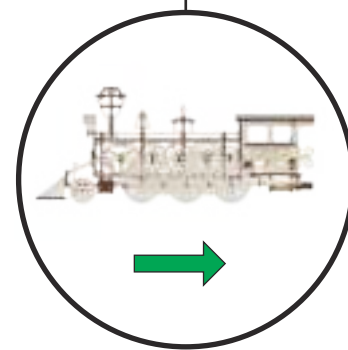
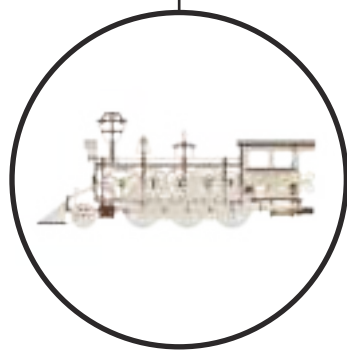
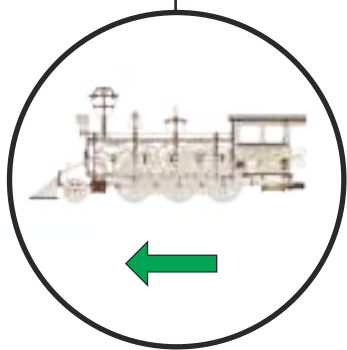
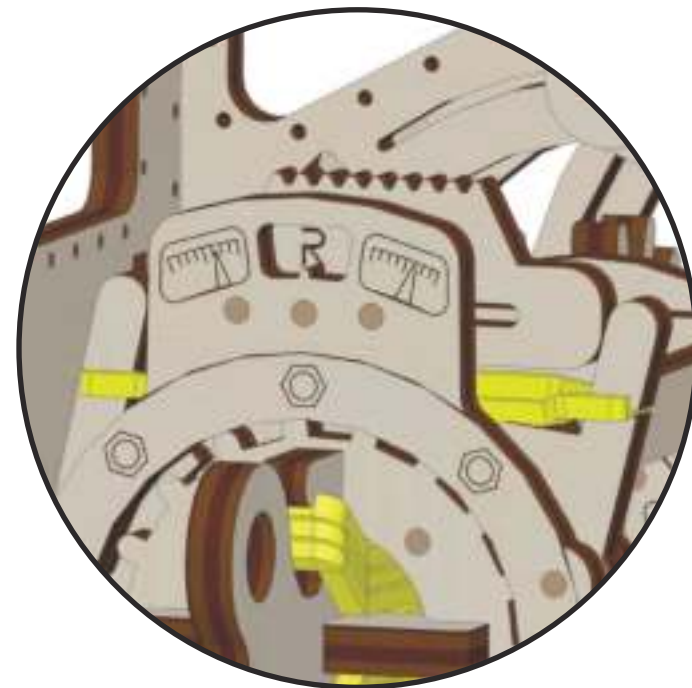
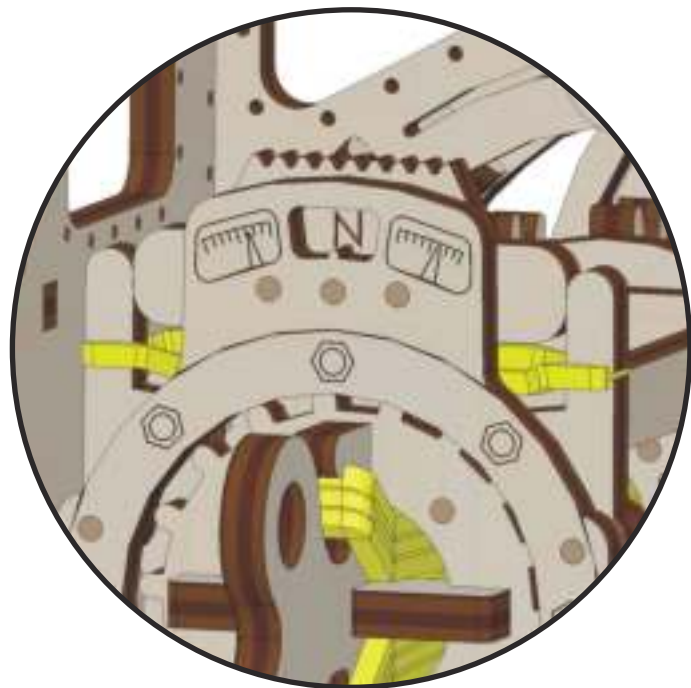
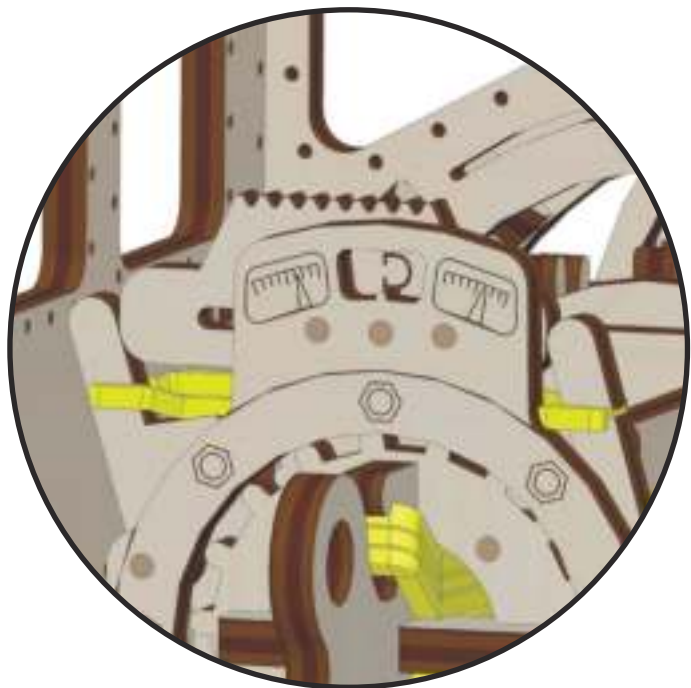

# PROGRESS & DEVELOPMENT

It is hard to overestimate the role locomotives played in the history of the modern world. Their impact was huge. They made heavy loads transportable and almost any previously hard-to-achieve place a rail ride away. The modern world is forever thankful to those steamy heavyweights. We in WoodTrick love locomotives. To say the least, we are huge fans. Here is a couple of facts for you:



## 1920S

When the mechanical stoker mechanism was invented and replaced hand stokers who had been stoking locomotives with wood and coal by hand for nearly a century.

## 3 TYPES

There are three types of locomotives: steam, diesel, and electric. Steam and diesel locomotives produce their own power, being truly self-propelled vehicle systems.

## BIG BOYS

The name for the Union Pacific Railroad's 4-8-8-4 Mallets—the special jointed locomotives invented by Anatole Mallet in 1887 for riding railroads in mountains. It had two engines and could make sharp bends. Being 133 feet long, they were the biggest steam locomotives ever built.

## 100 YEARS

Steam was the major source of rail power all over the world. Today, however, only a few steam locomotives are still at work, giving up their lead position to diesel-powered locomotives.

Follow us on YouTube /woodtrick  
Instagram @woodtrick | [www.woodtrick.com](http://www.woodtrick.com)

# WOOD TRICK

## CHECK OUT OTHER SERIES



SPECIAL FORCES SERIES



ELECTRIC SERIES



MECHANISMS SERIES



VINTAGE MACHINERY SERIES