

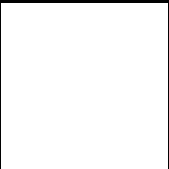

Booklet available in English on
Heft in deutscher Sprache erhältlich auf
Livret disponible en français sur
Libretto disponibile in Italiano su
Folleto disponible en español en
如需中文版手册, 请访问





WELCOME

What started as a nights and weekends passion project for our designers in 2007 has now grown into a vibrant downtown filled with beautiful architecture, rich interiors, clever brick usage and an impressive population of happy minifigures. And what better way to celebrate 15 years of Modular Building than by creating one of the models most-often requested by fans.

Welcome to the beautiful, historic **Boutique Hotel!** Inspired by turn-of-the-century European architecture, the unique wedge-shaped structure showcases a myriad of elegant forms and delicate details. It's also packed with small stories and subtle references to earlier models in the Modular Building range. See how many you can spot!





From left to right:

Michael Psiaki
Astrid Graabæk
Wesley Alan Talbott
Torben Kidde Skov
Anderson Ward Grubb
Chris McVeigh
Jamie Berard

It's been an exciting 15 years of Modular Building! Here are all the models and many of the designers who made it happen.



Anderson Ward Grubb
Designer of the 10297 Boutique Hotel



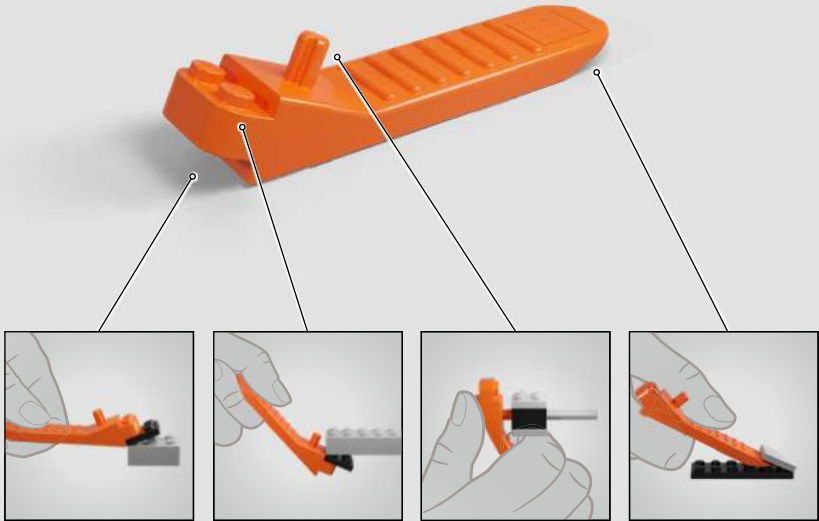
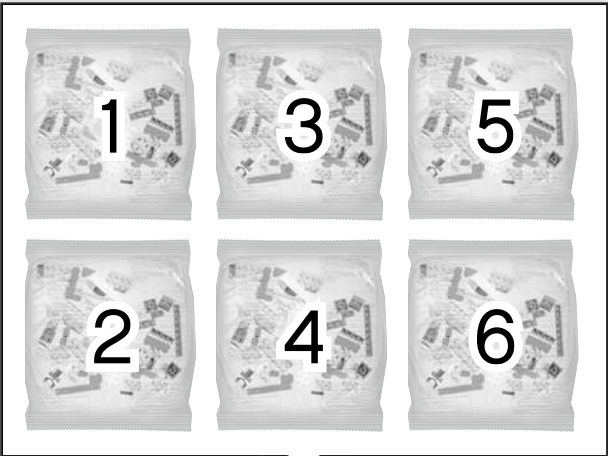

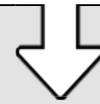
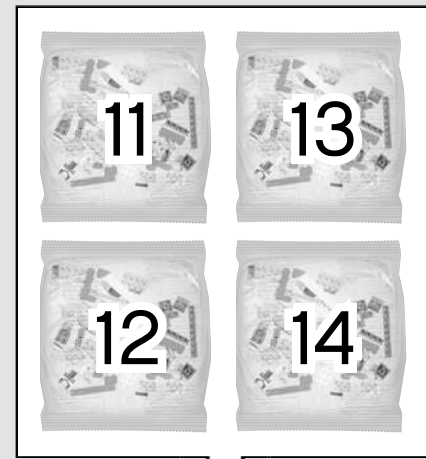
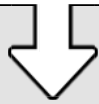
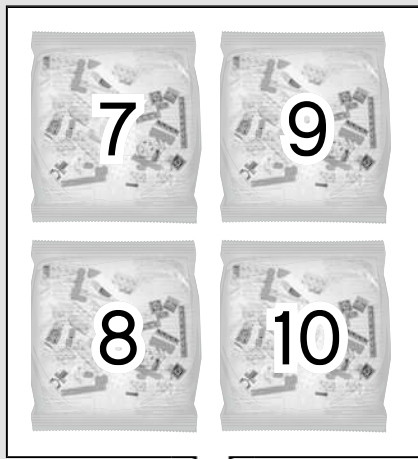

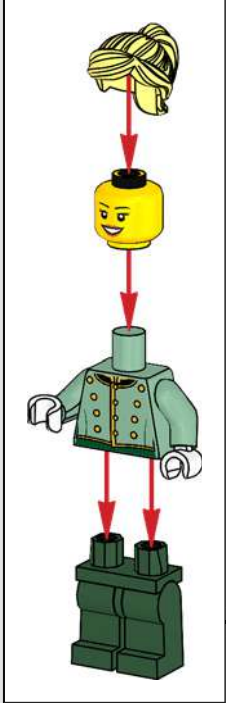
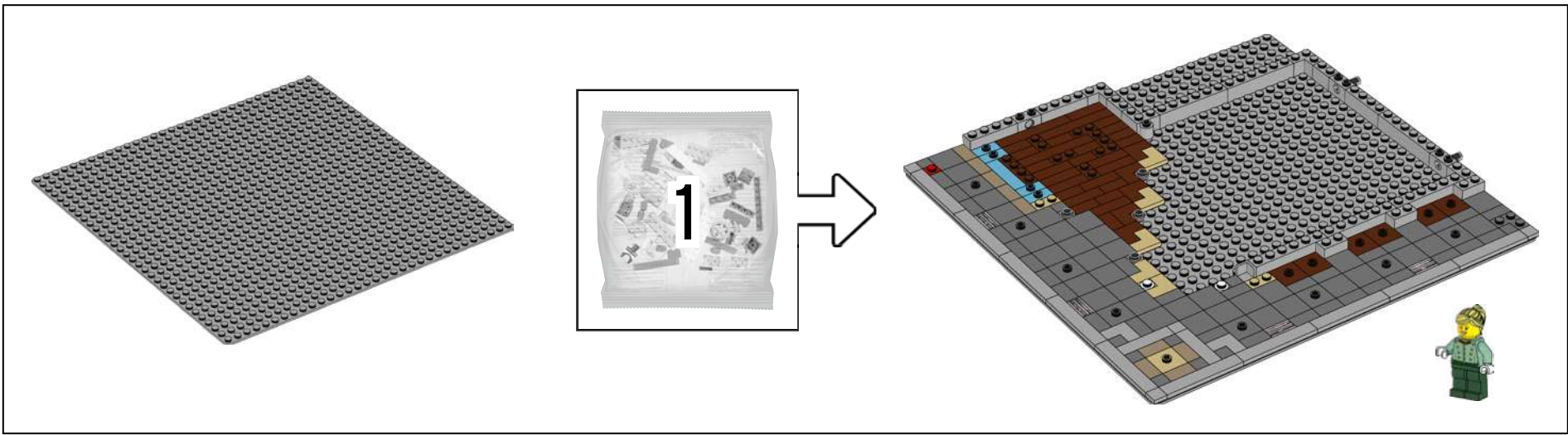

Looking for things to do during your stay?
Just ask the Receptionist about her favourite
shop within the 10211 Grand Emporium set,
or the best meal at Chez Albert.

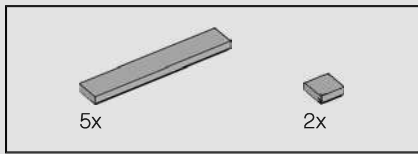

1

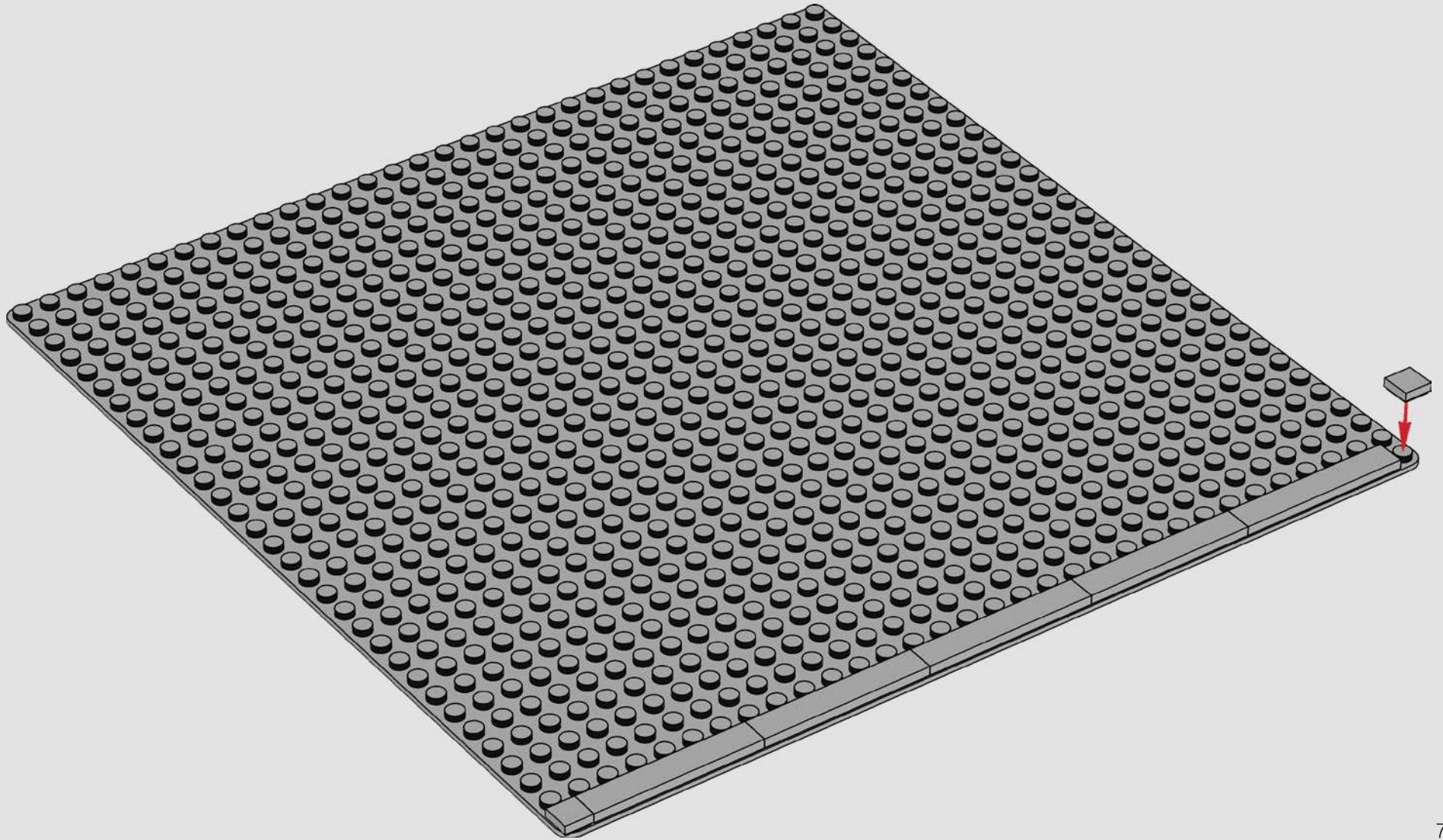

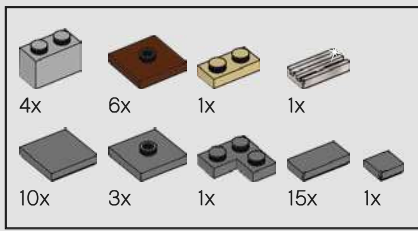

2

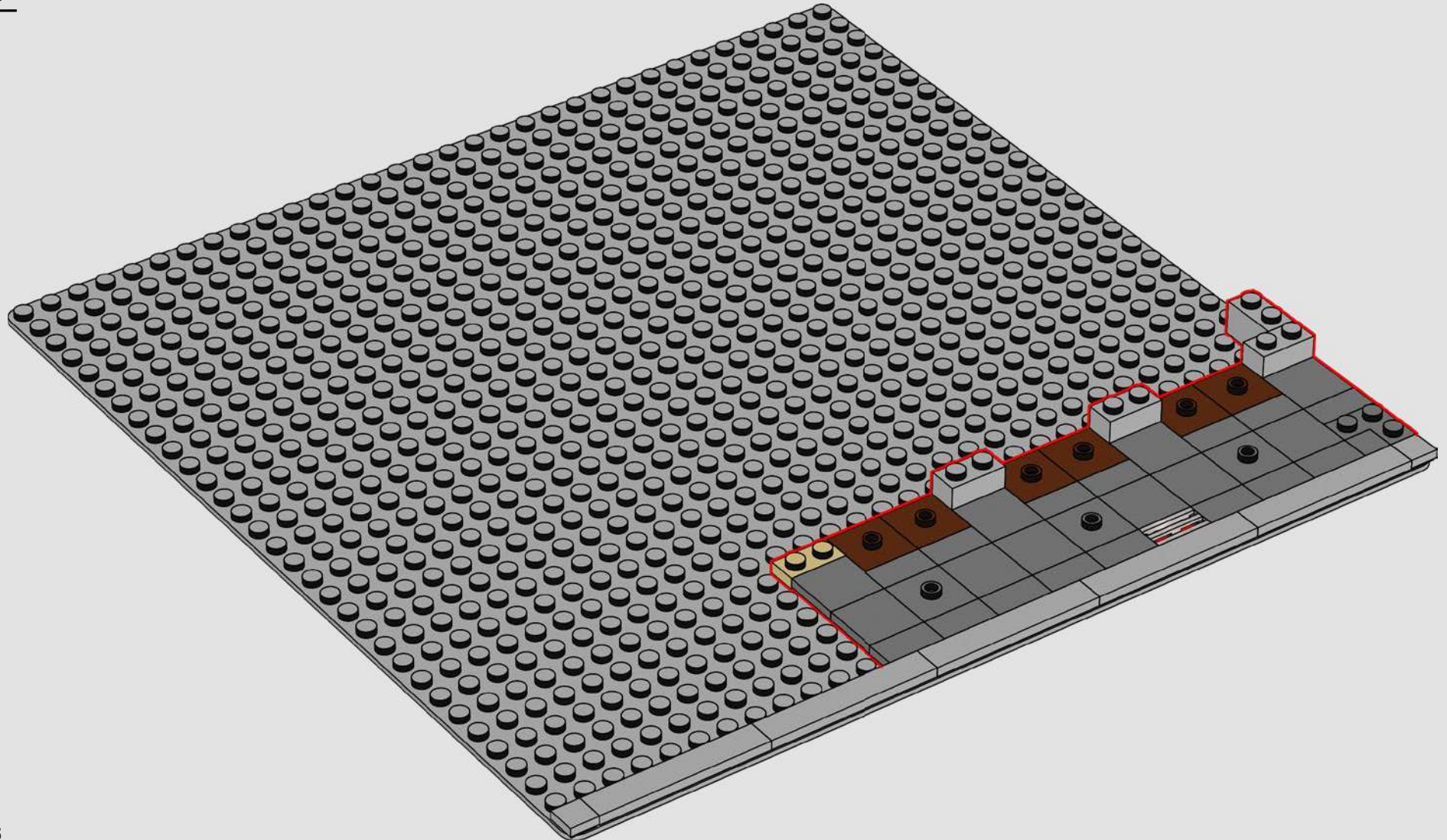

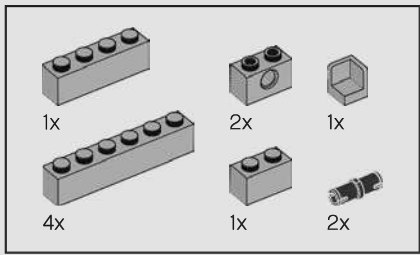

3

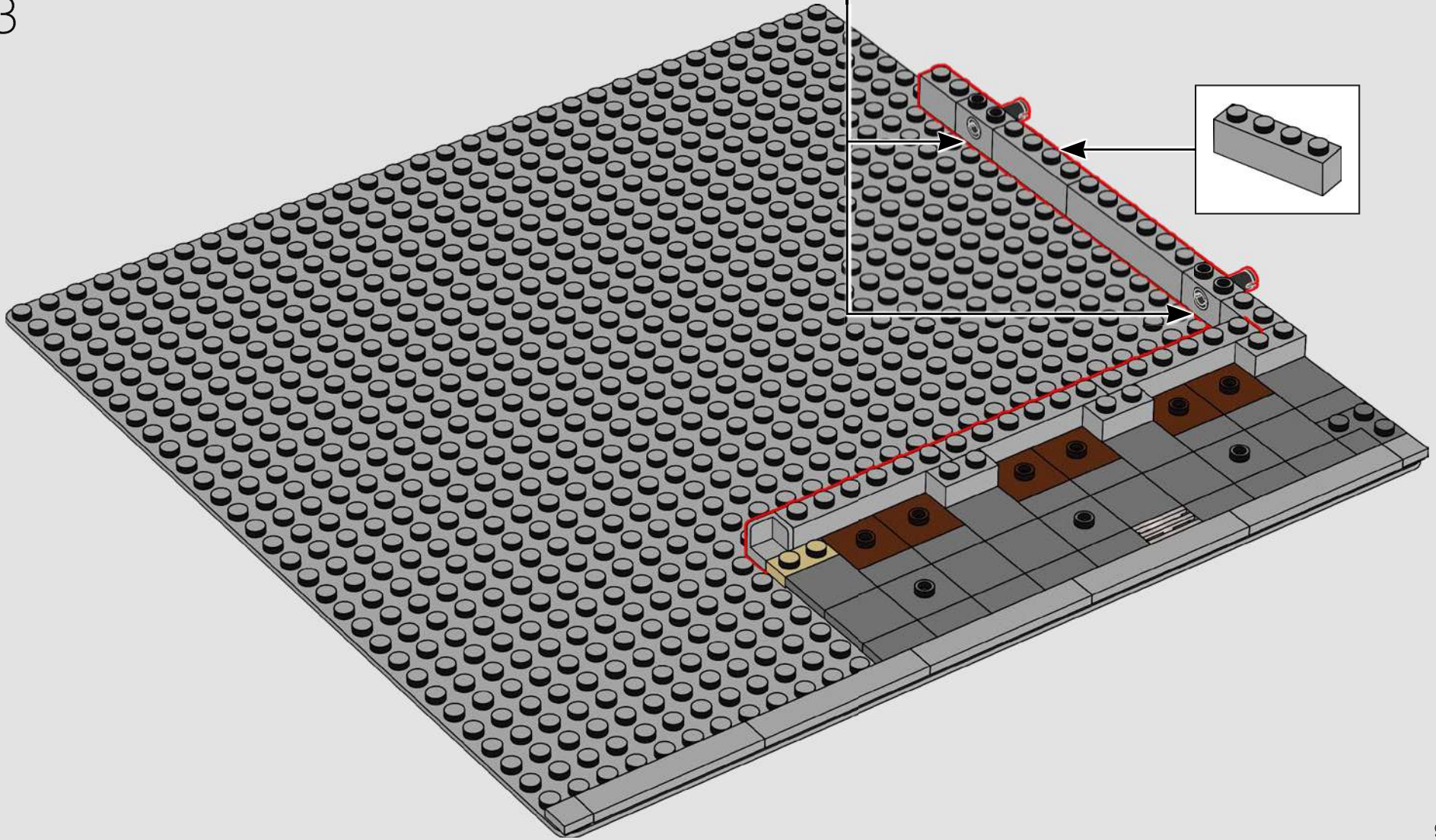
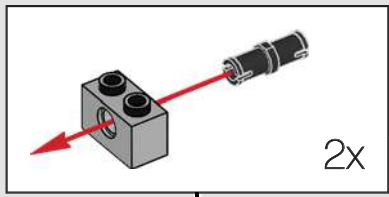

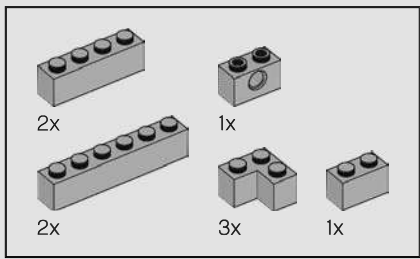

4

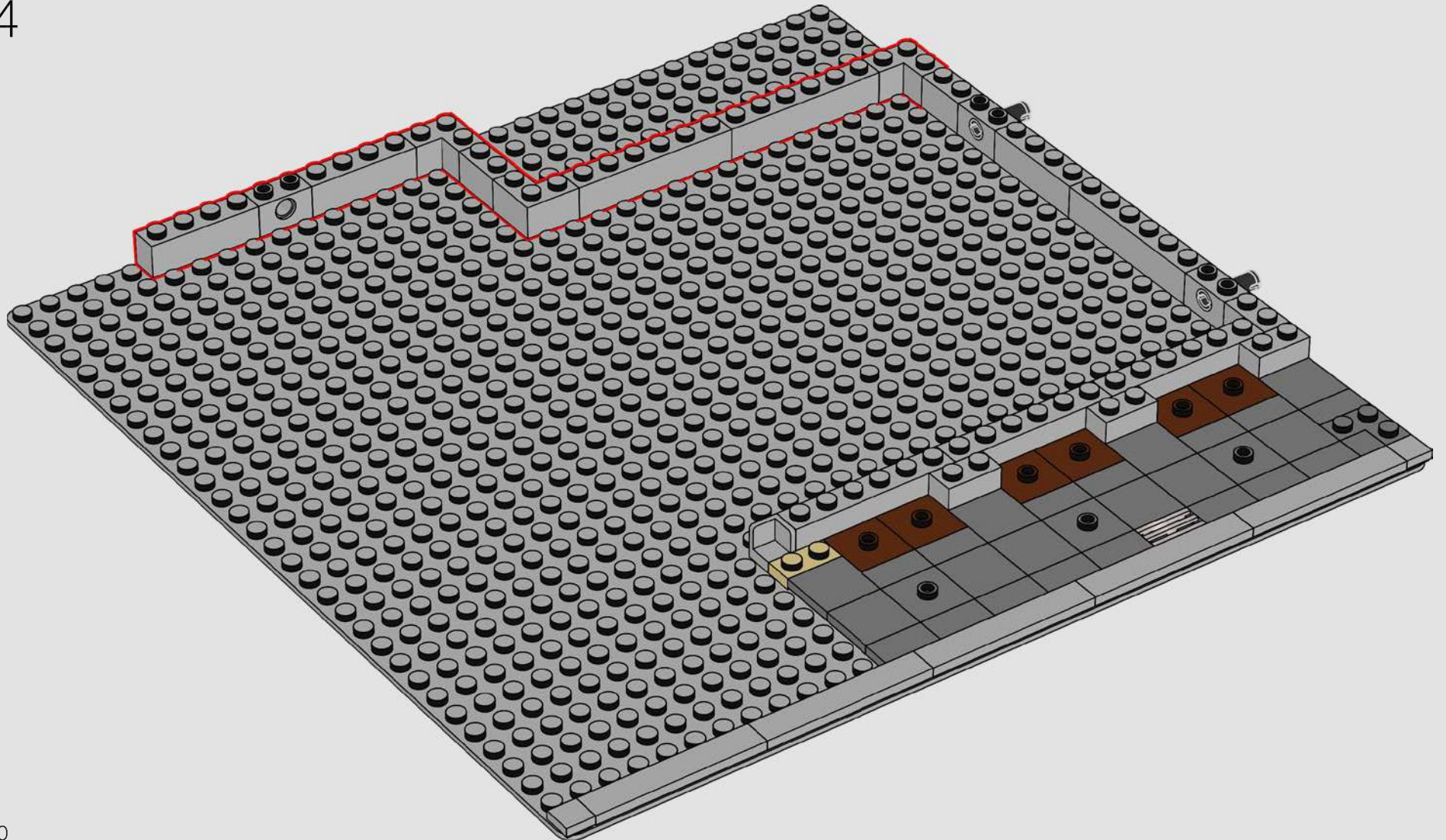

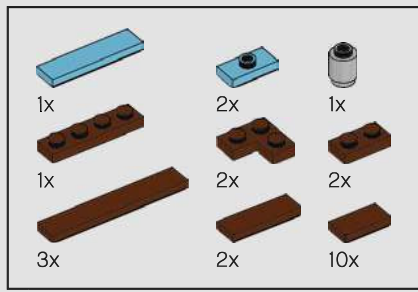

5

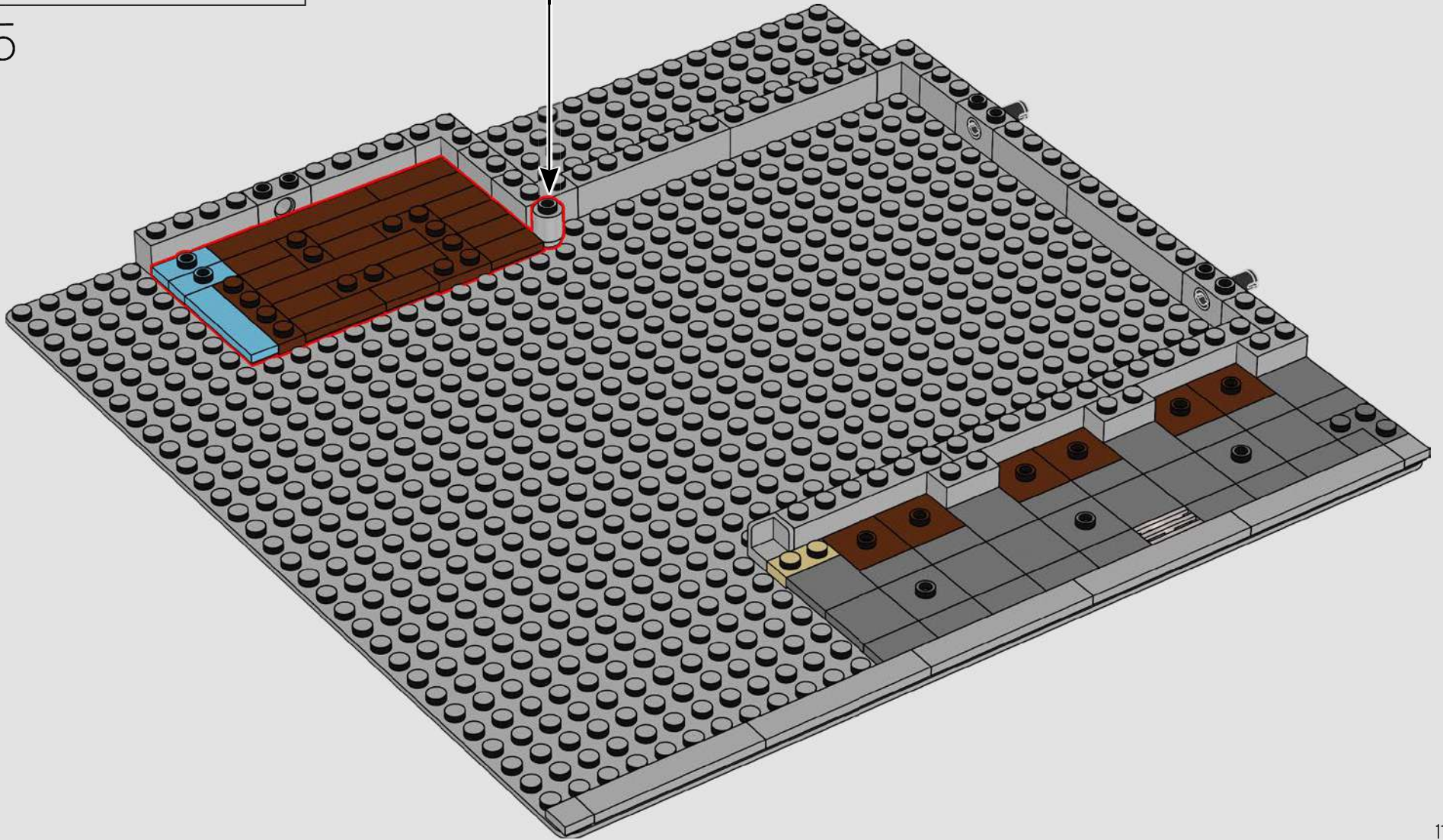
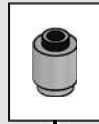

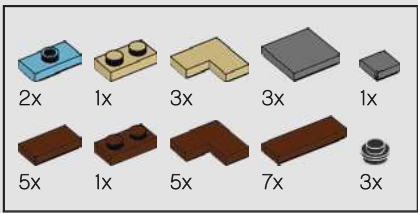

6

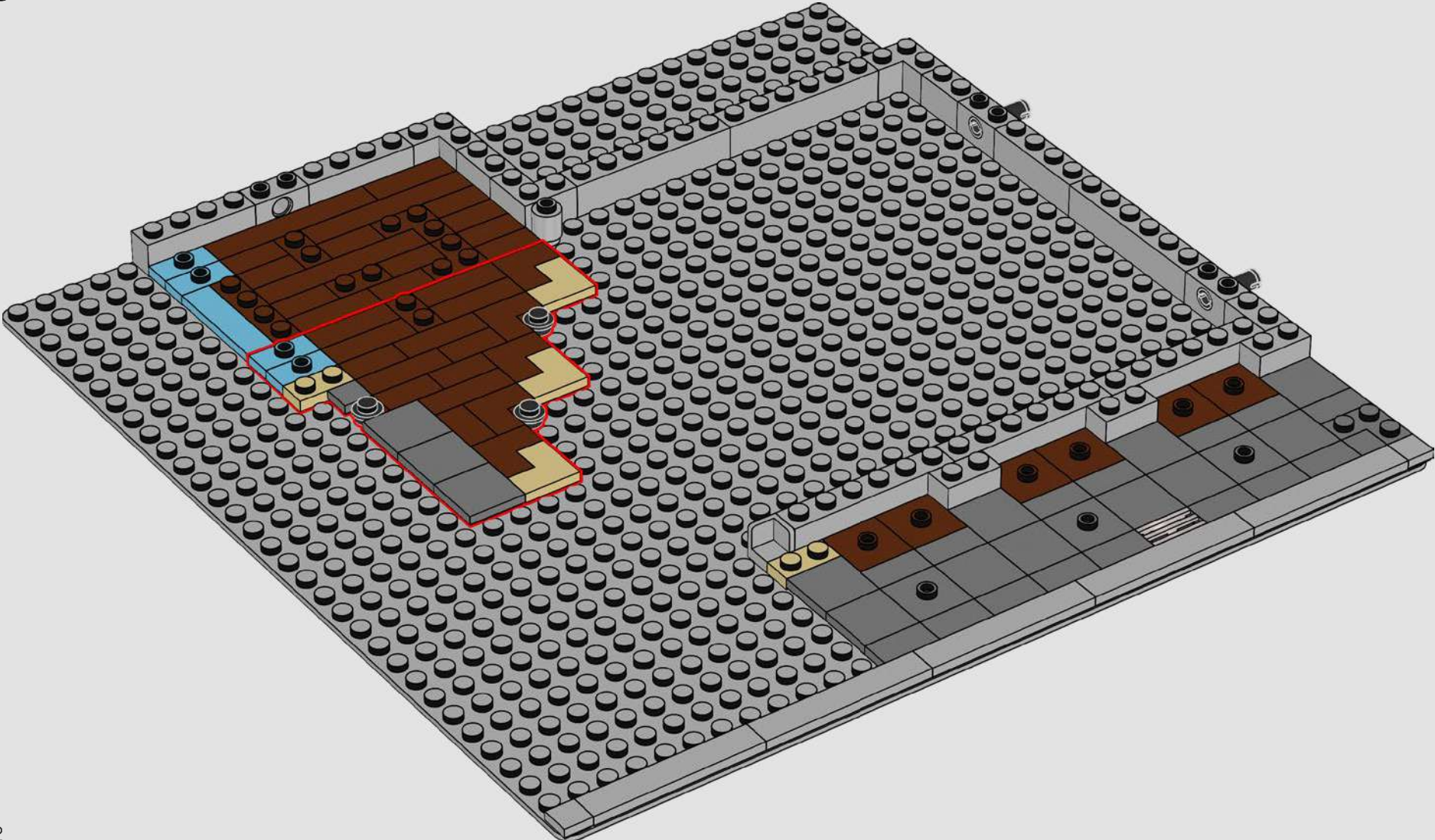

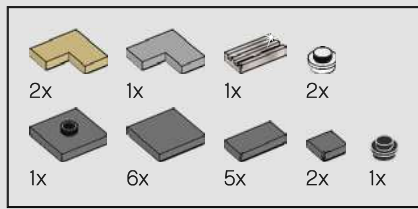

7

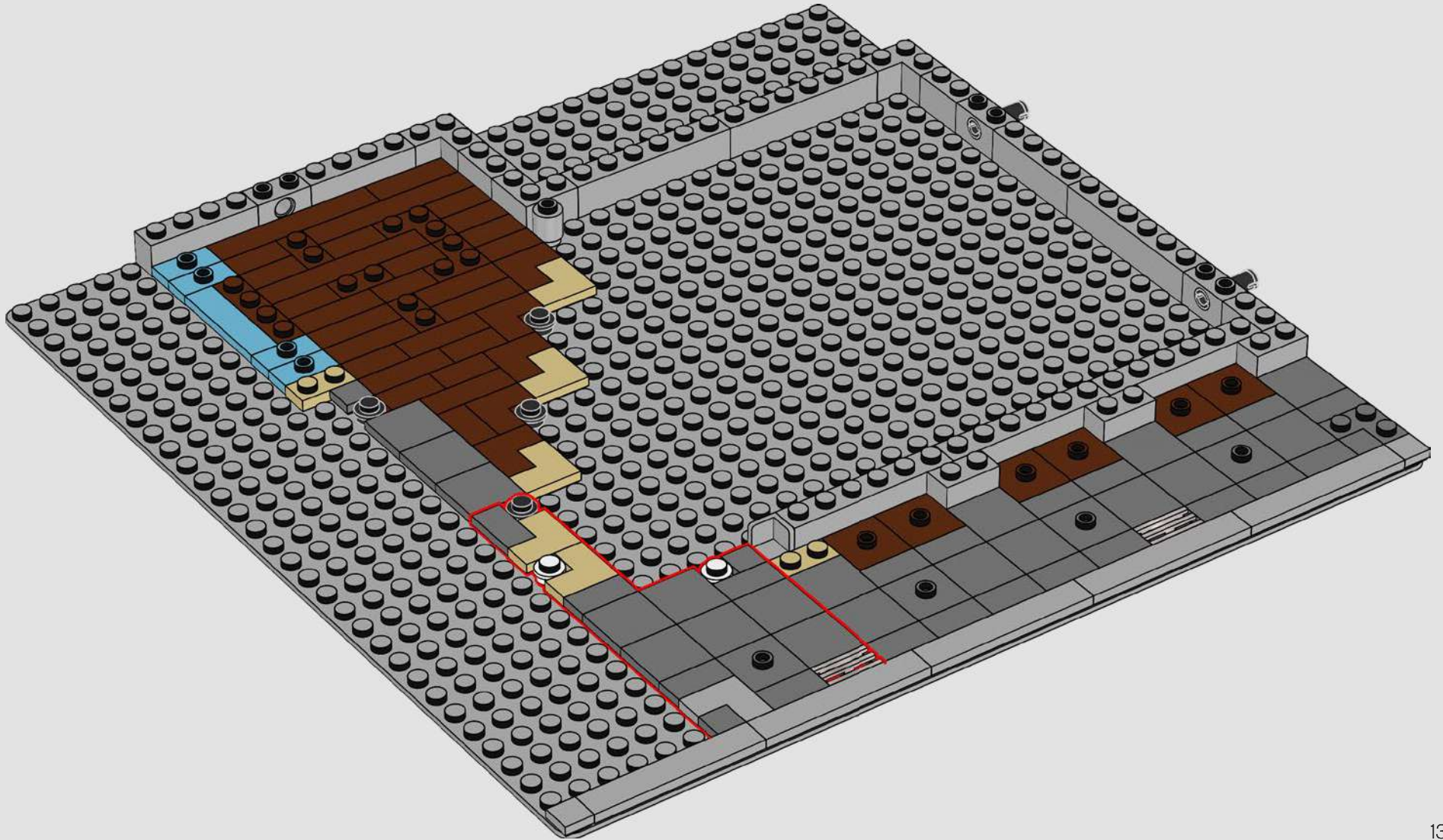

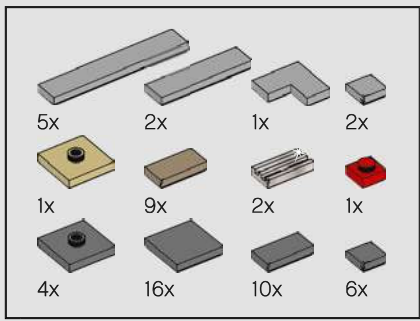

8

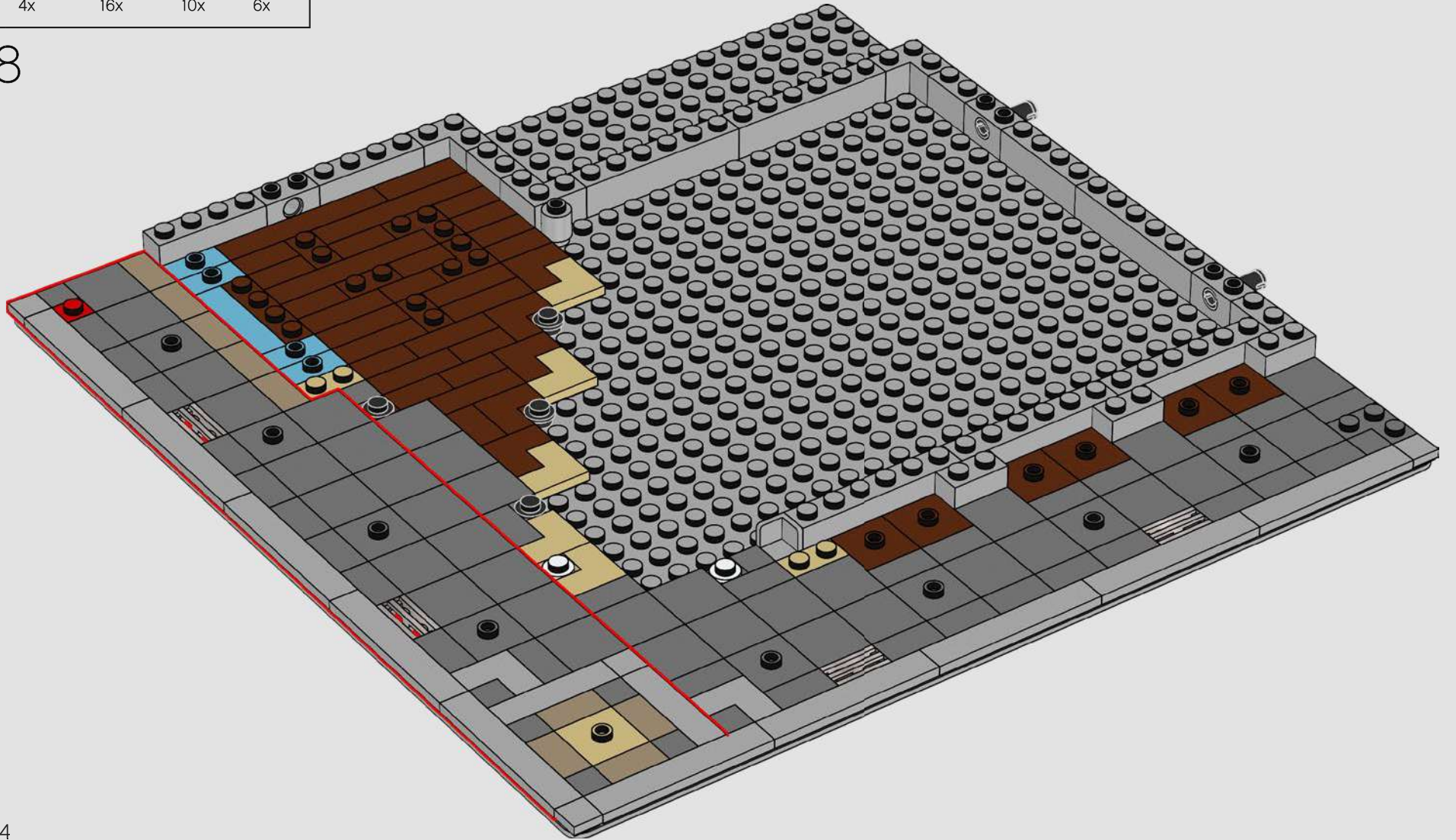

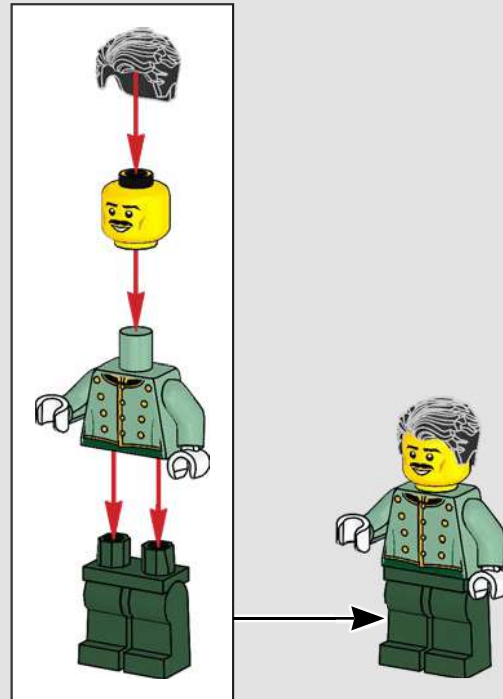
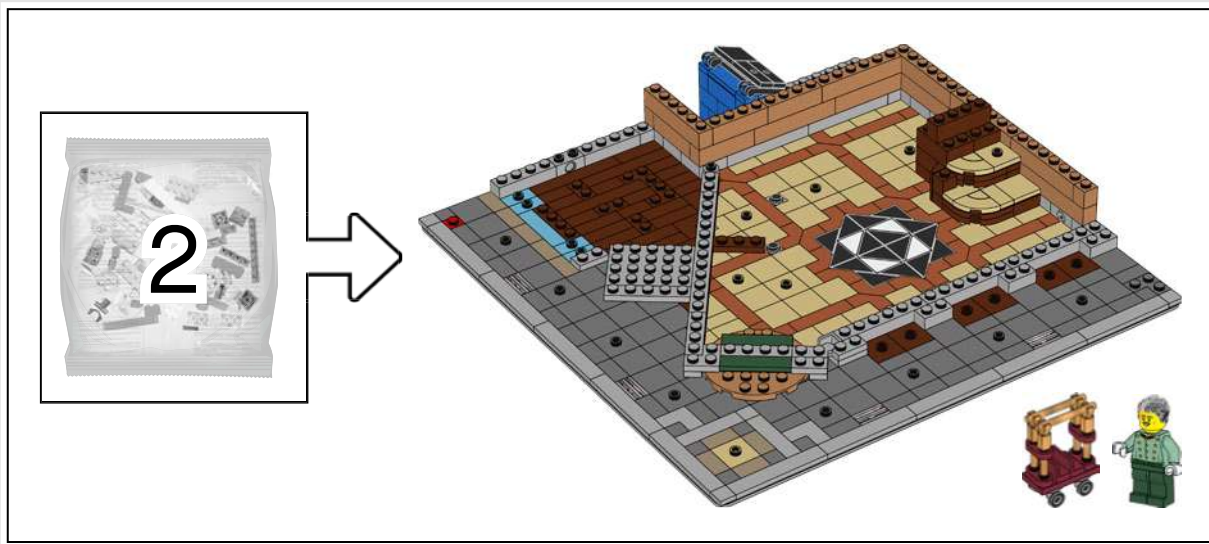

The Bellboy will happily help carry your luggage up the Hotel's stairs to your room.

Don't forget to give him a tip! 15

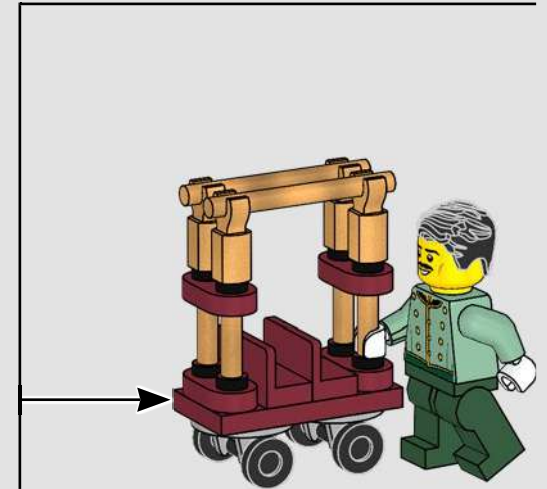
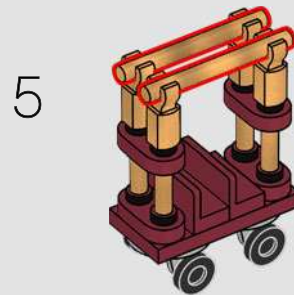
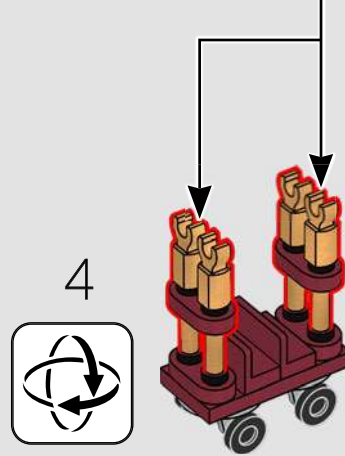
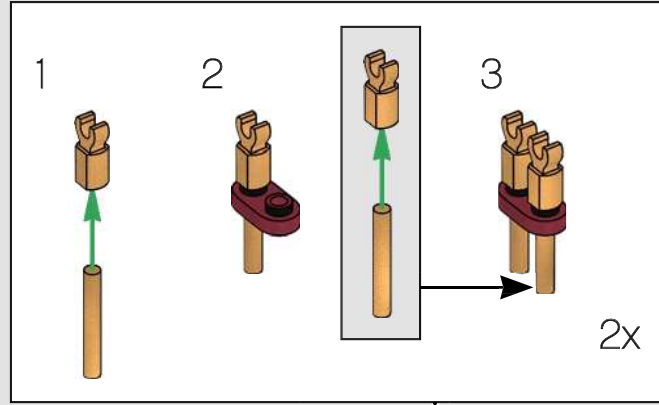
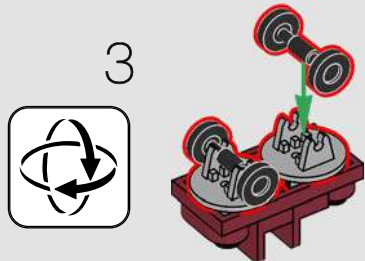
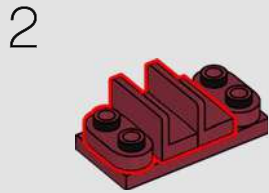
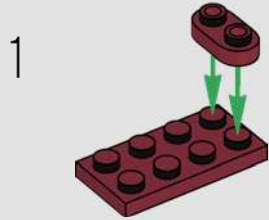
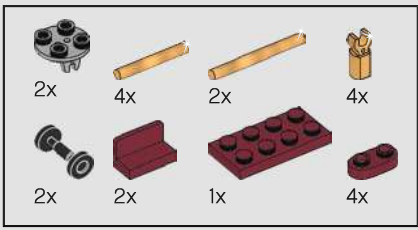

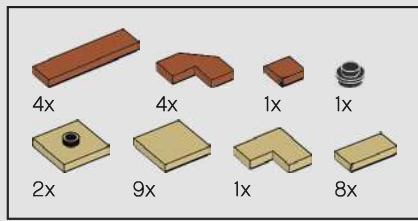

9

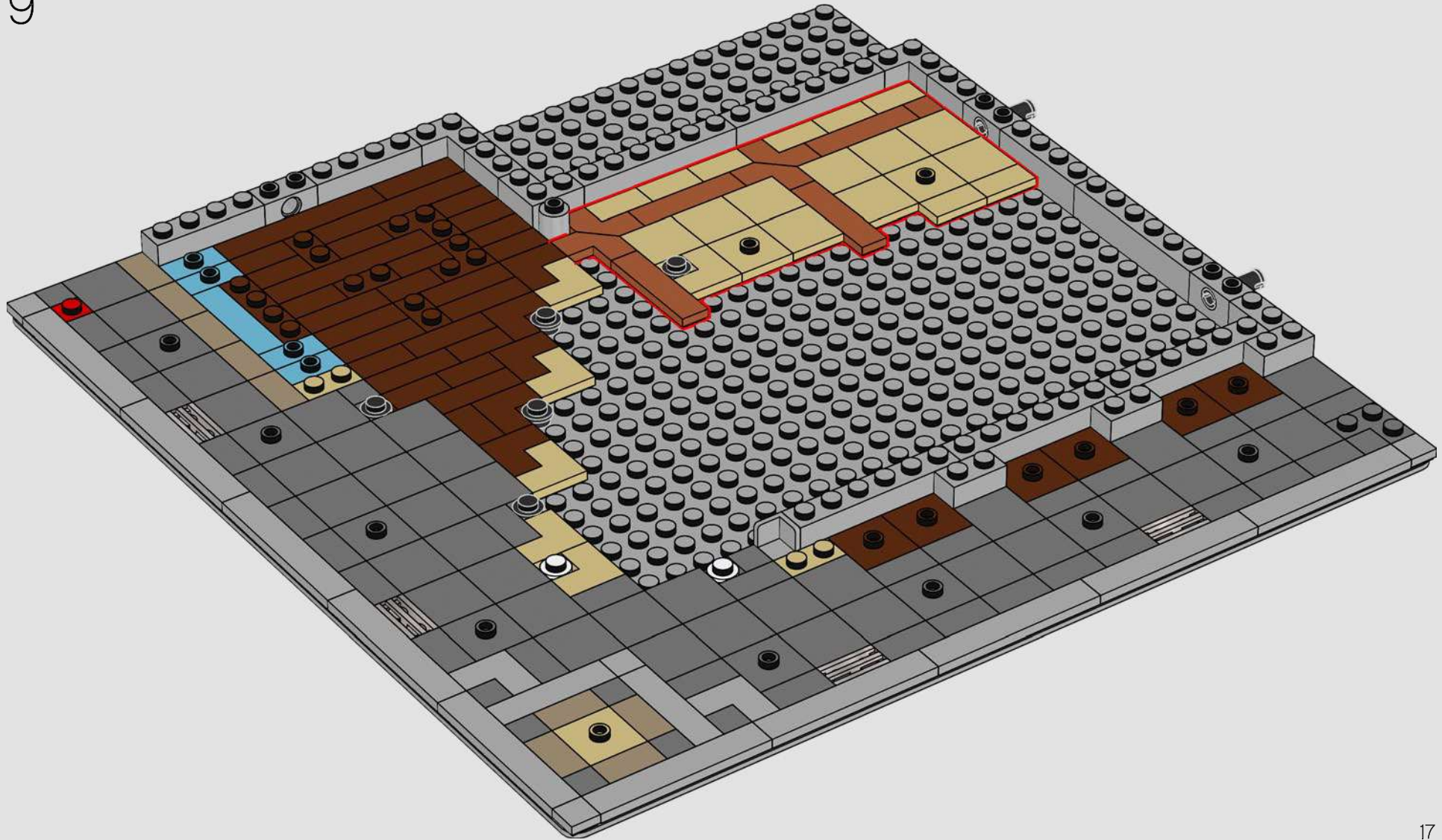

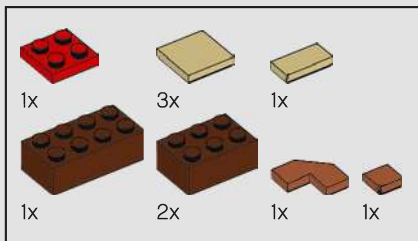

10

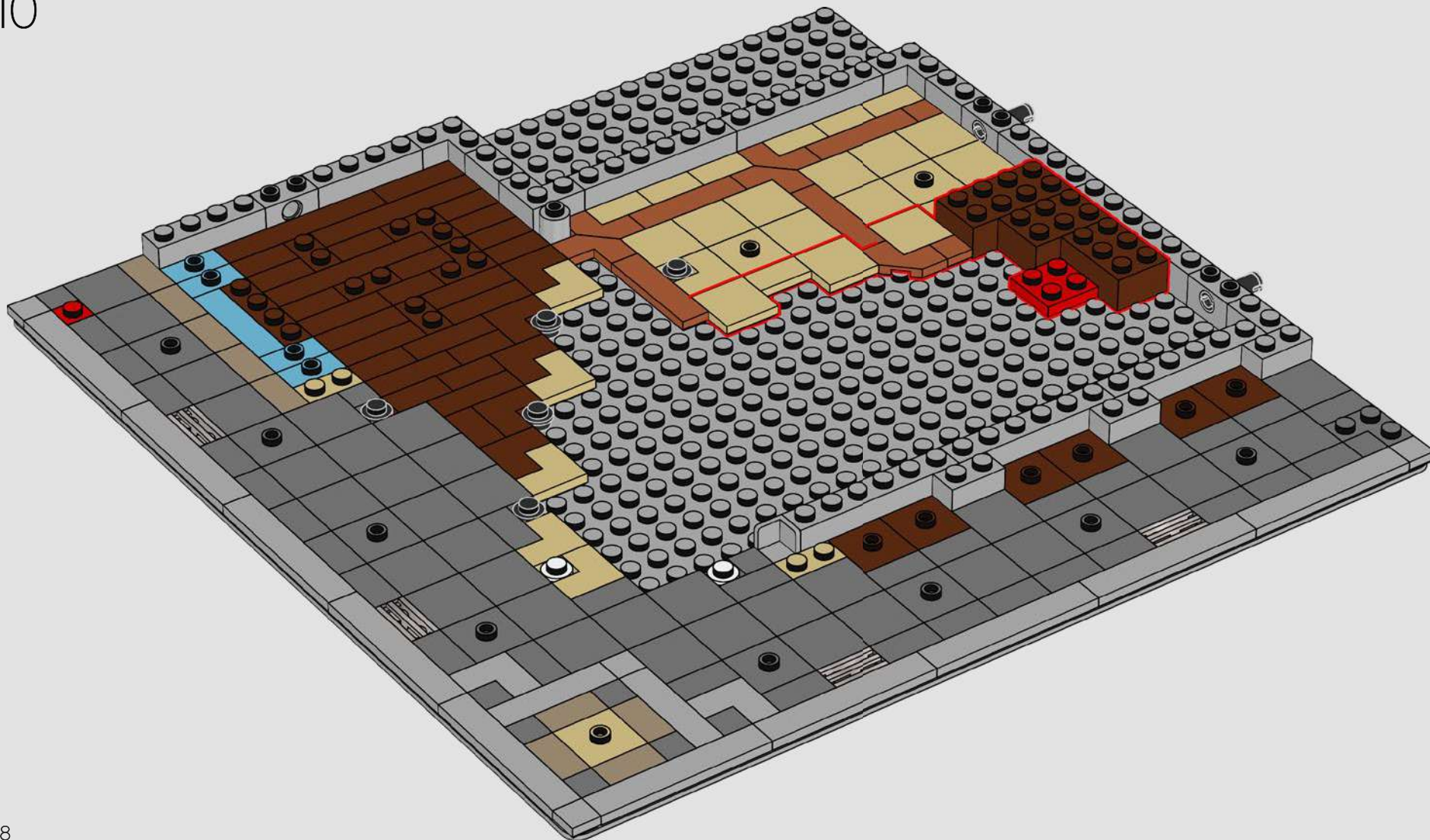

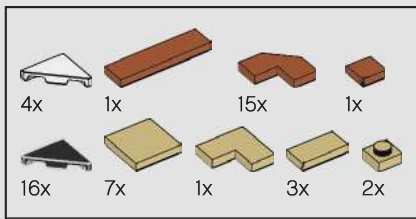

11

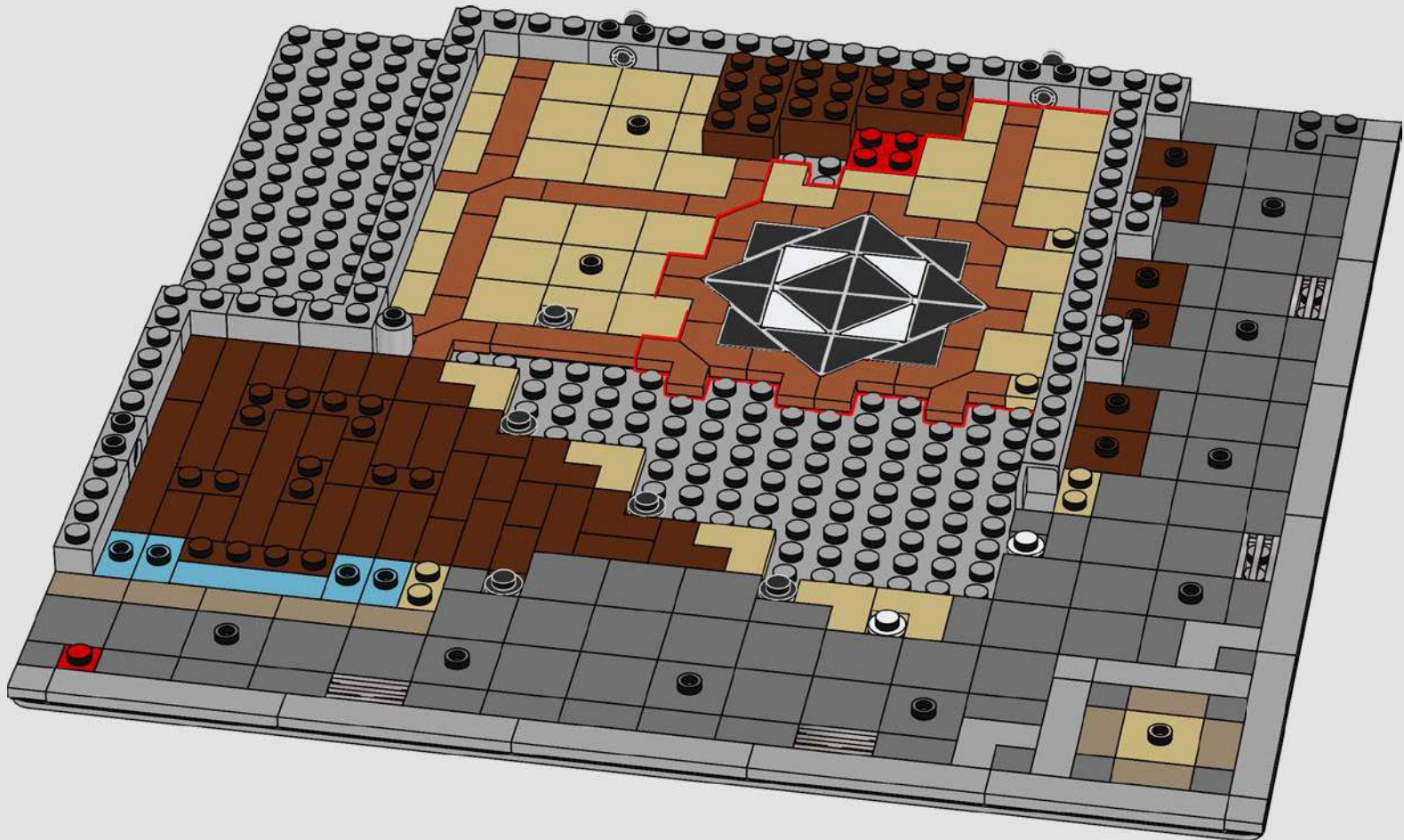

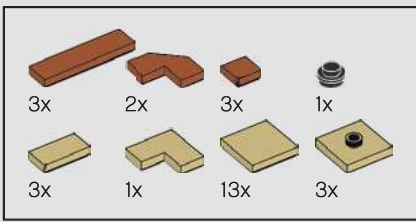

12

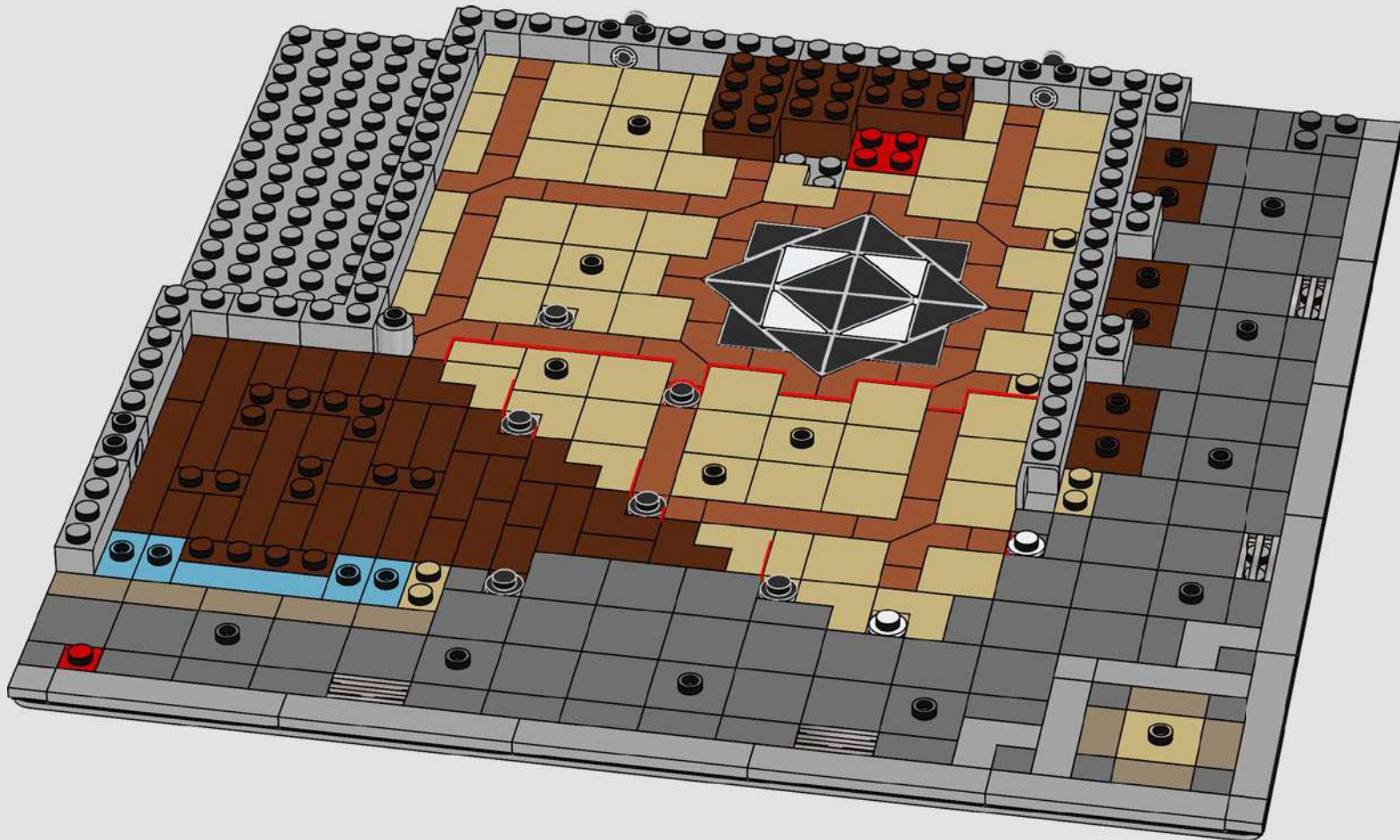

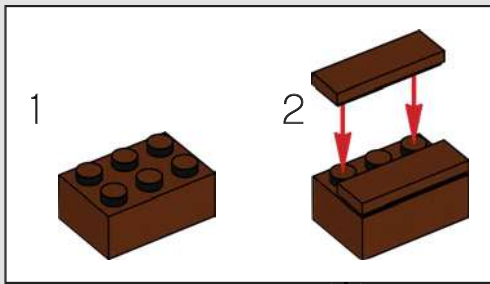
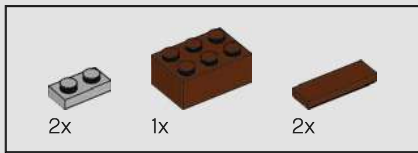

13

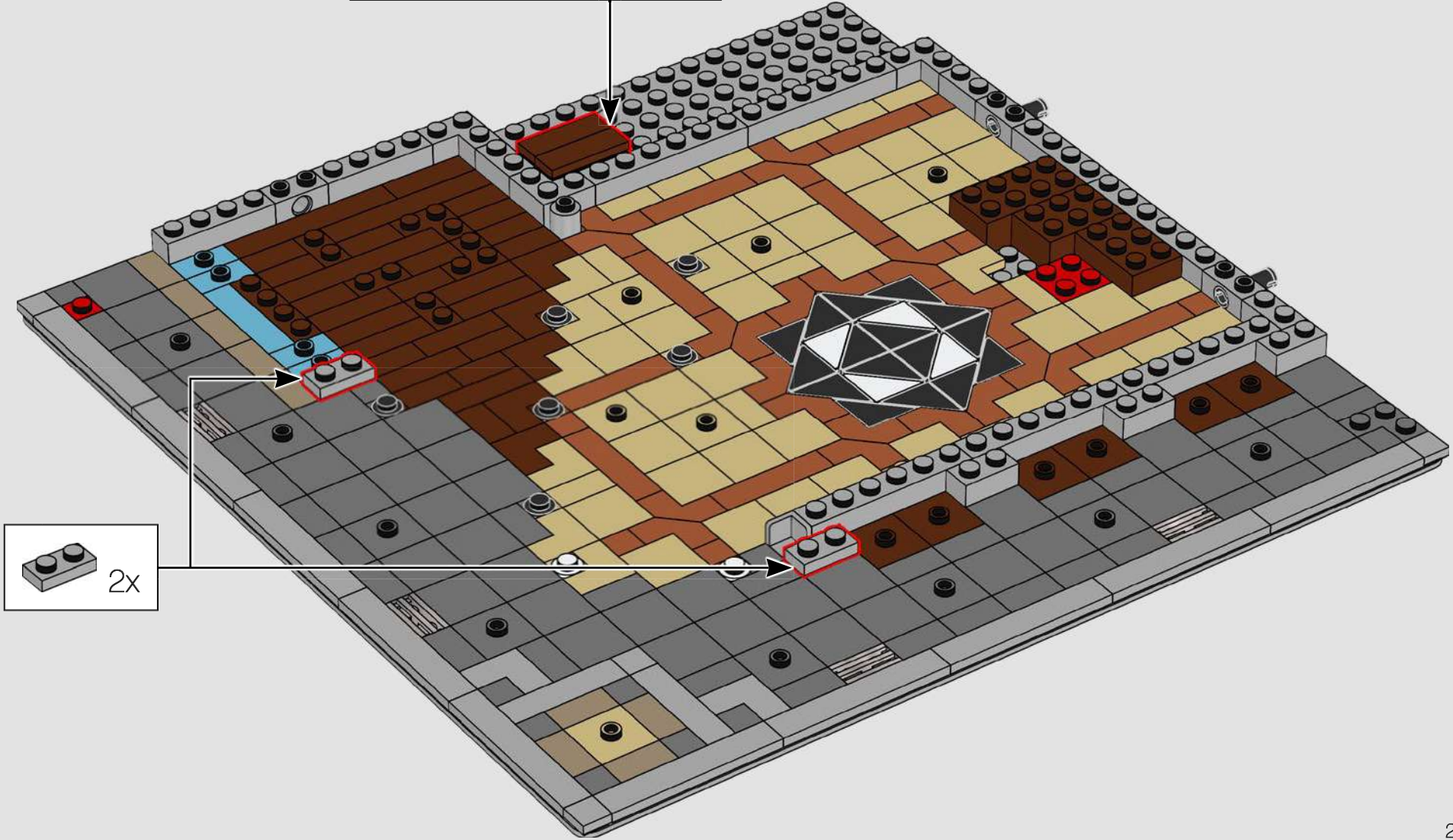

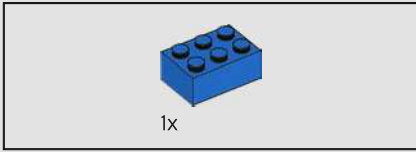
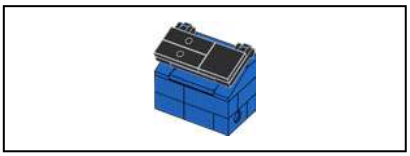

14

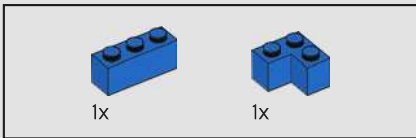
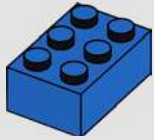

15

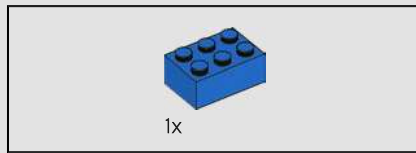
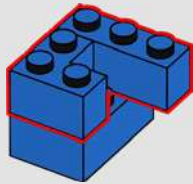

16

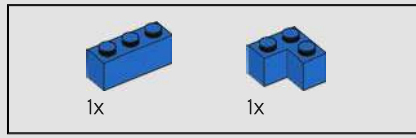
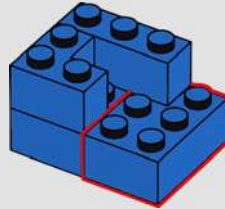

17

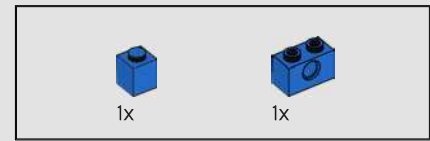
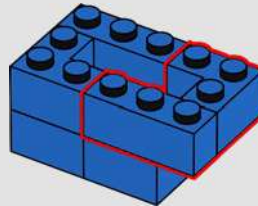

18

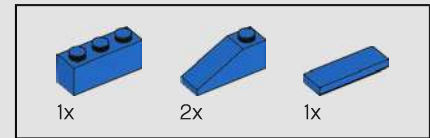
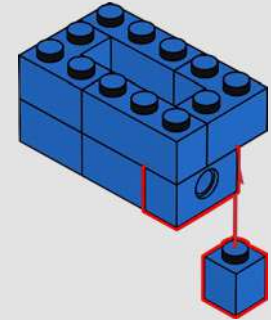

19

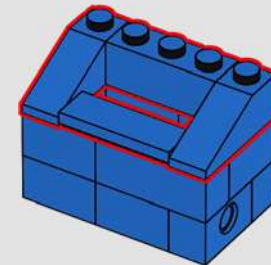

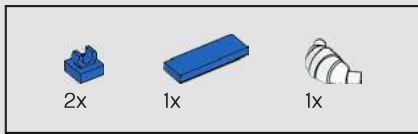

20

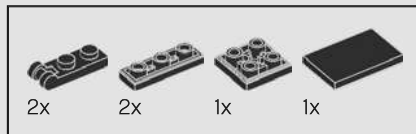
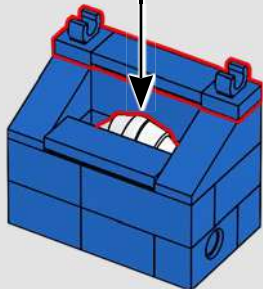

21

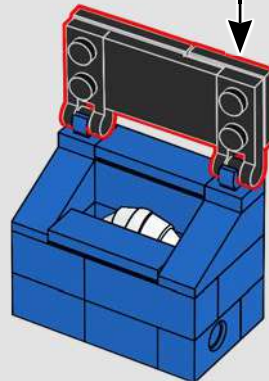
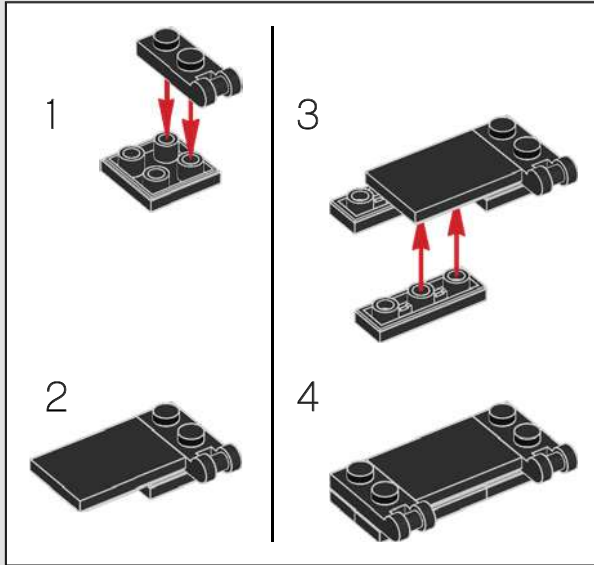

22

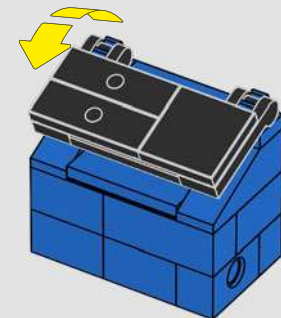

This croissant was found at the Parisian Restaurant in the 10243 set ... but why would anyone want a mouldy white croissant?

23

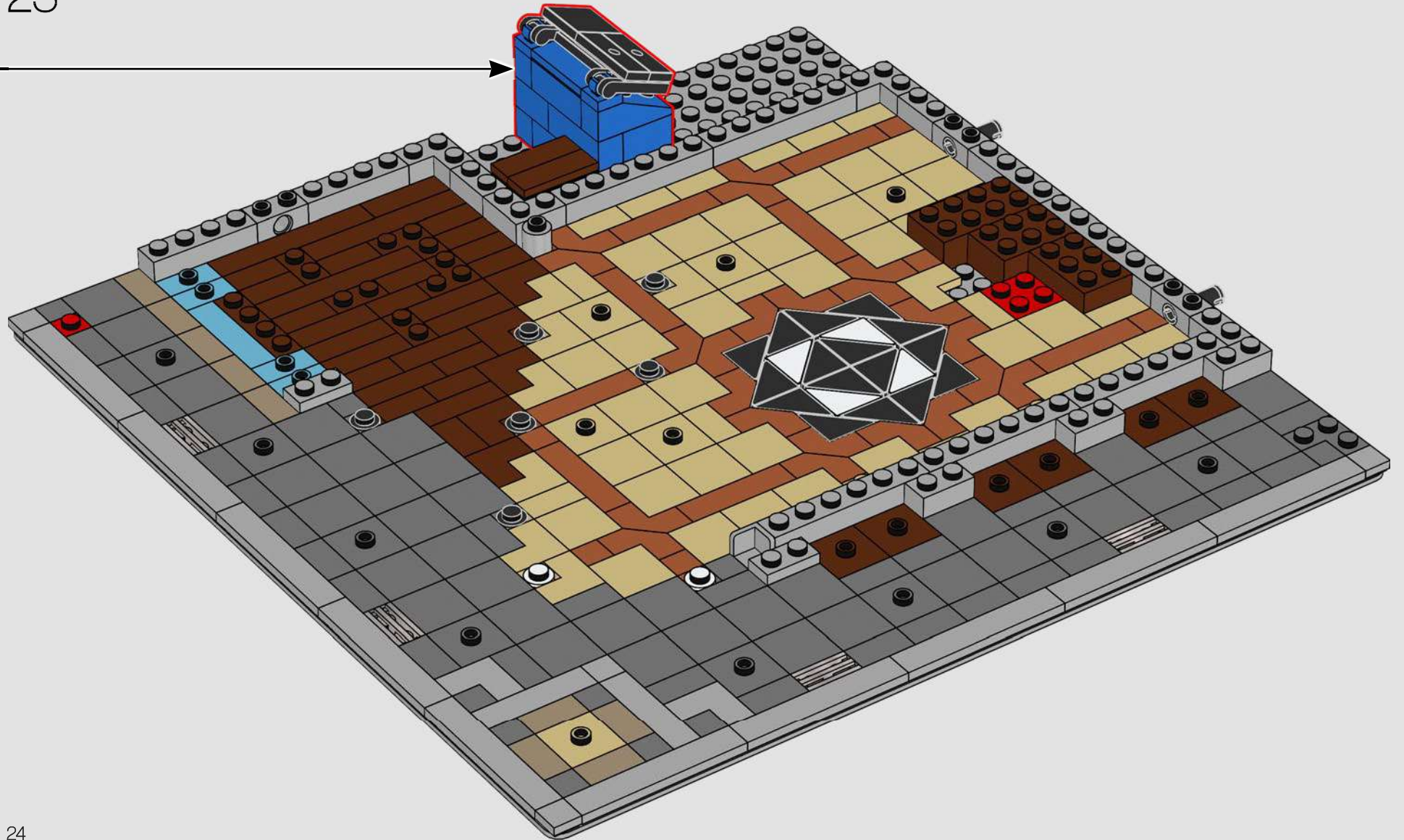

24

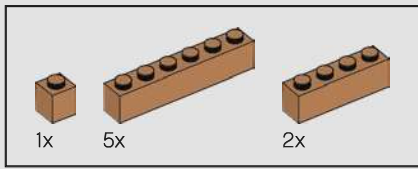

24

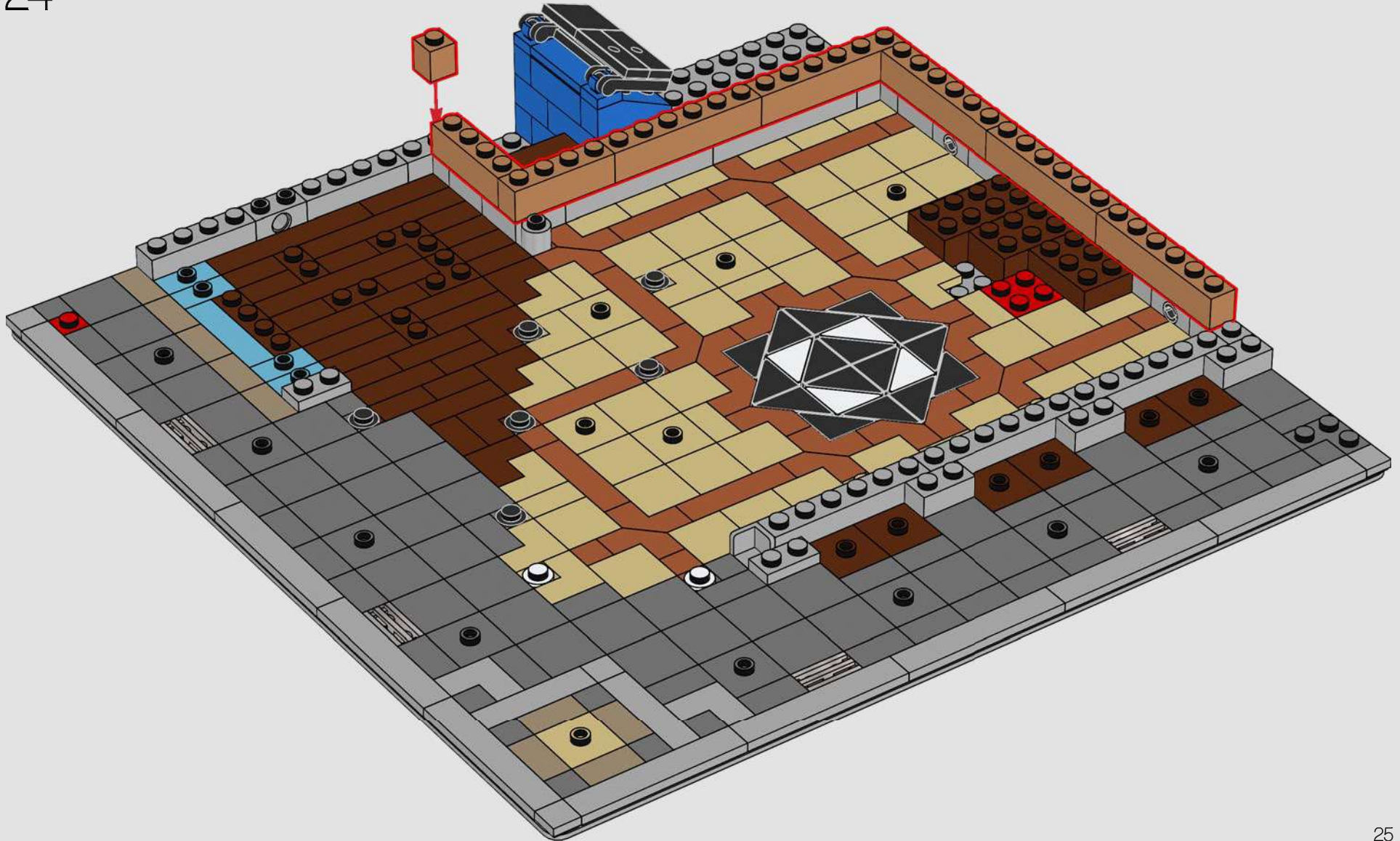

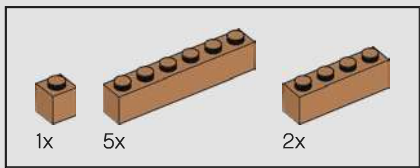

25

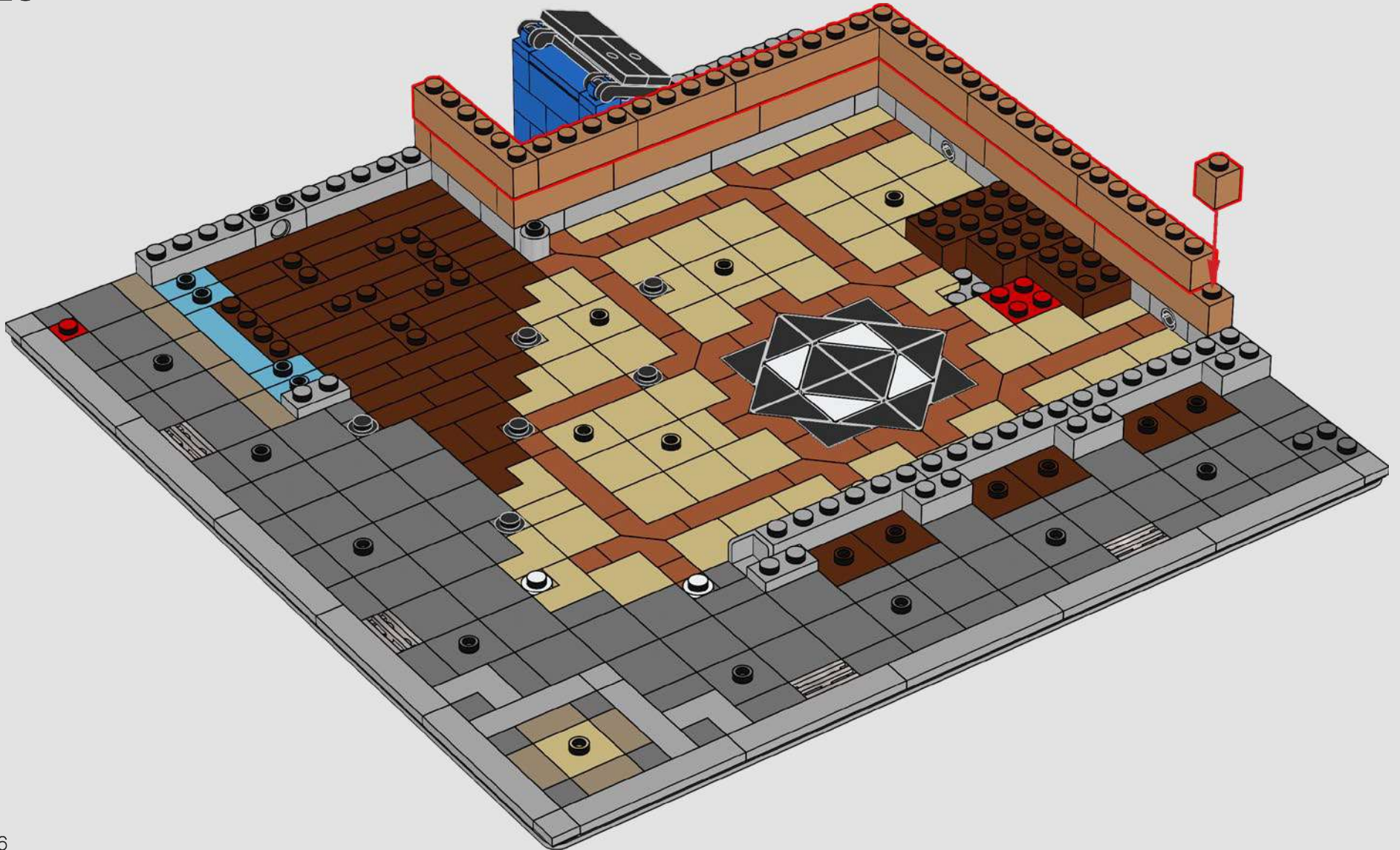

26

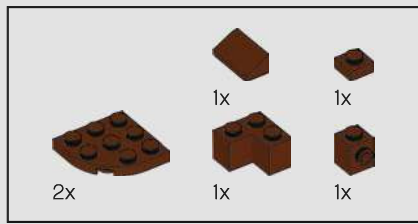

26

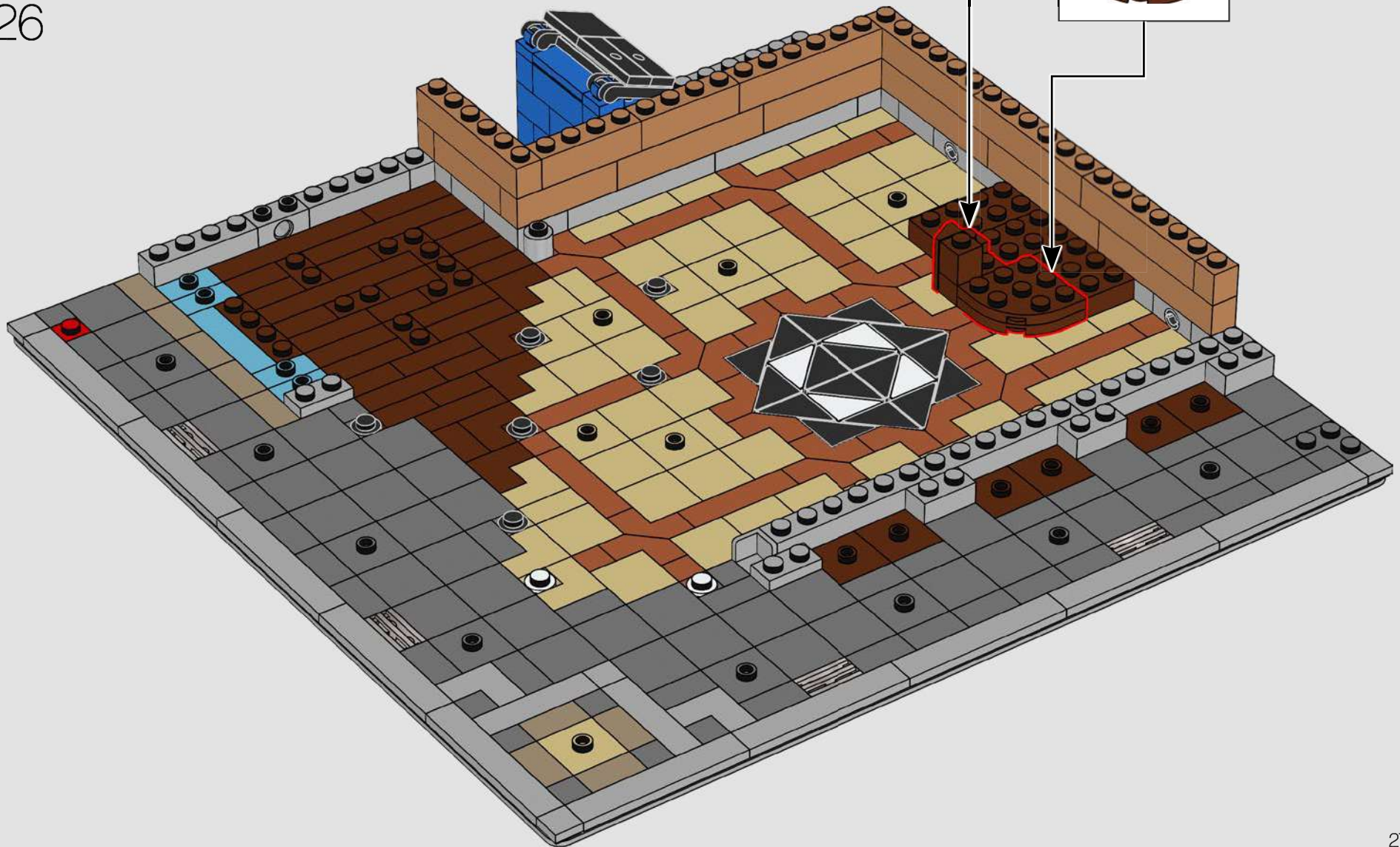
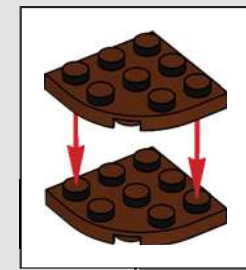
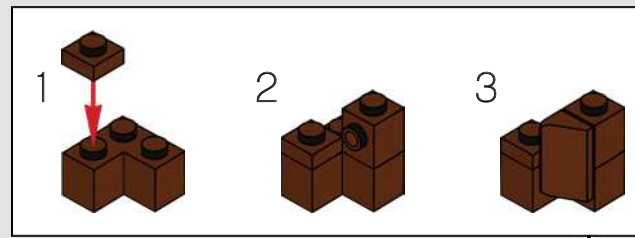

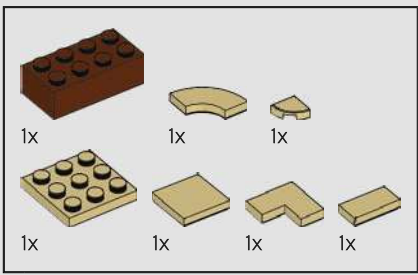

27

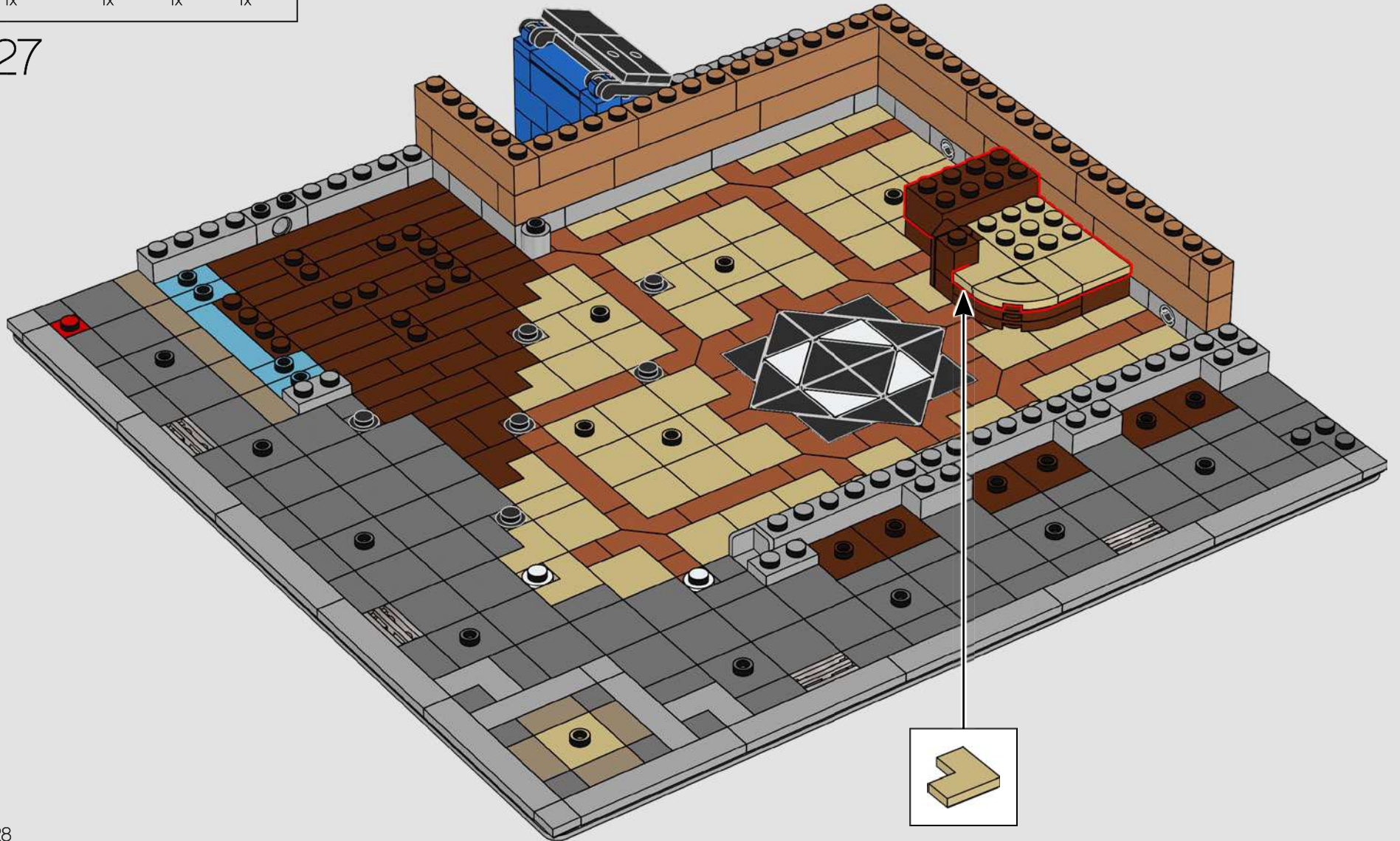

28



28

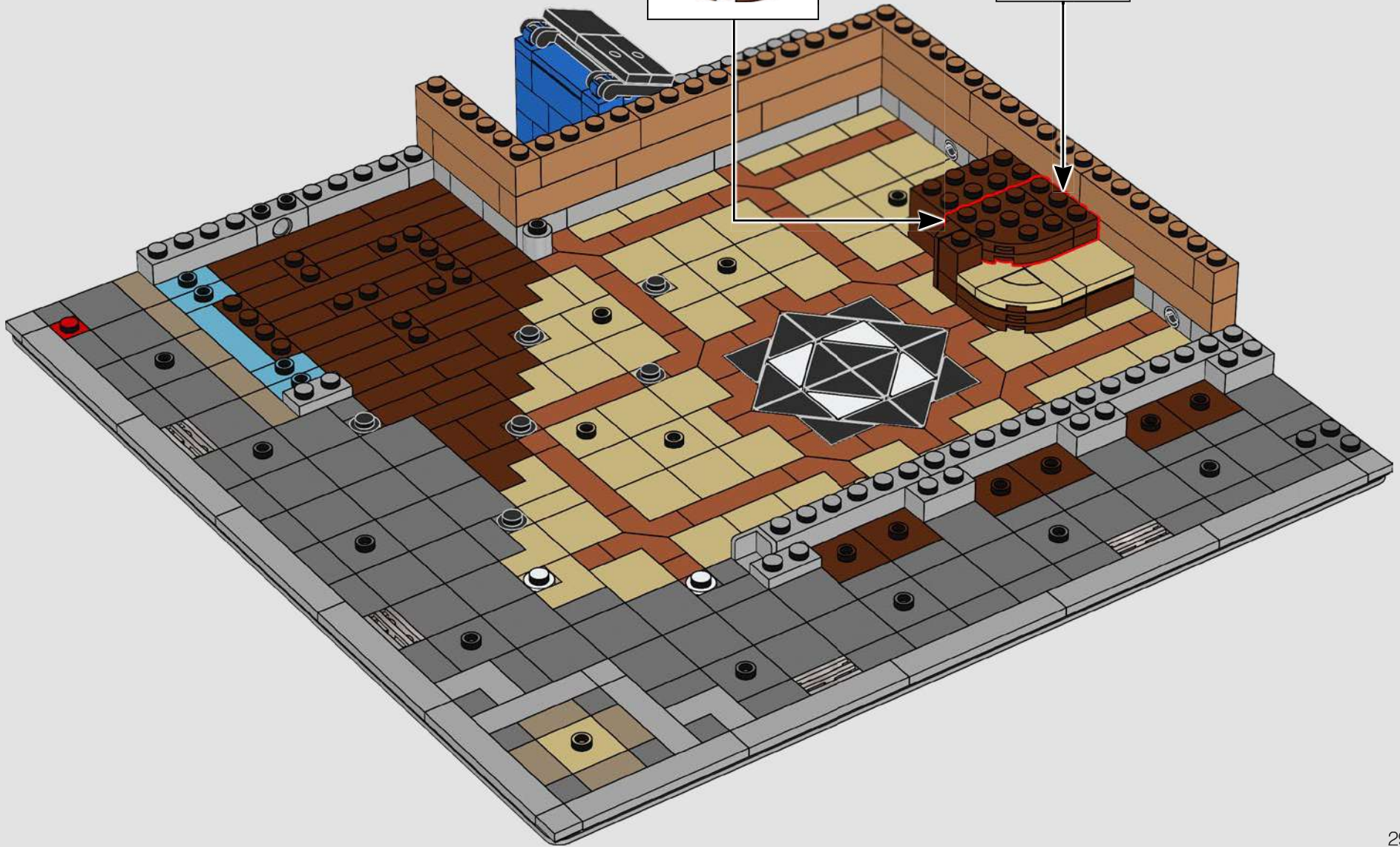
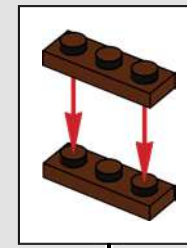
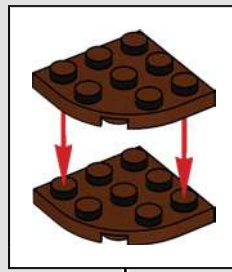

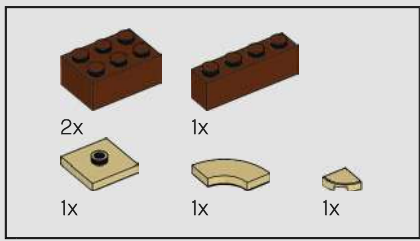

29

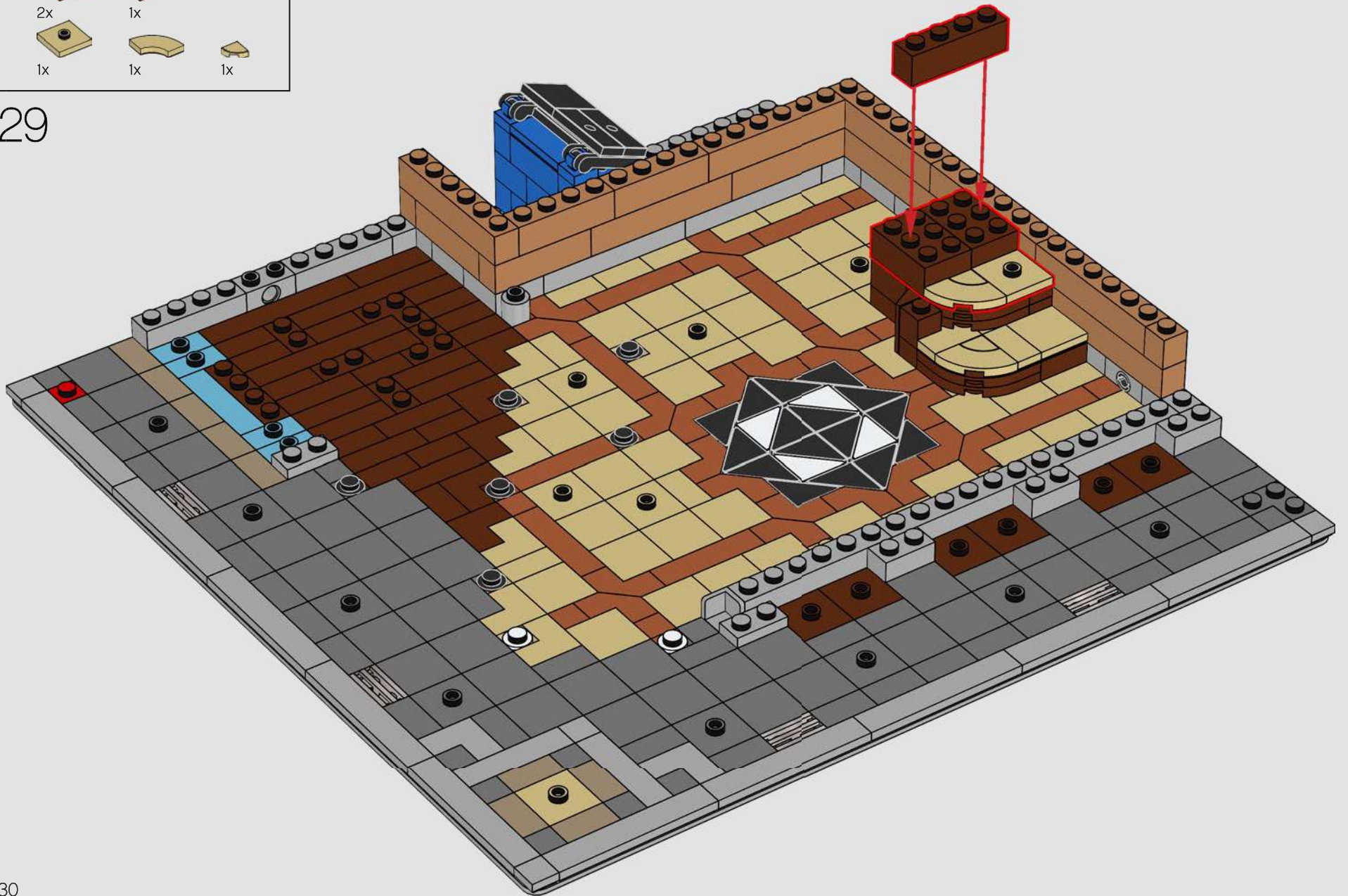

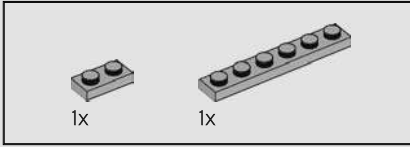
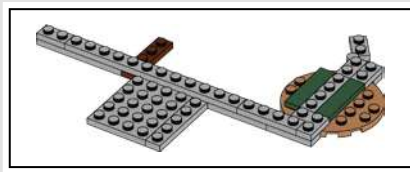

30

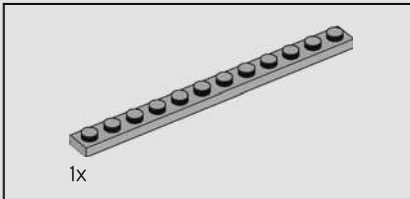
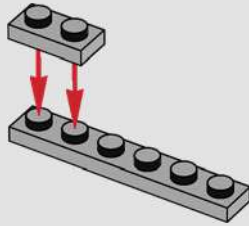

31

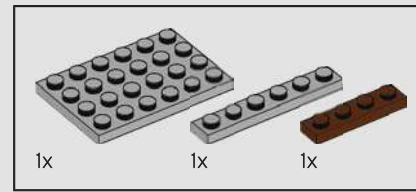
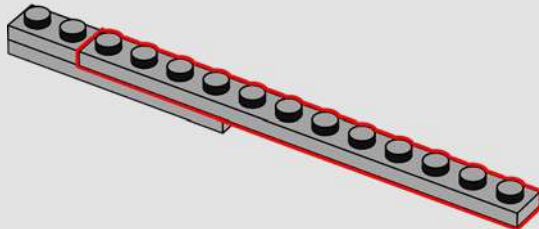

32

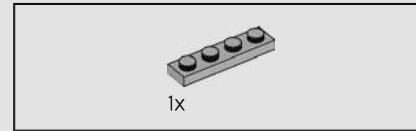
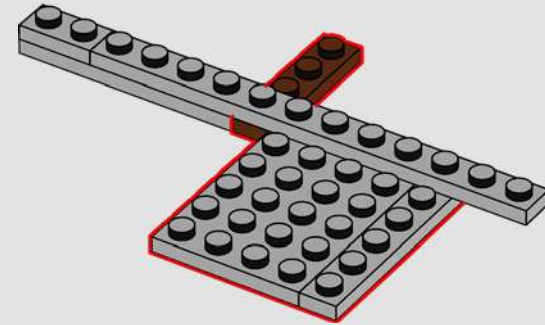

33

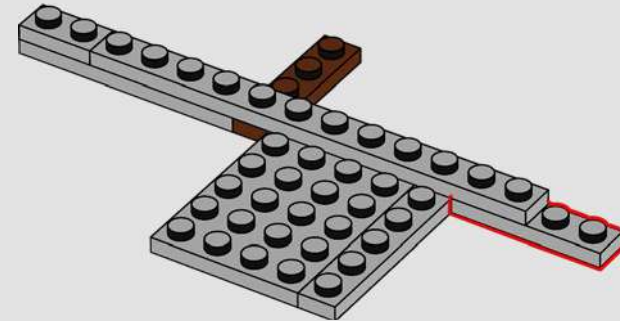

36

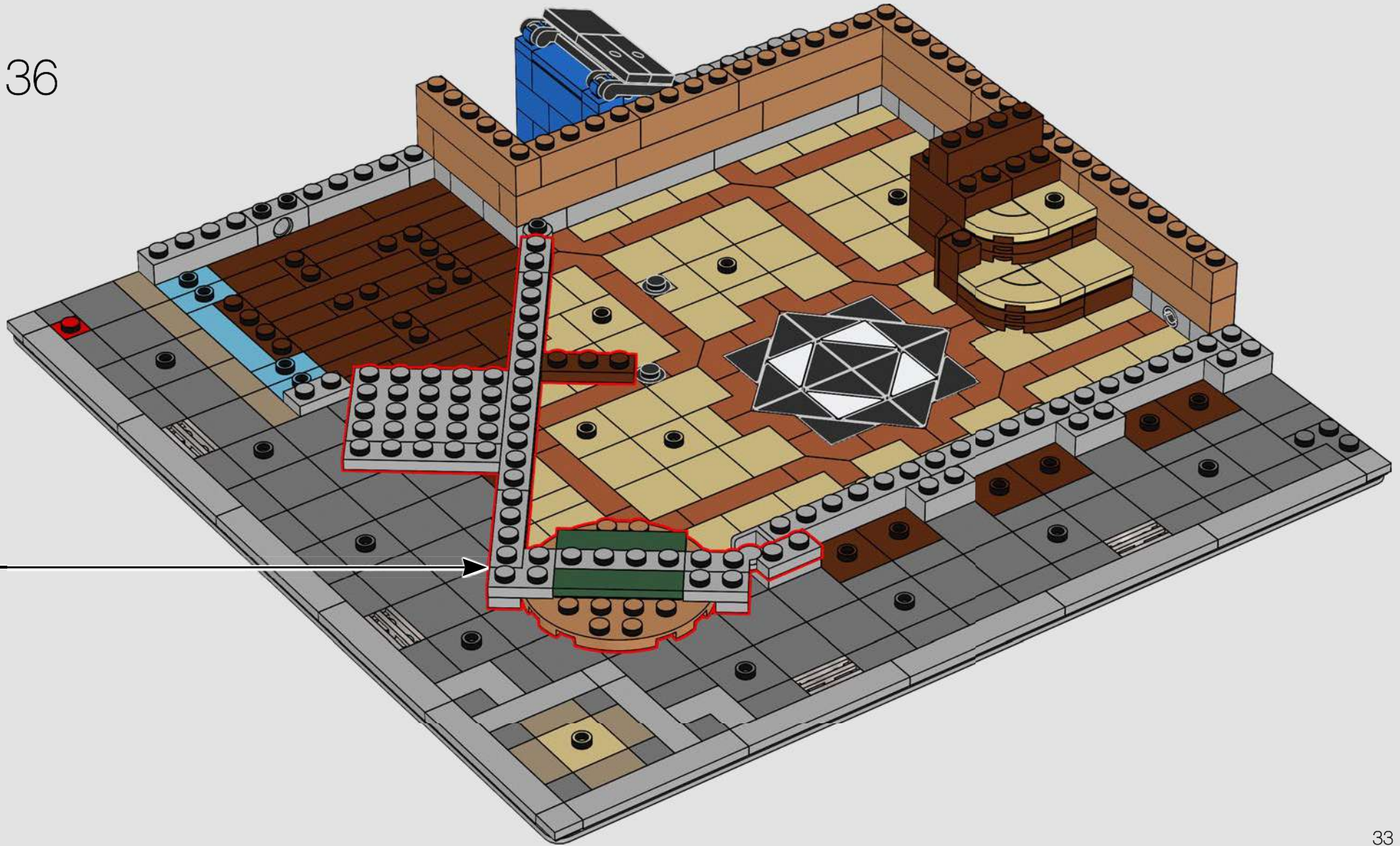

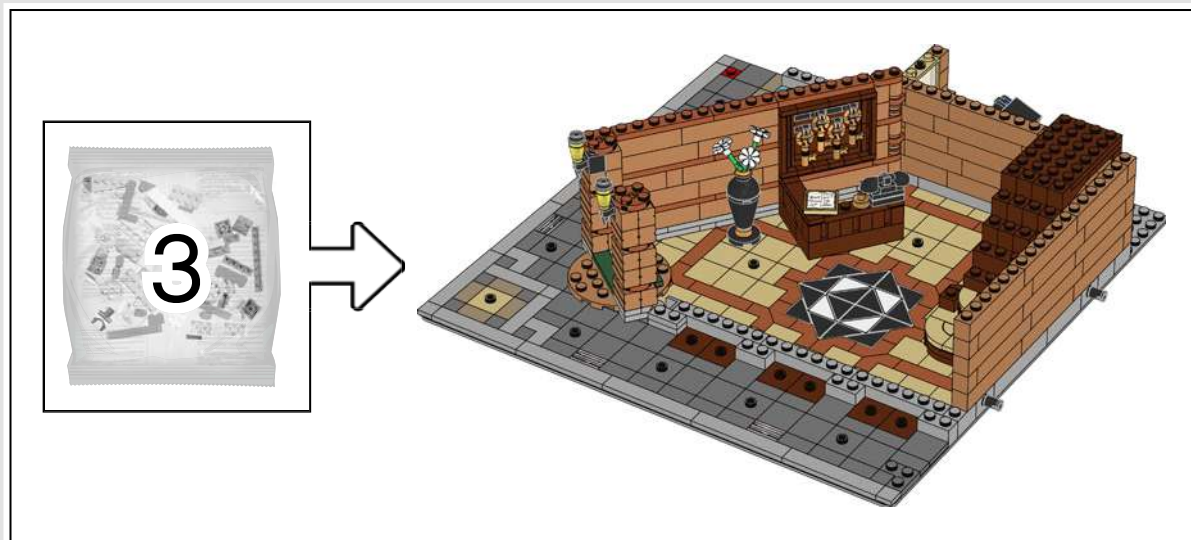

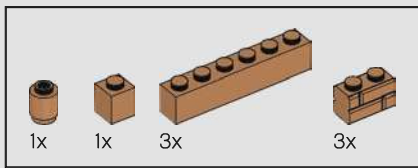

37

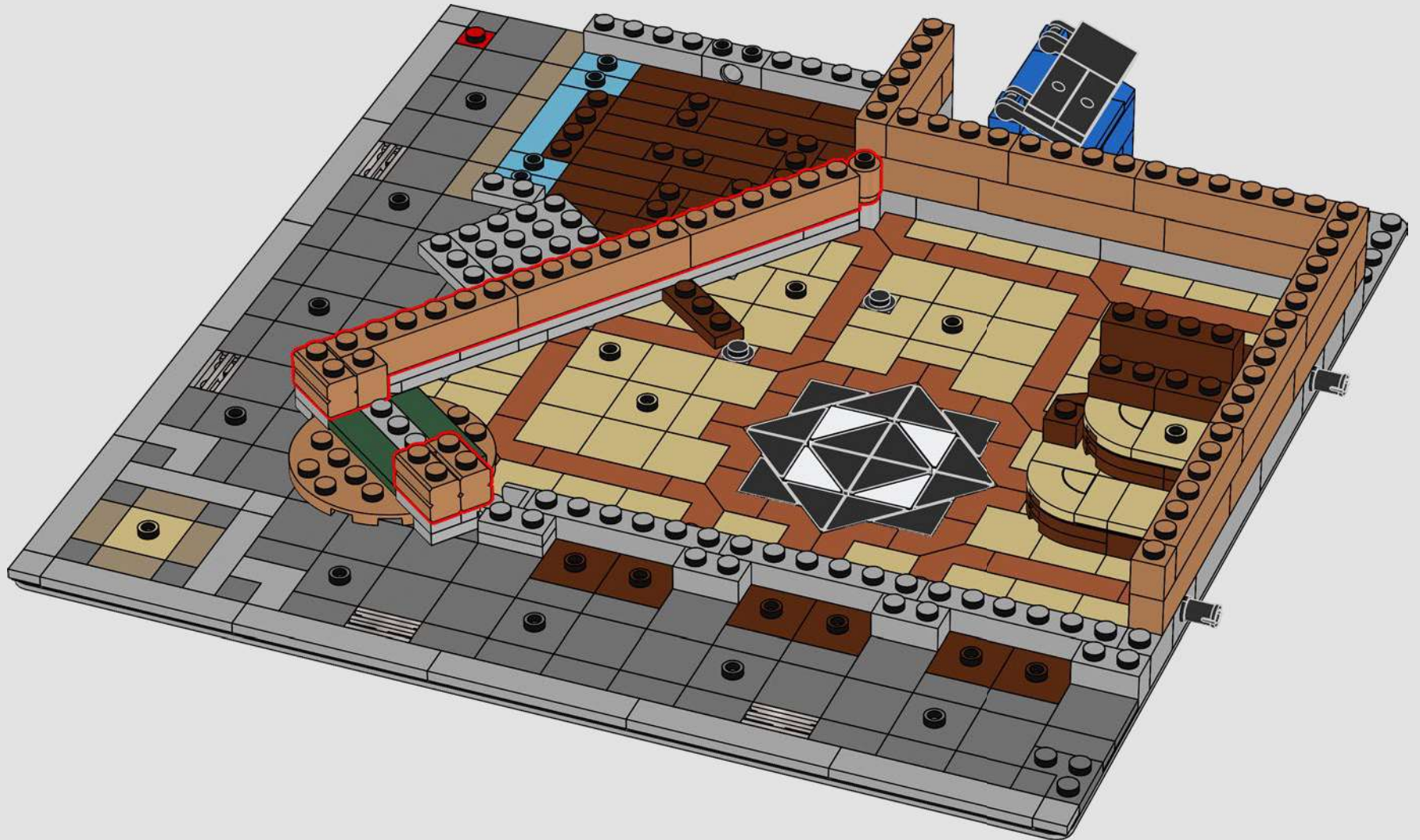

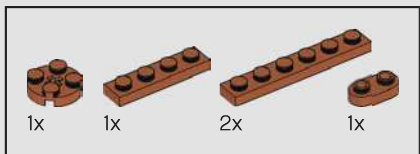

38

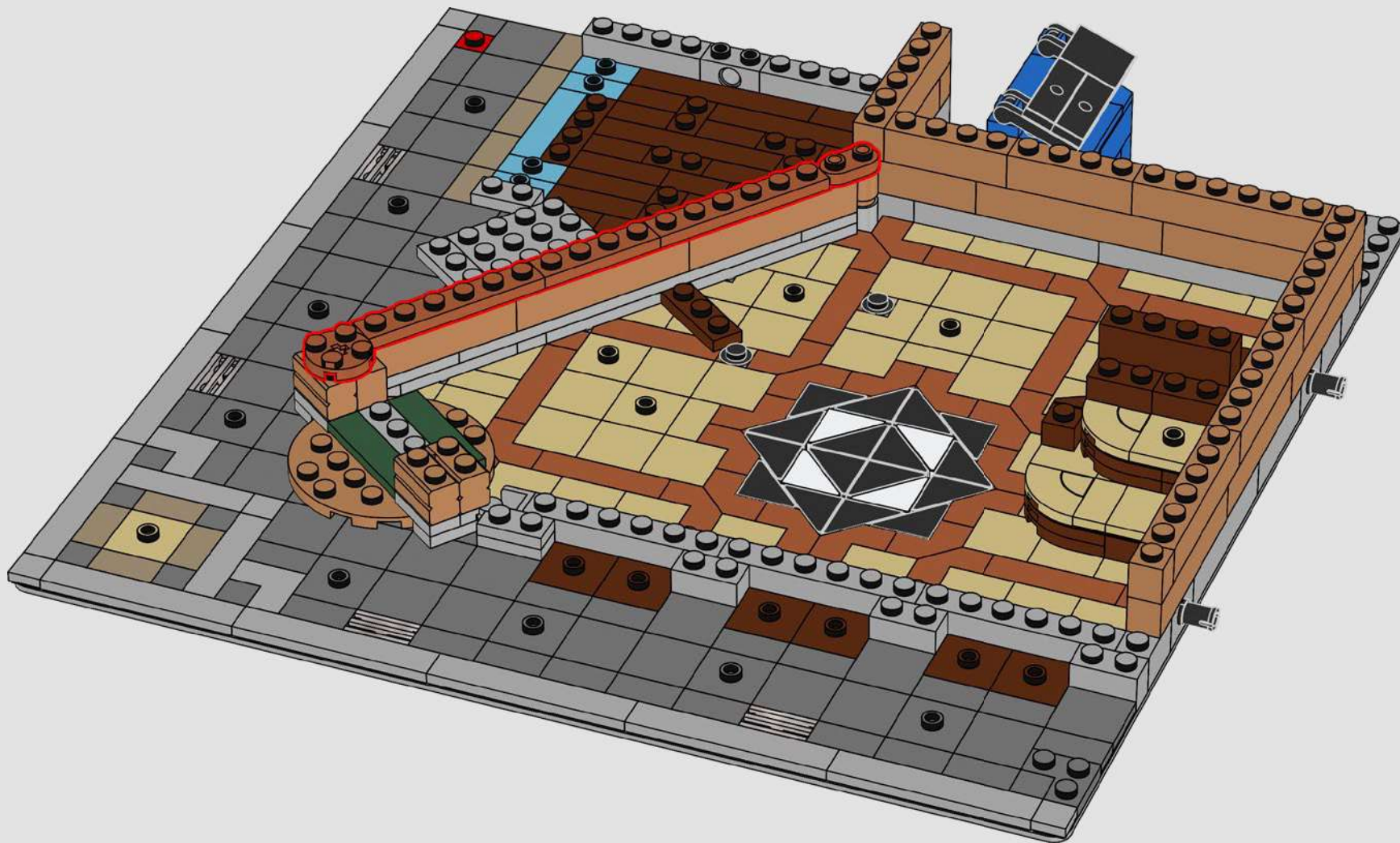

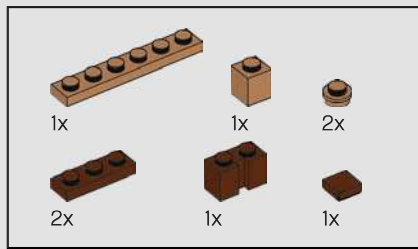

39

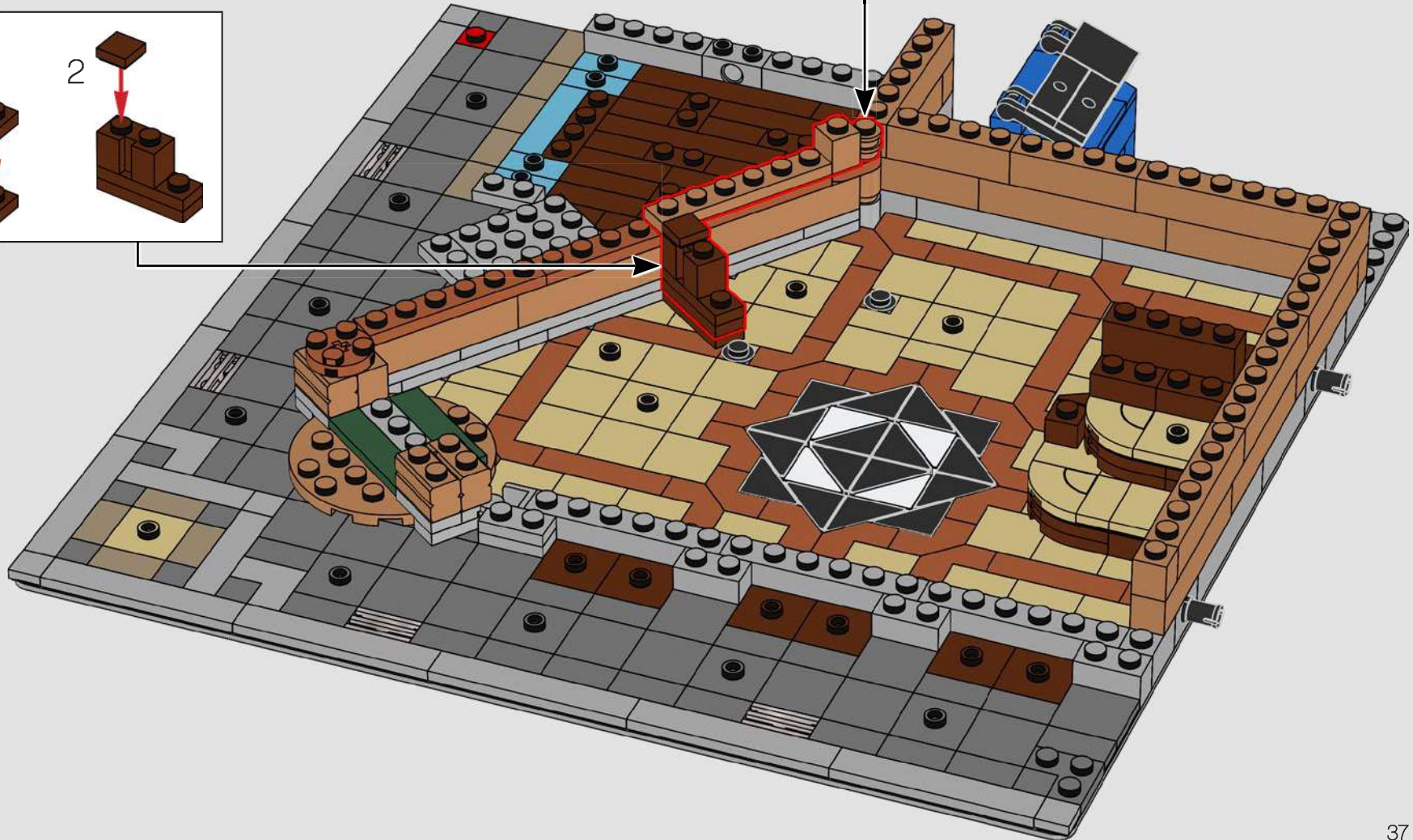
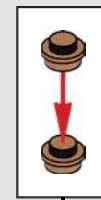
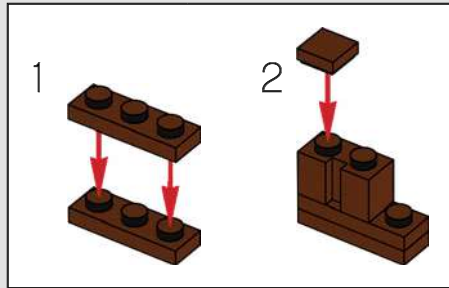

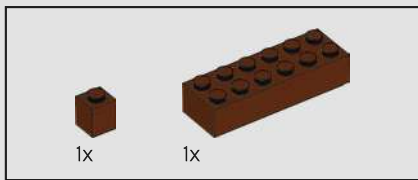

40

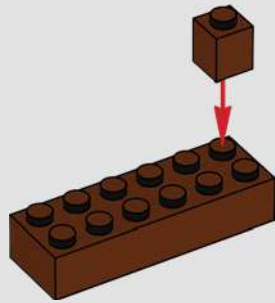

41

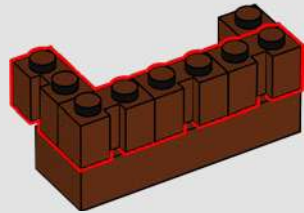

42

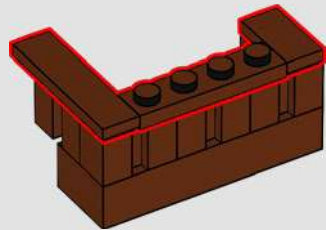

Many of the guests who've stayed in this hotel are residents of earlier Modular sets!
Can you identify them?



43

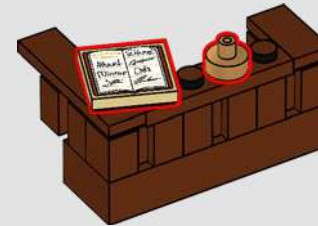

44

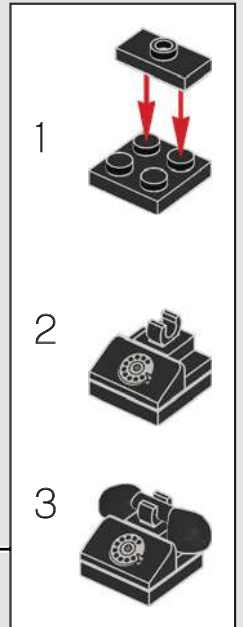
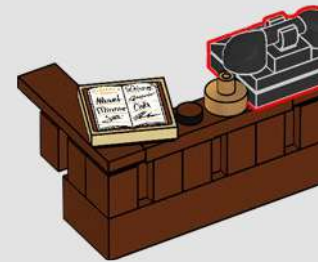



The Receptionist enjoys calling her friend
the Lieutenant in the 10278 Police Station
set on this phone.

45

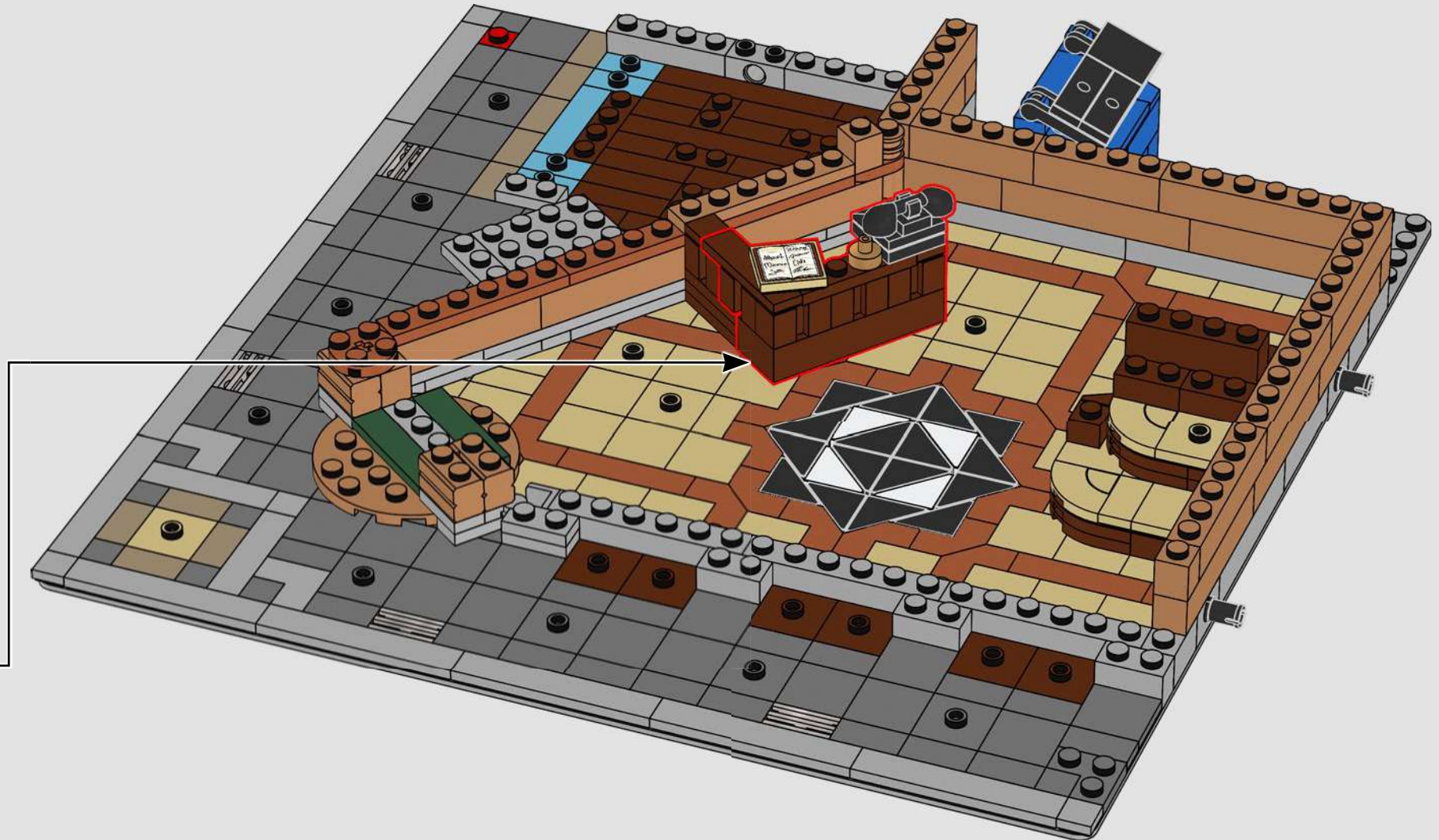

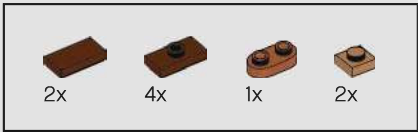

46

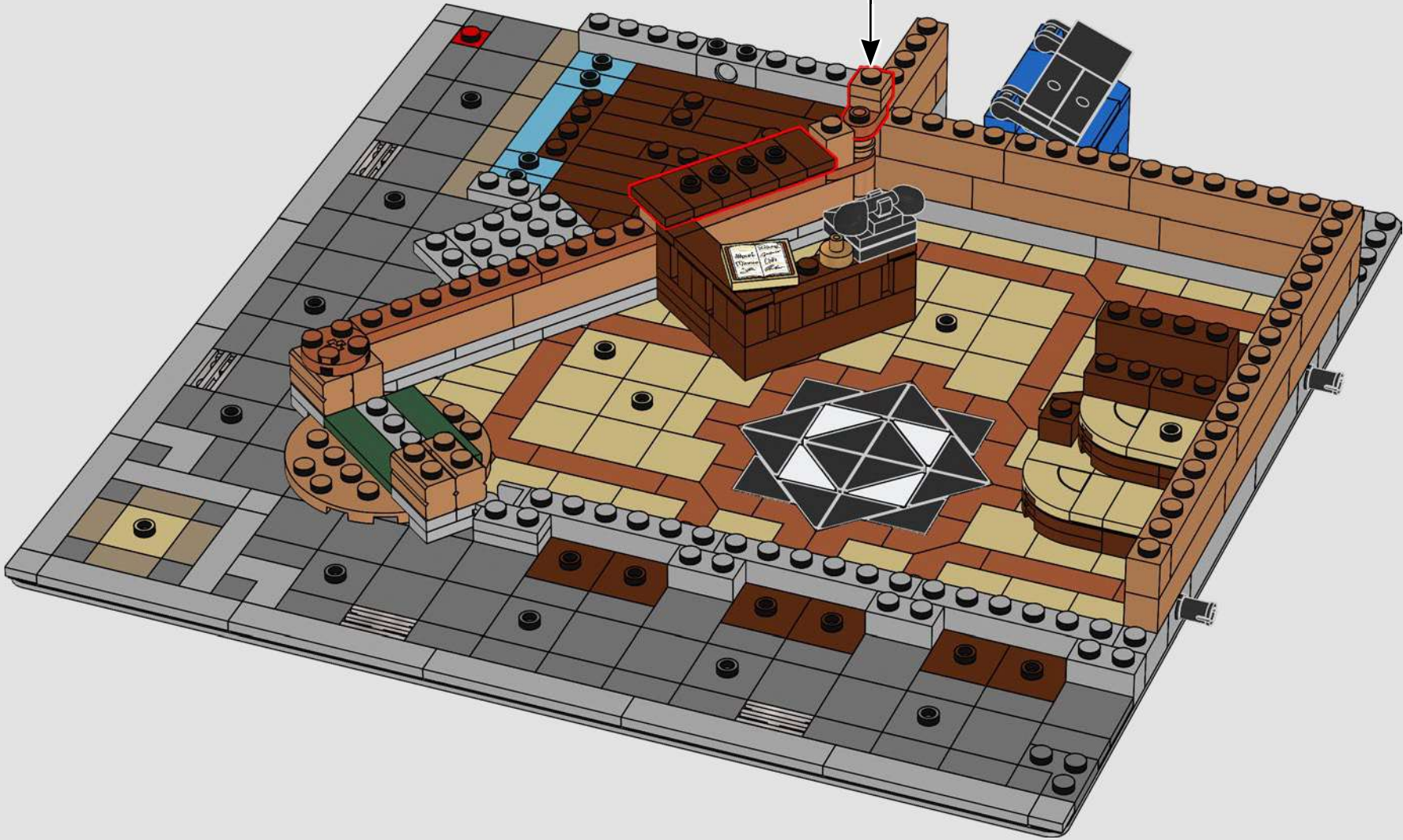
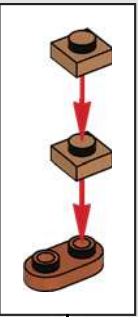

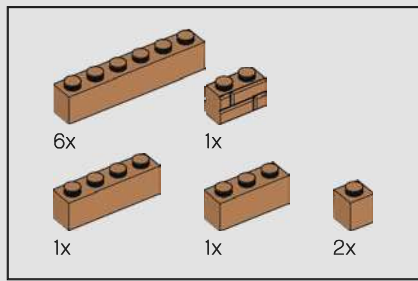

47

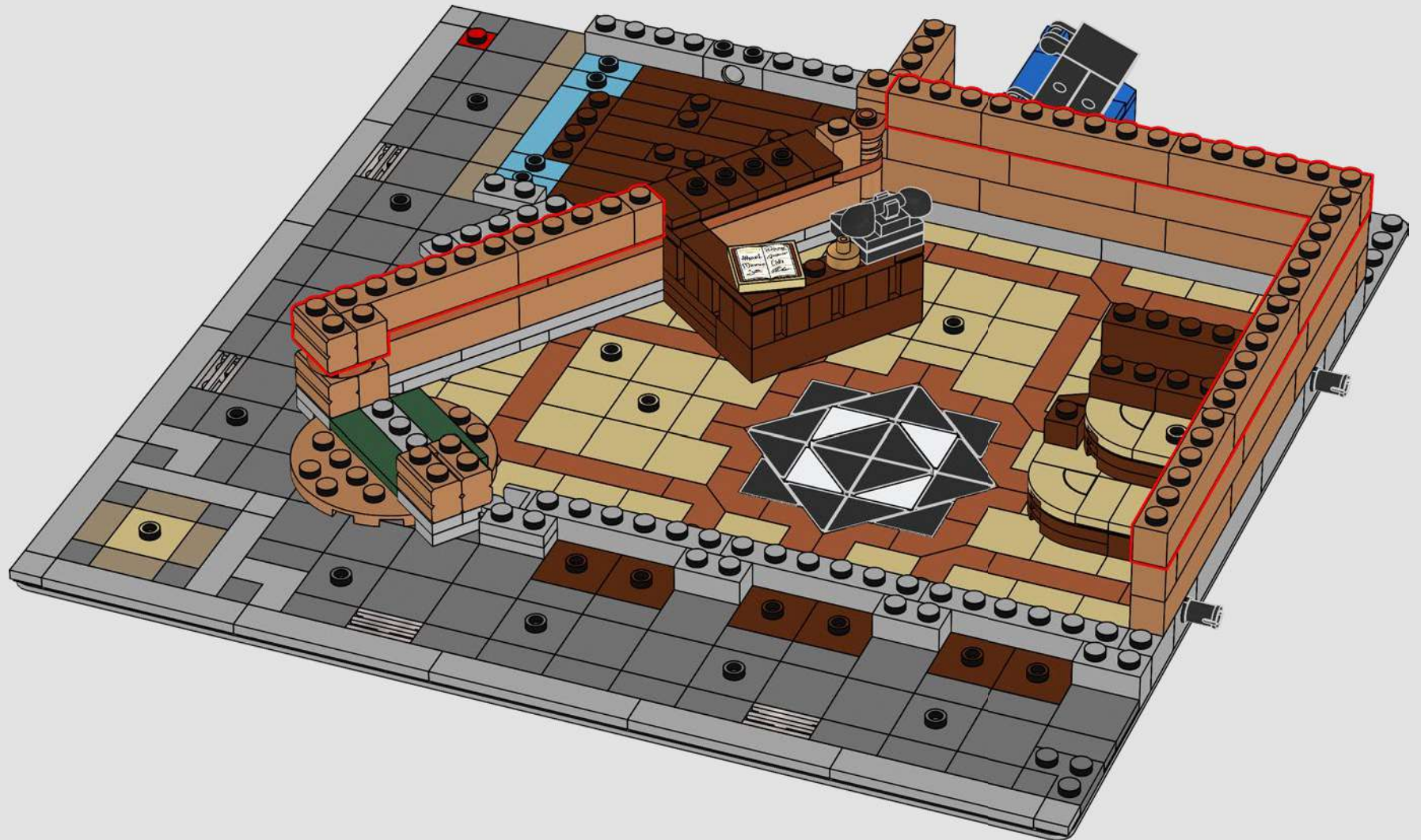

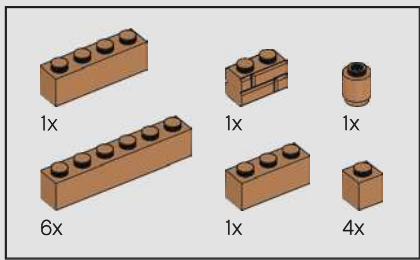

48

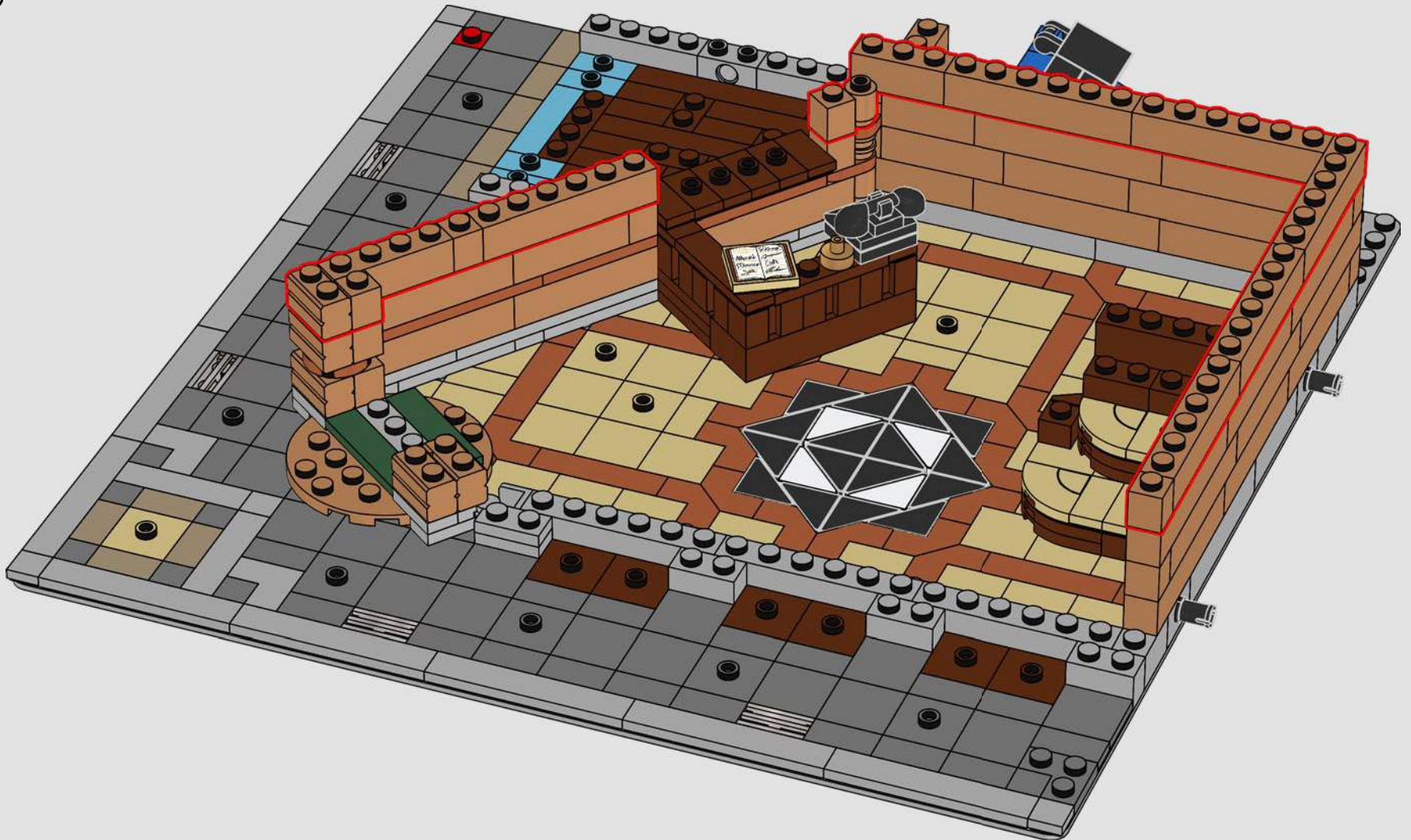

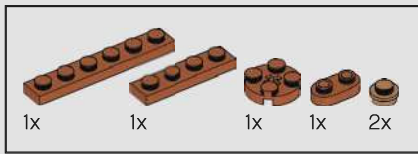

49

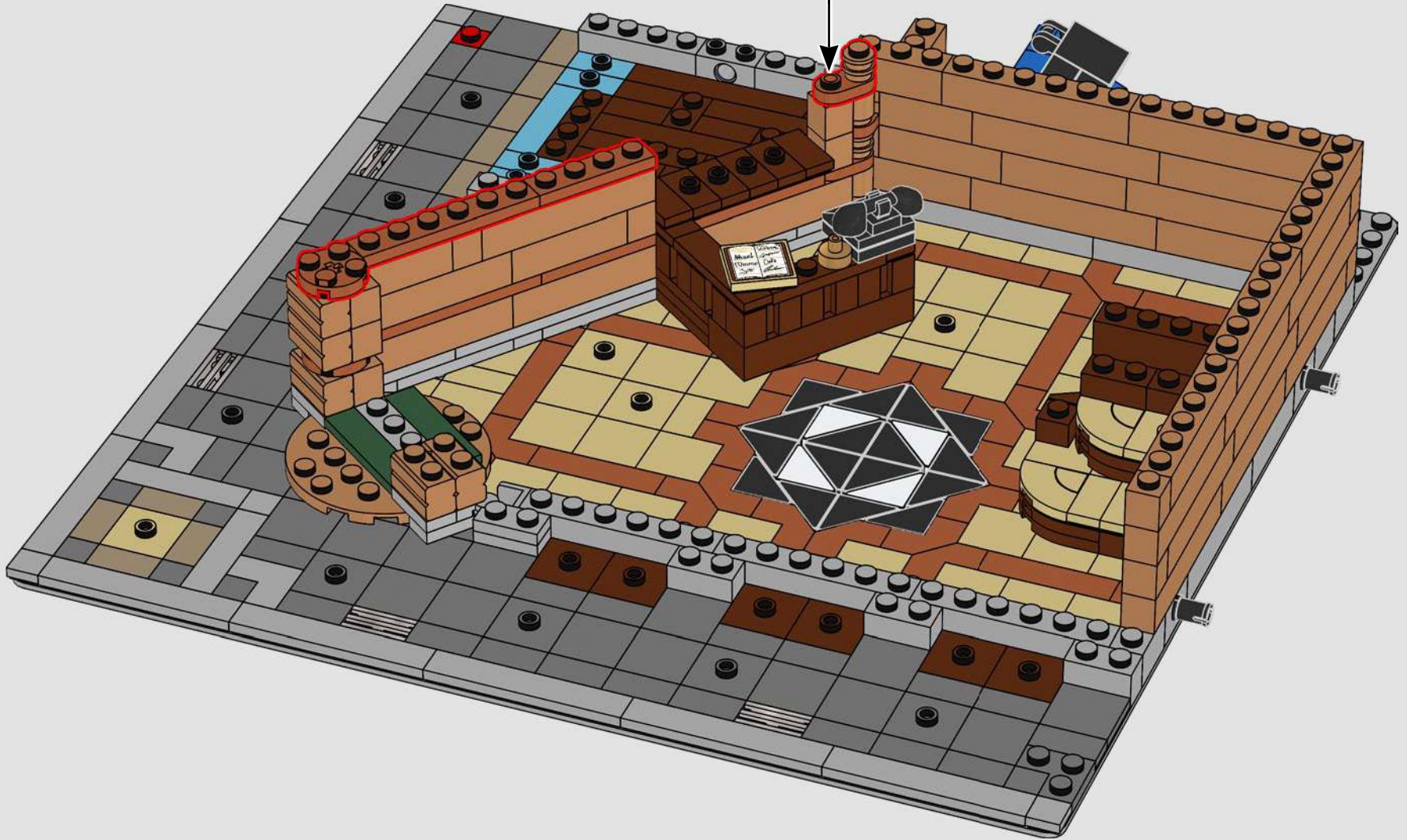
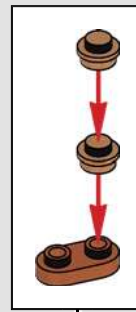

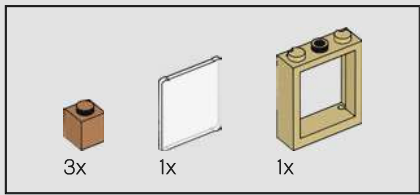

50

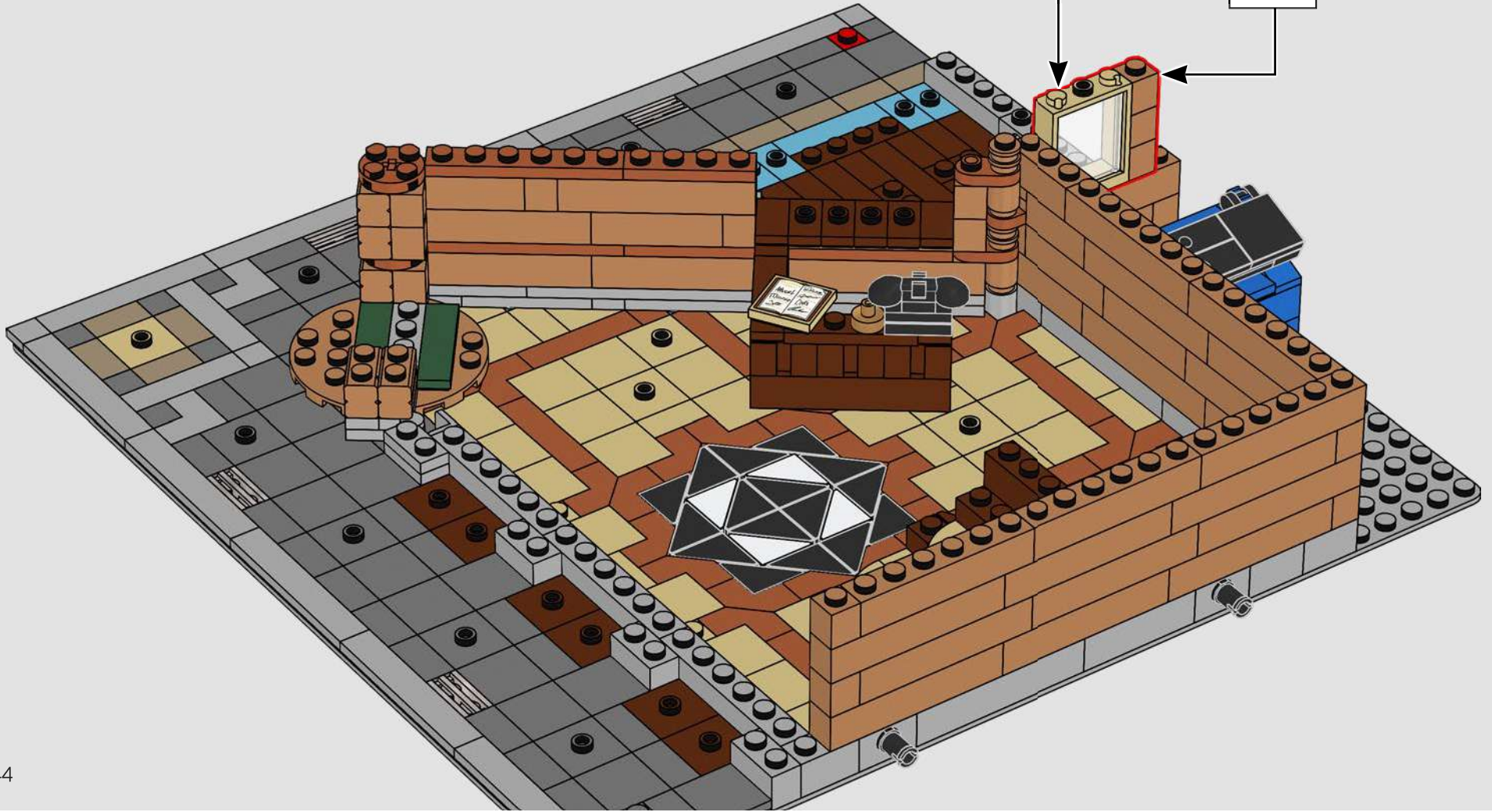
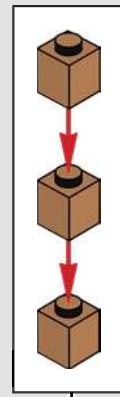
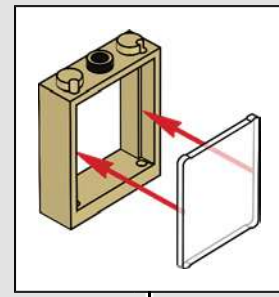

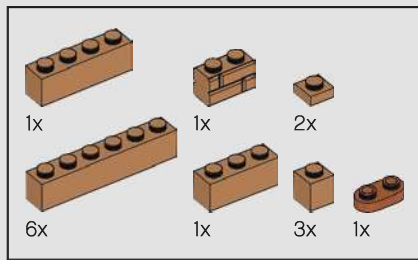

51

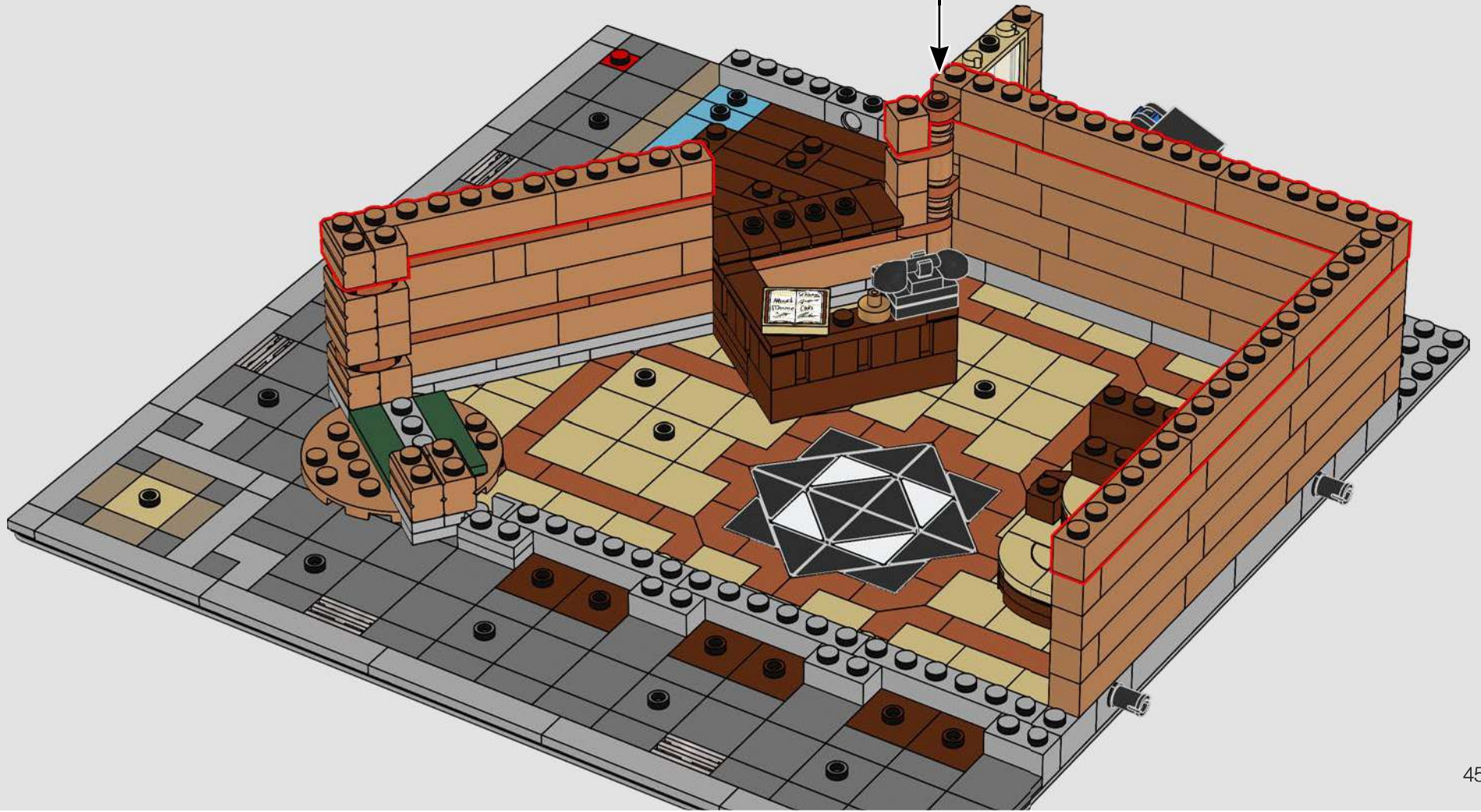
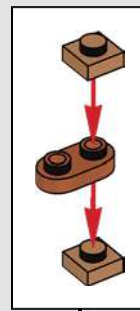

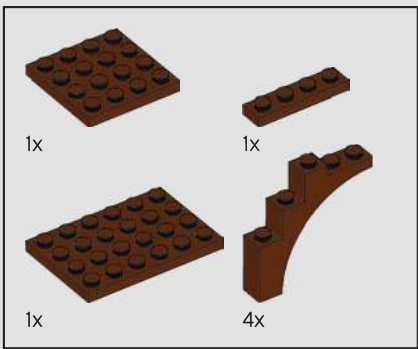

52

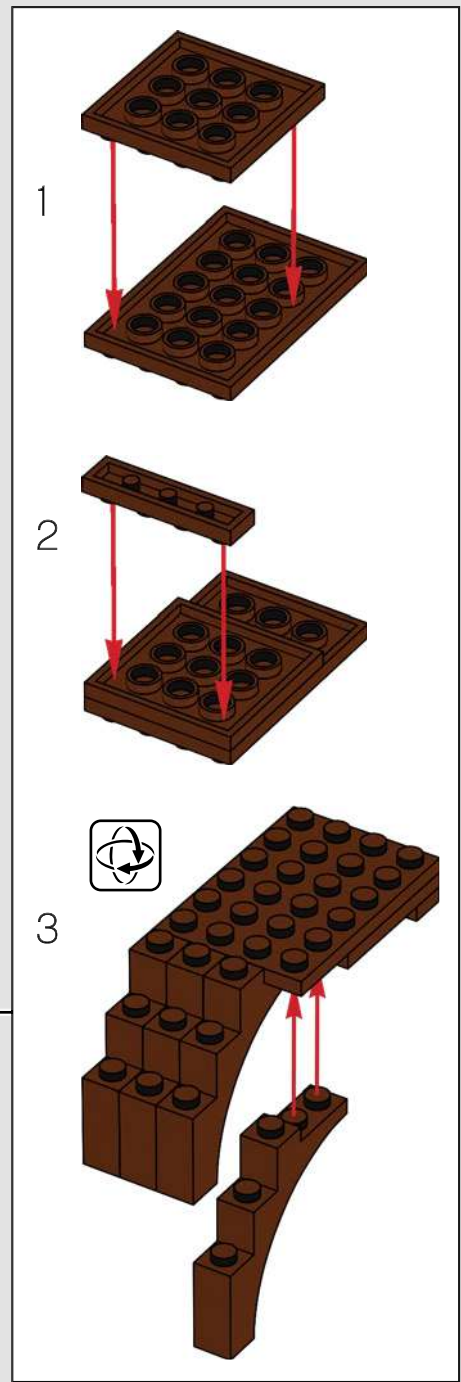
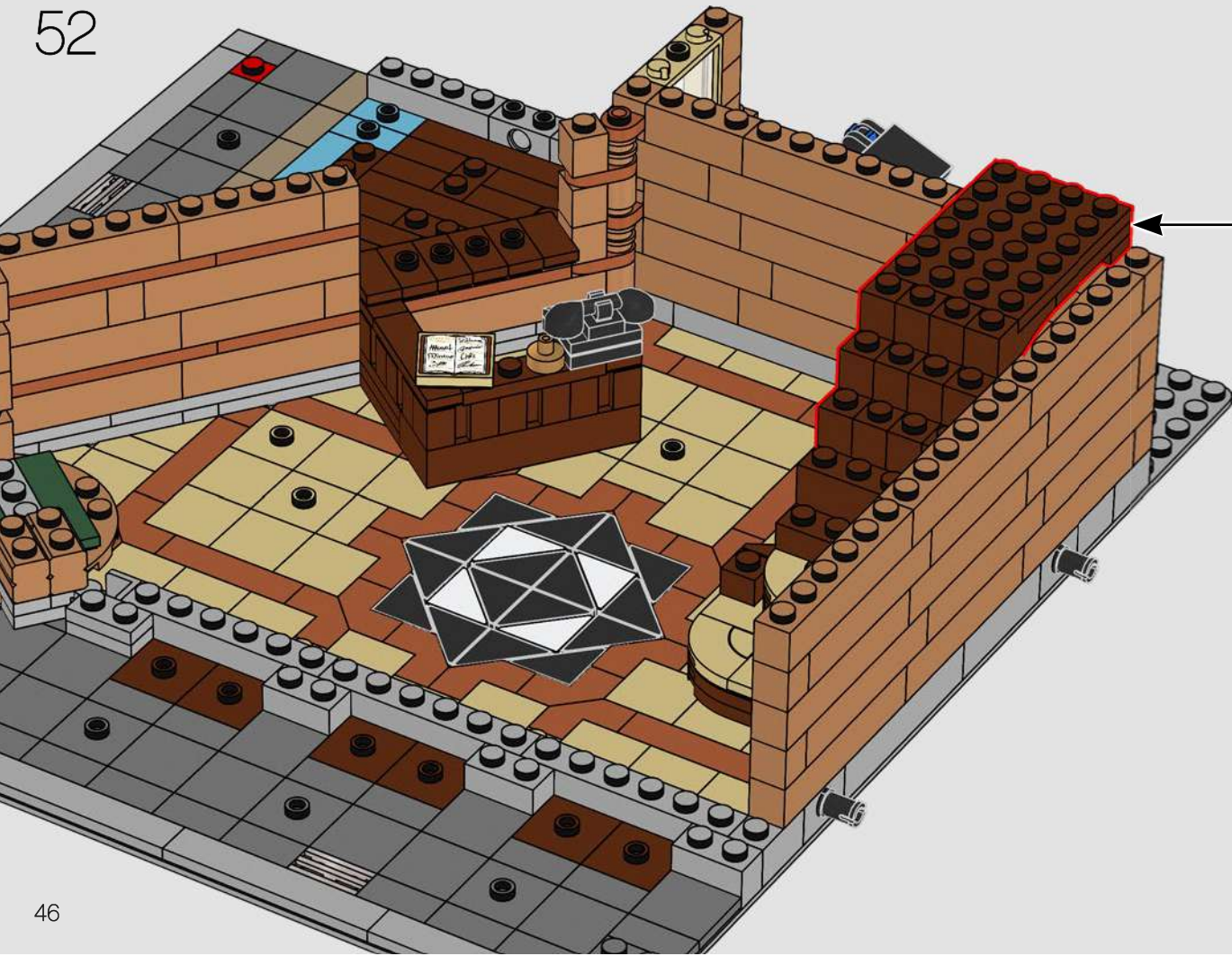

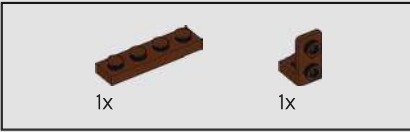

53

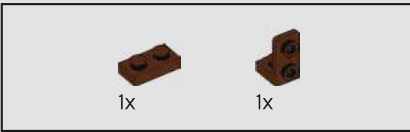
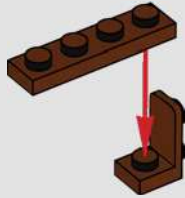

54

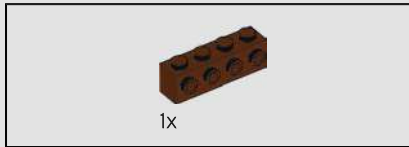
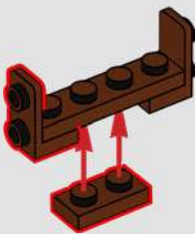

55

1x

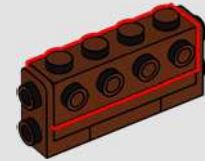

56

1x

2x

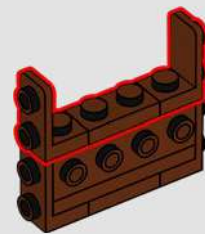

57

2x

2x

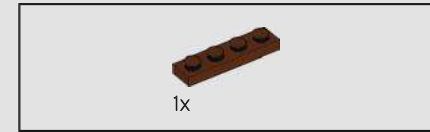

58

1x





59



60



61

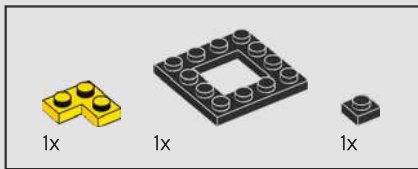
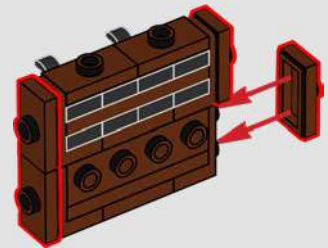

62

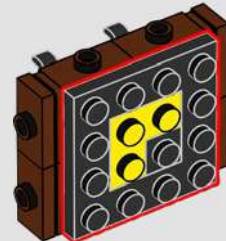

63

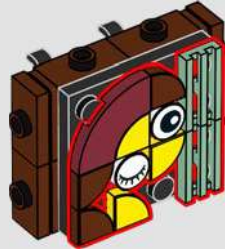

64

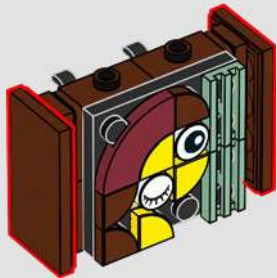

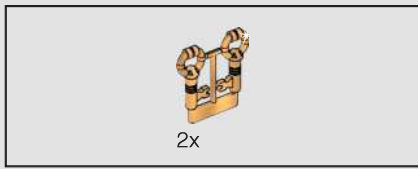

65



66

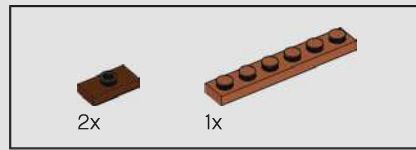
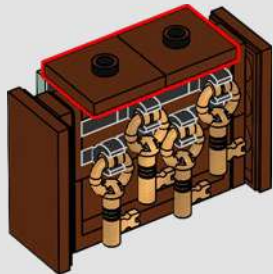

67

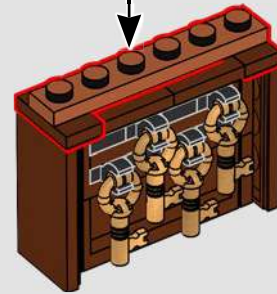
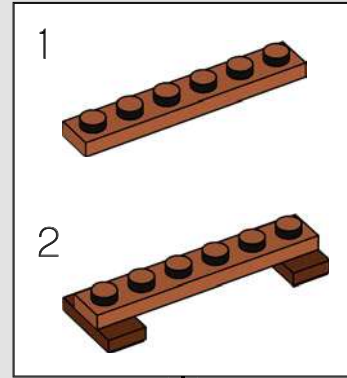

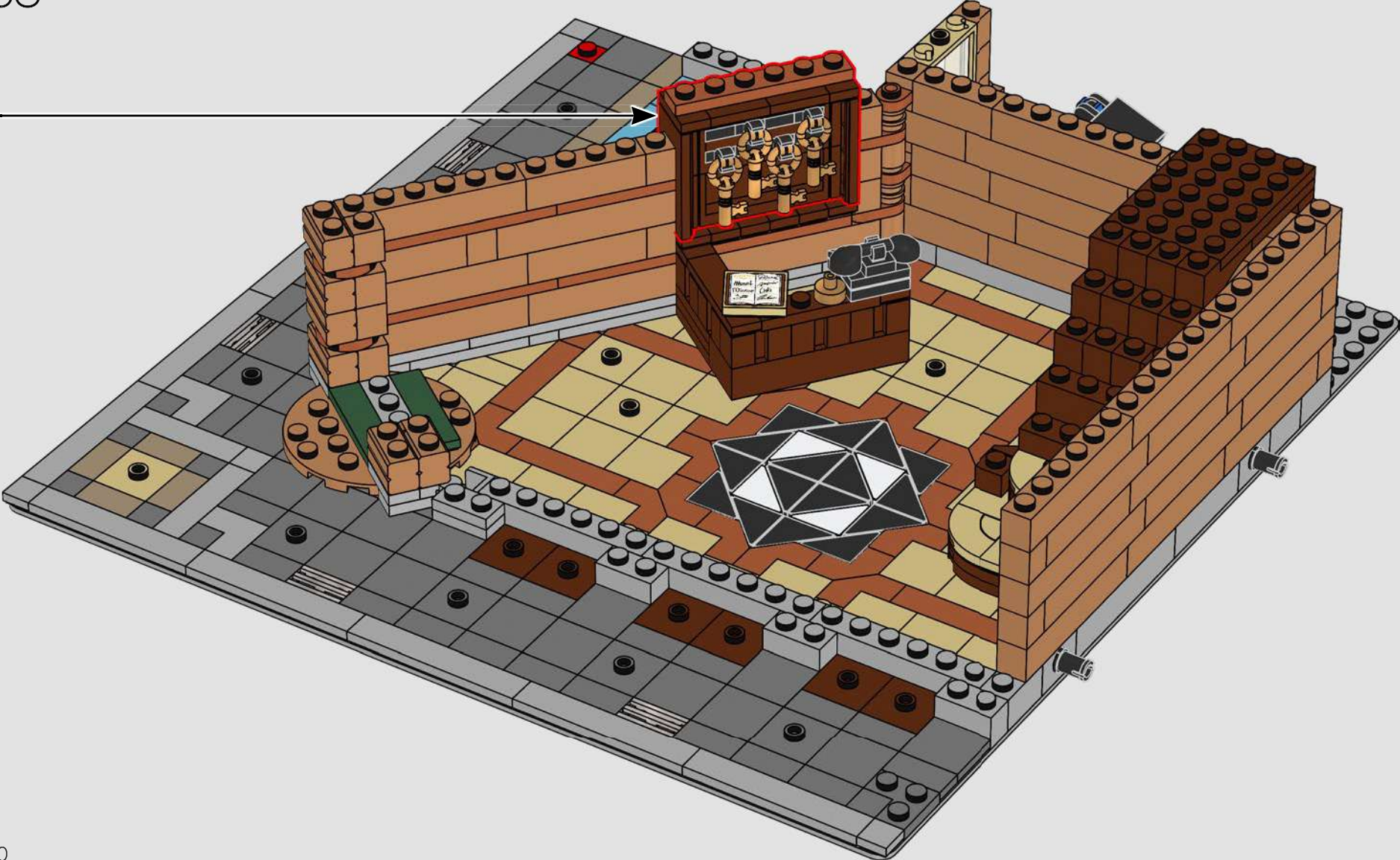

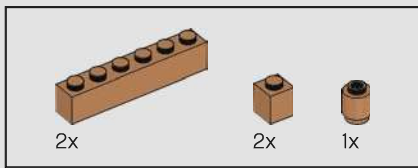

69

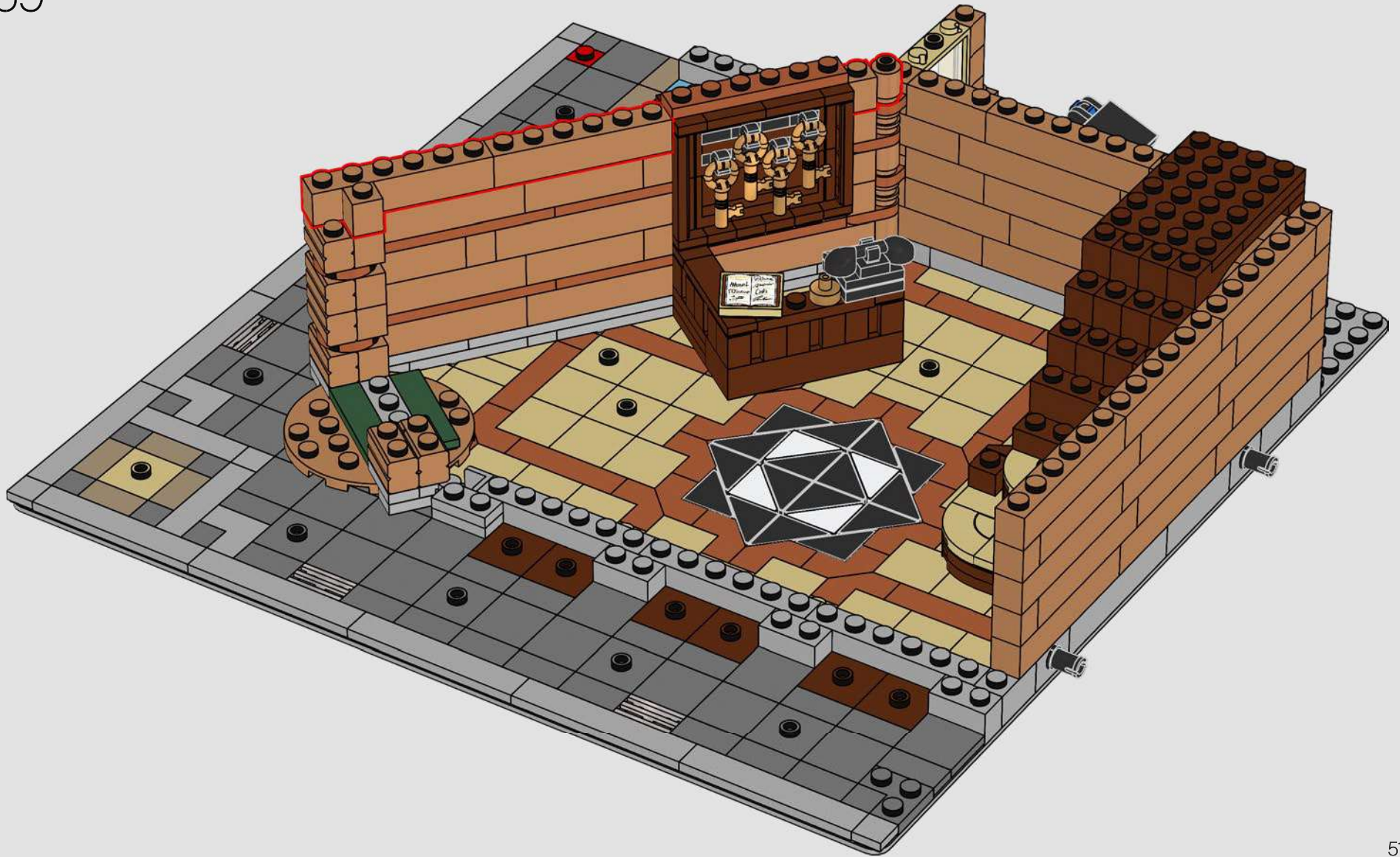



70

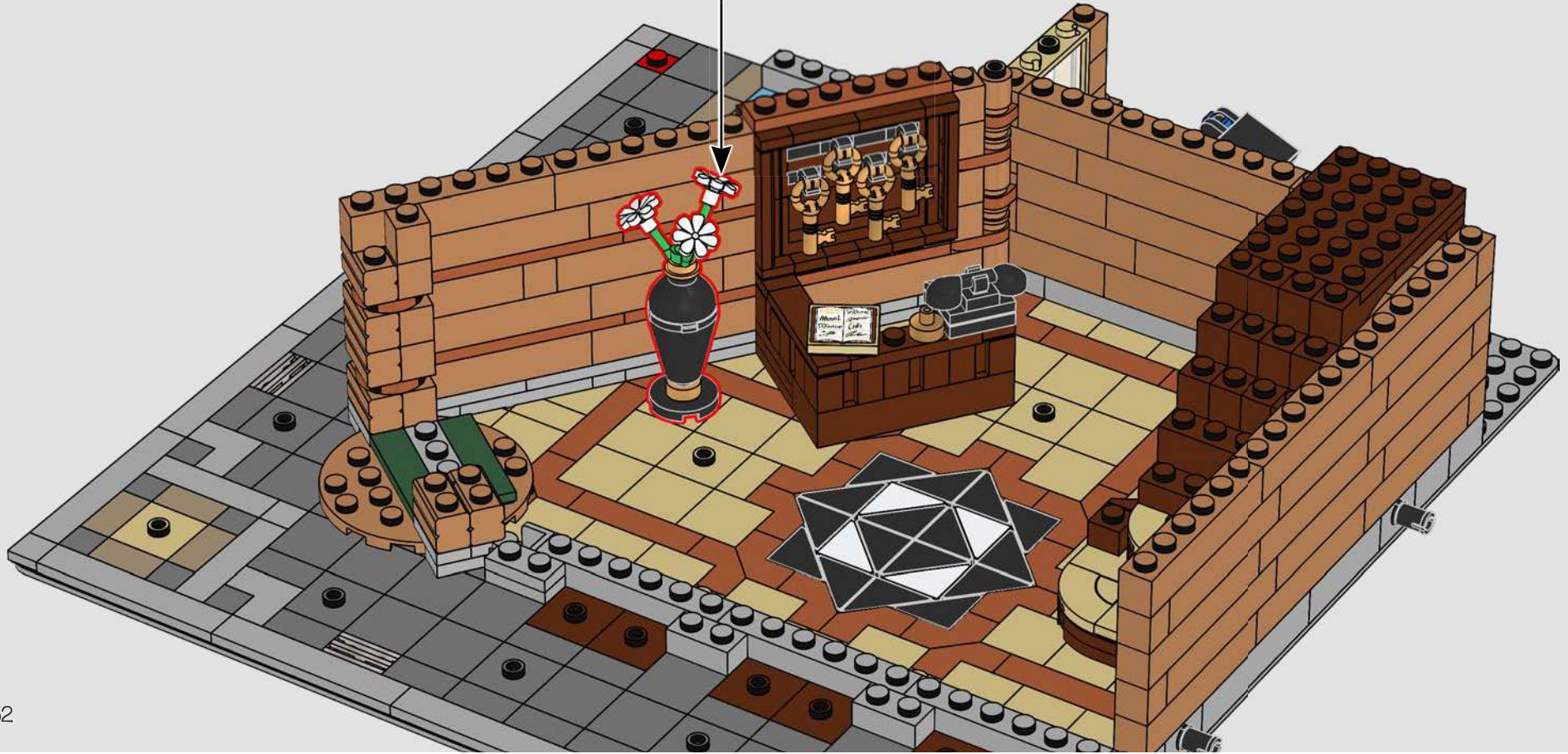
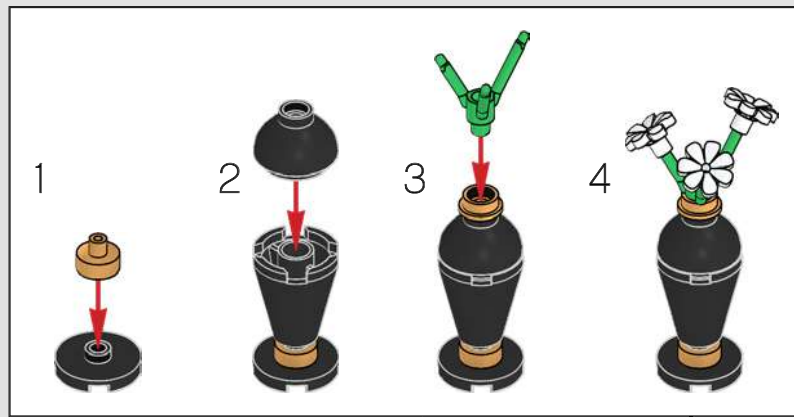



71

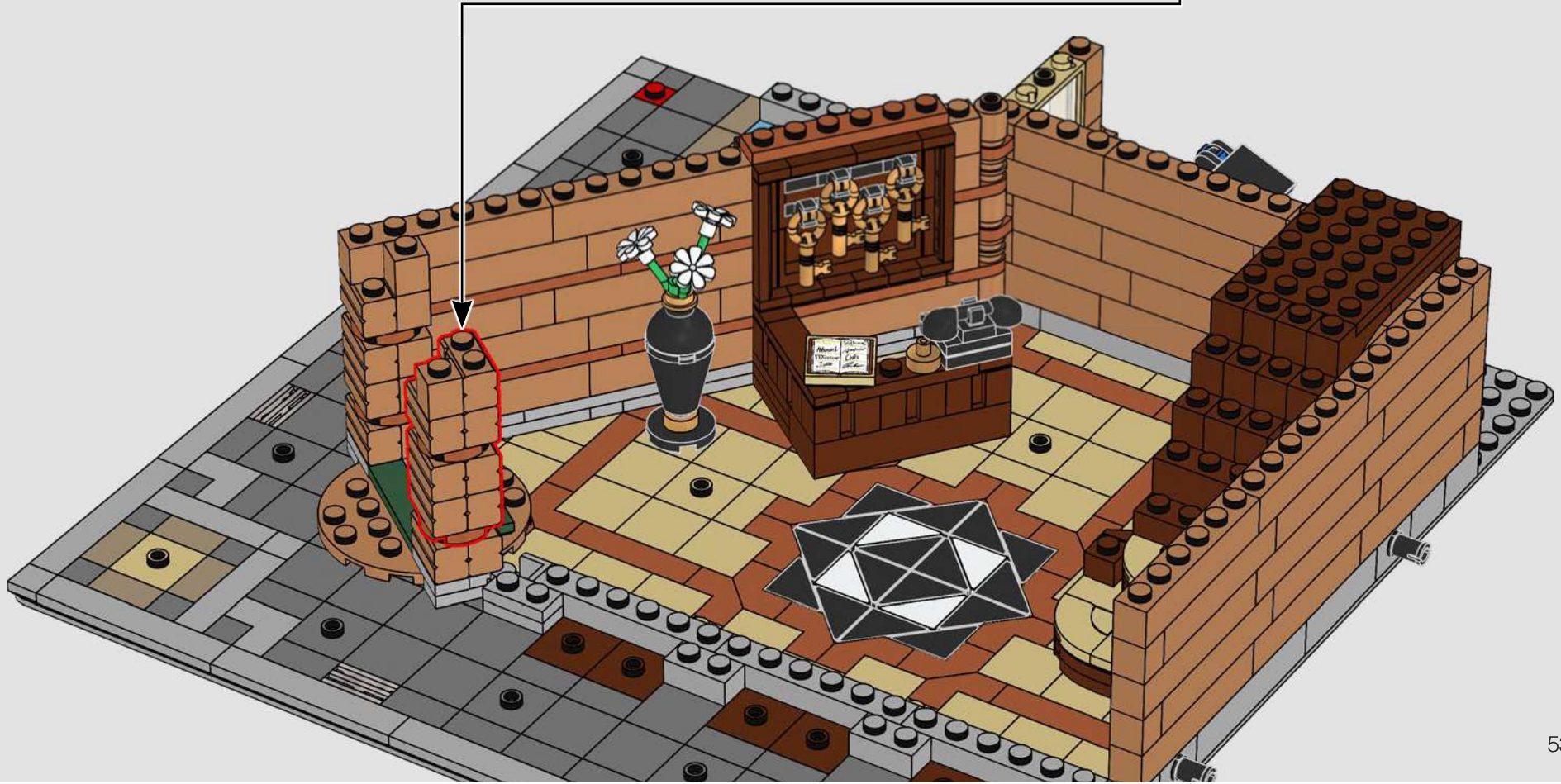
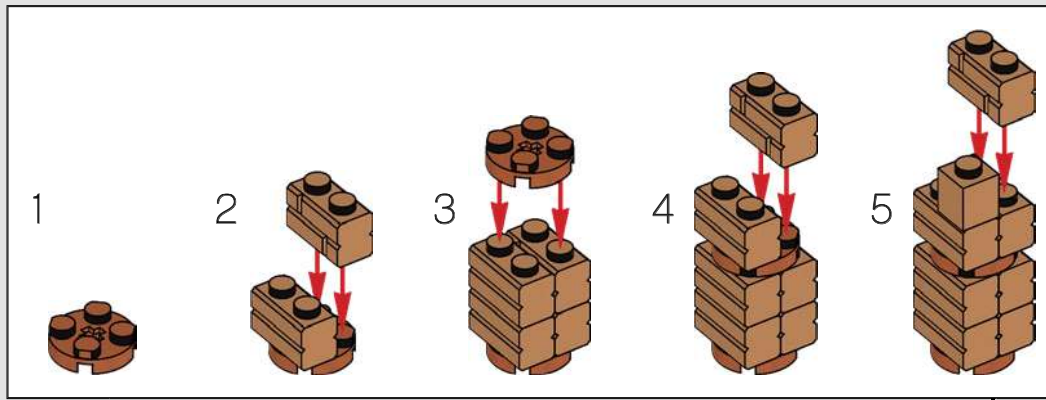

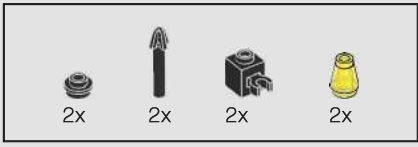

72

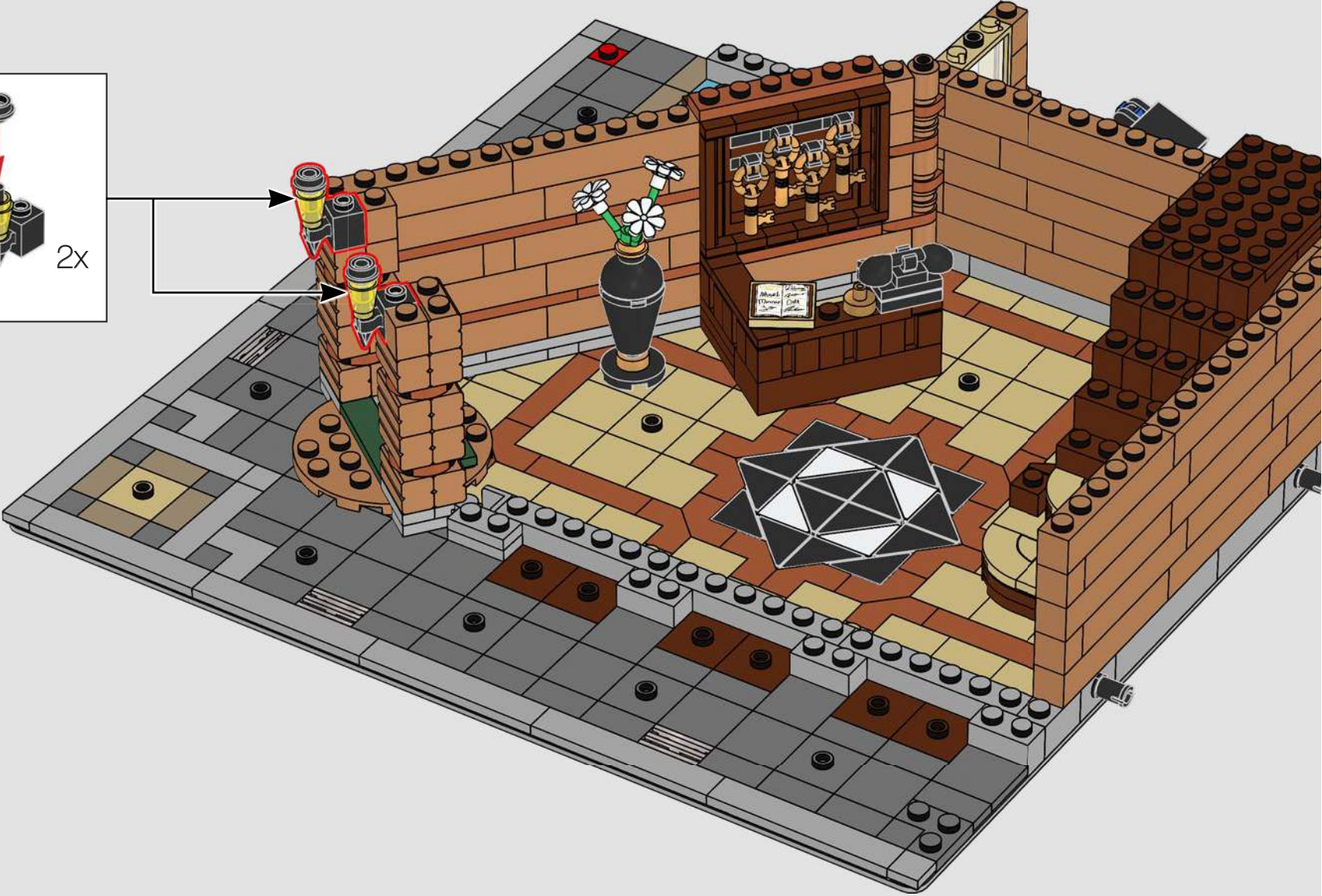
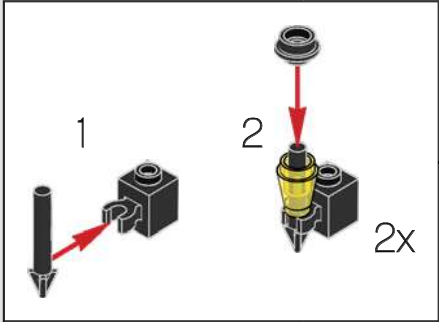

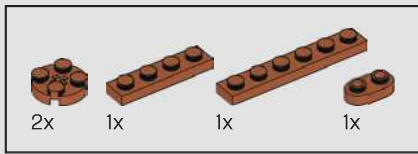

73

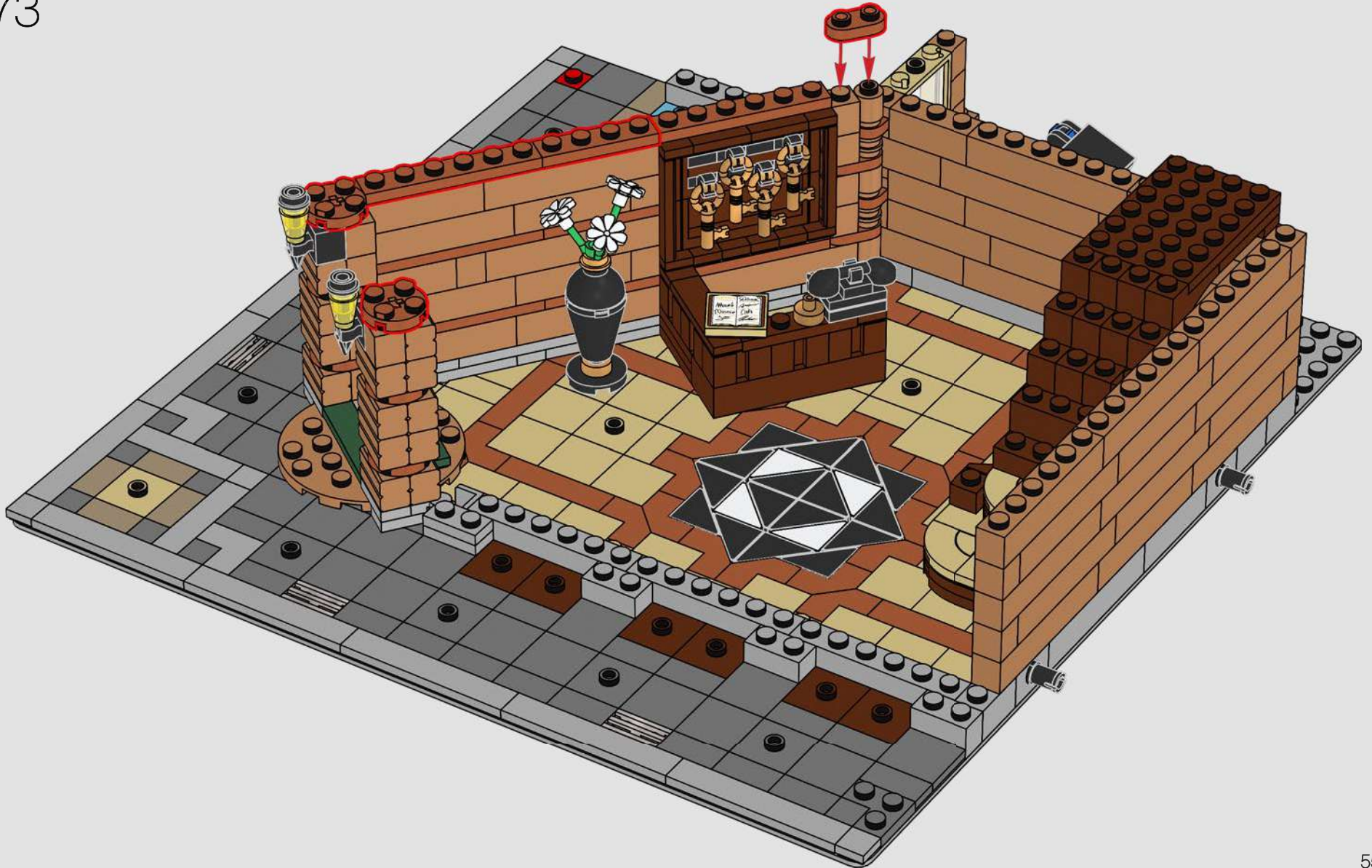

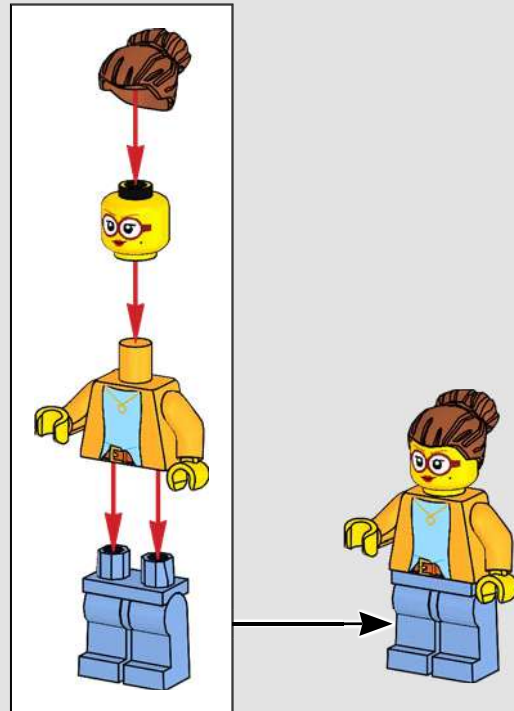

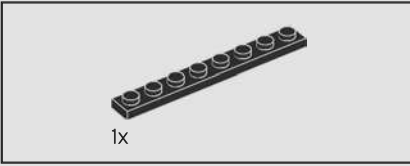

74

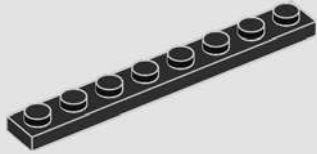

75

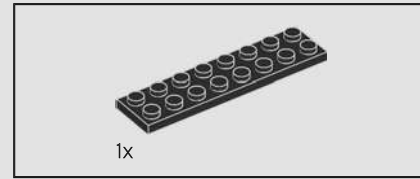
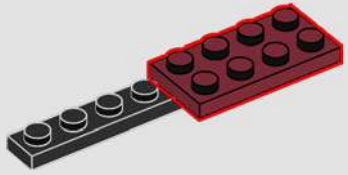

76

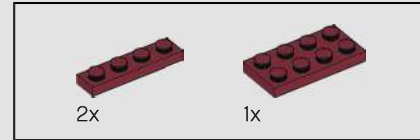
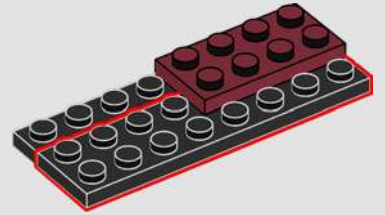

77

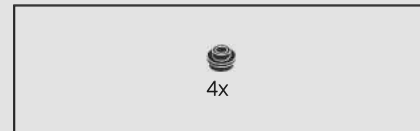
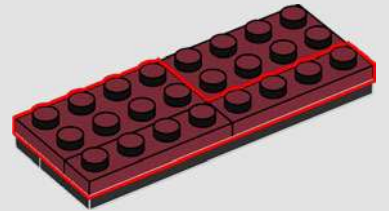

78

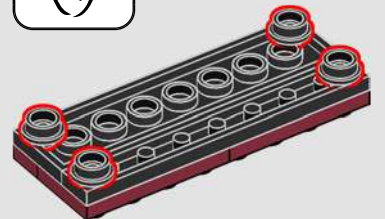
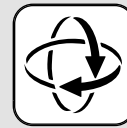



79

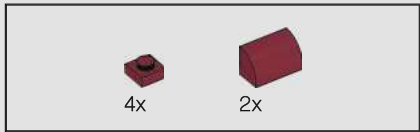
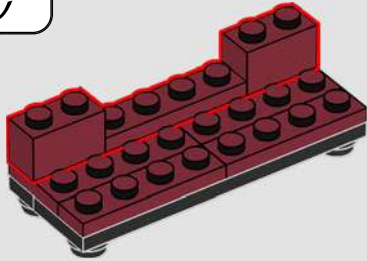

80

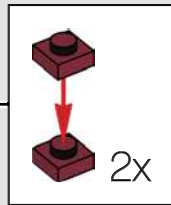
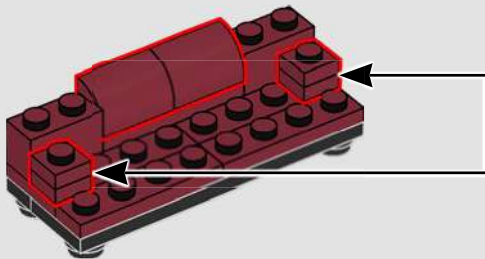

2x



81



82





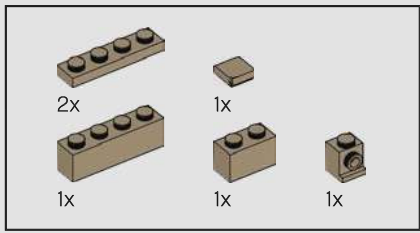

84

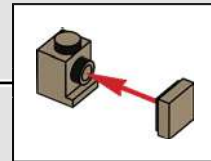
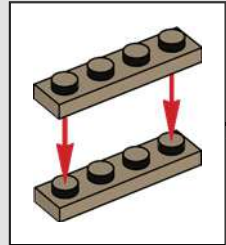
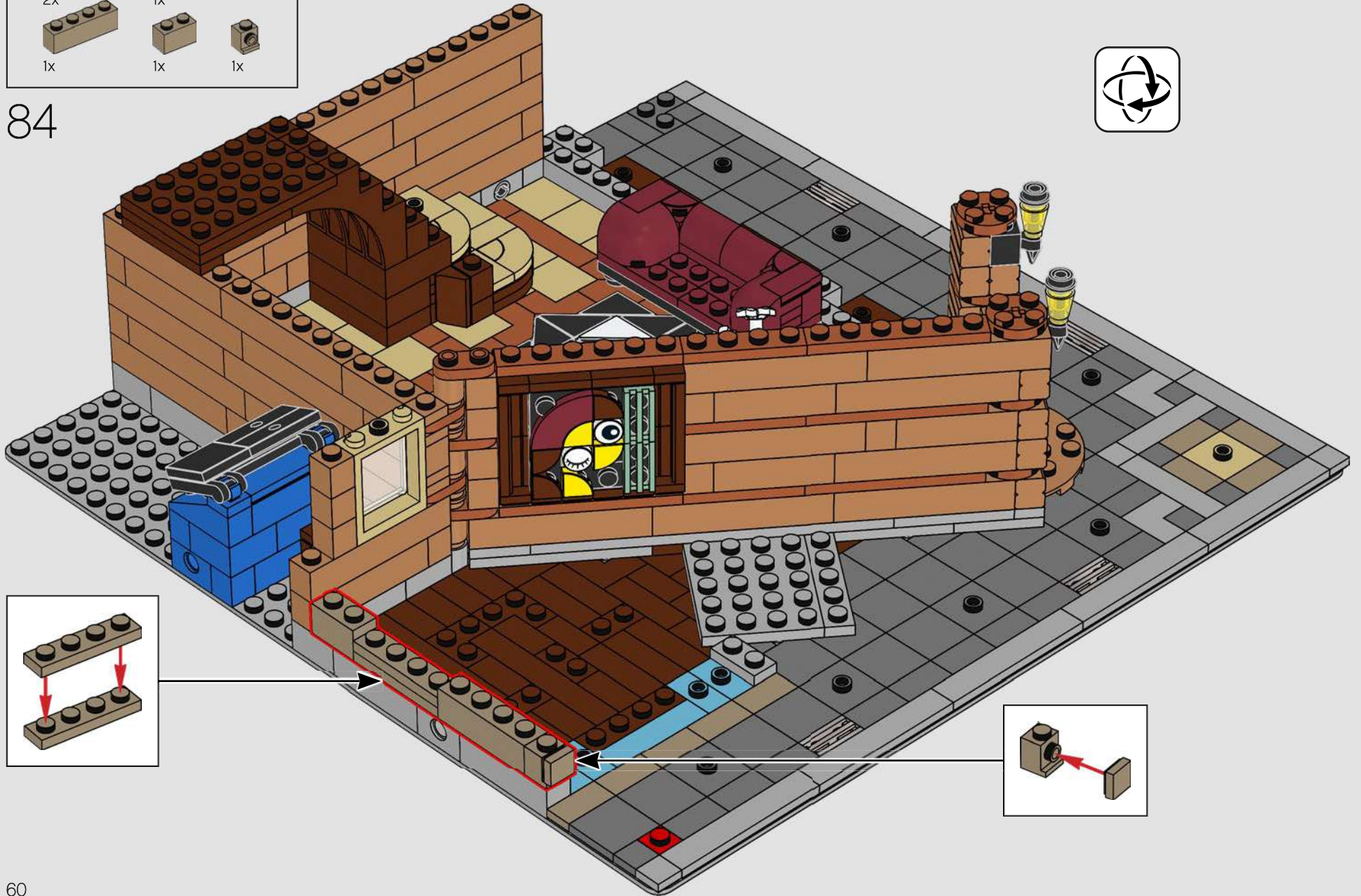
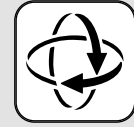

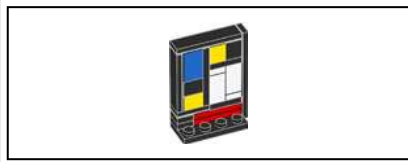

85

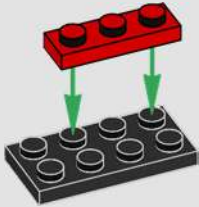

86

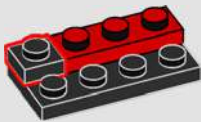

87

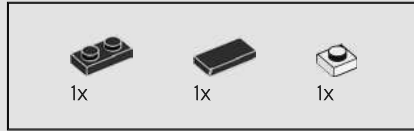
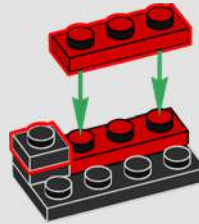

88

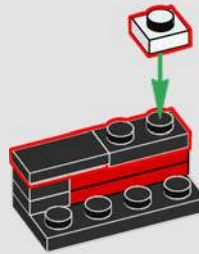

89

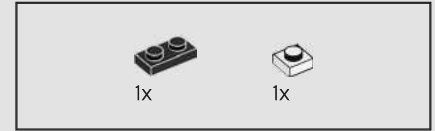

90

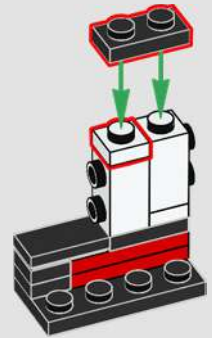



91

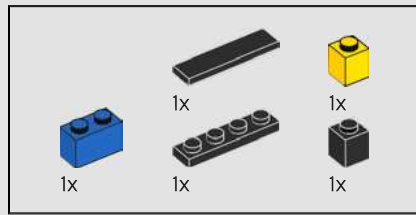

92

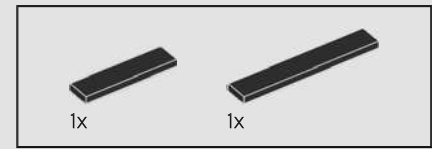
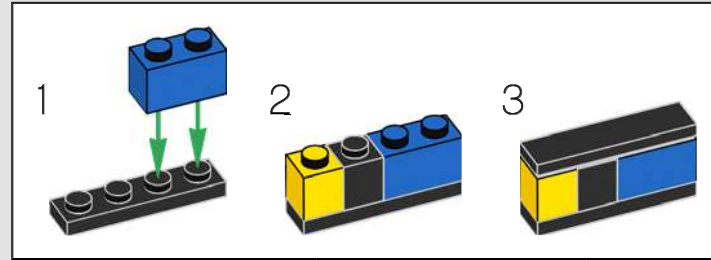

93

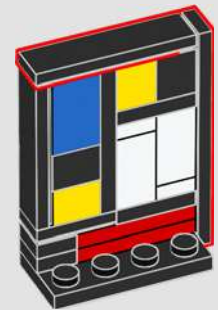

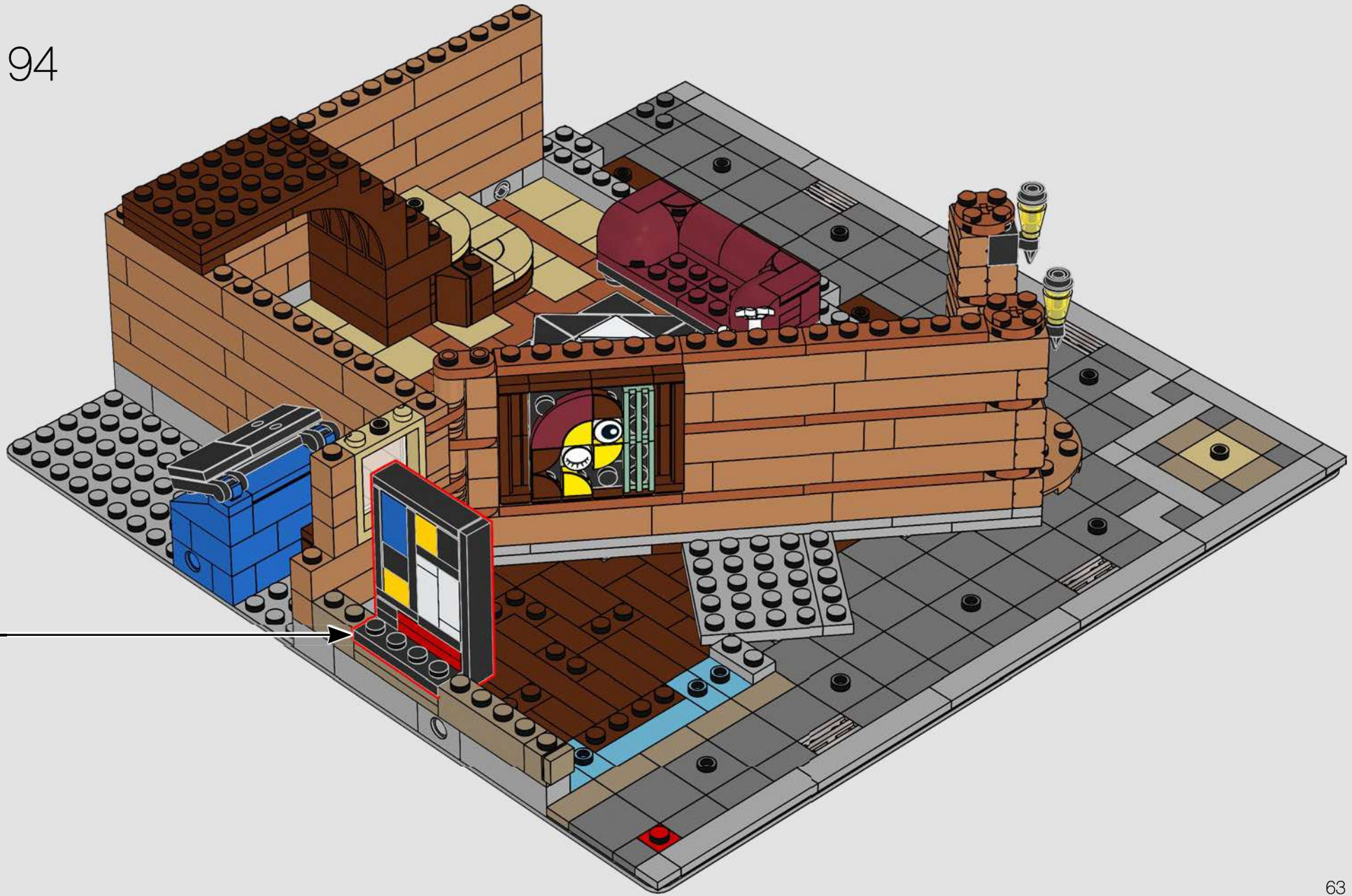

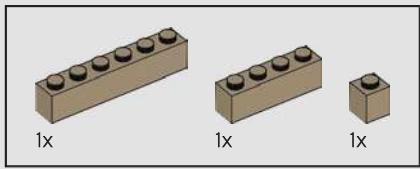

95

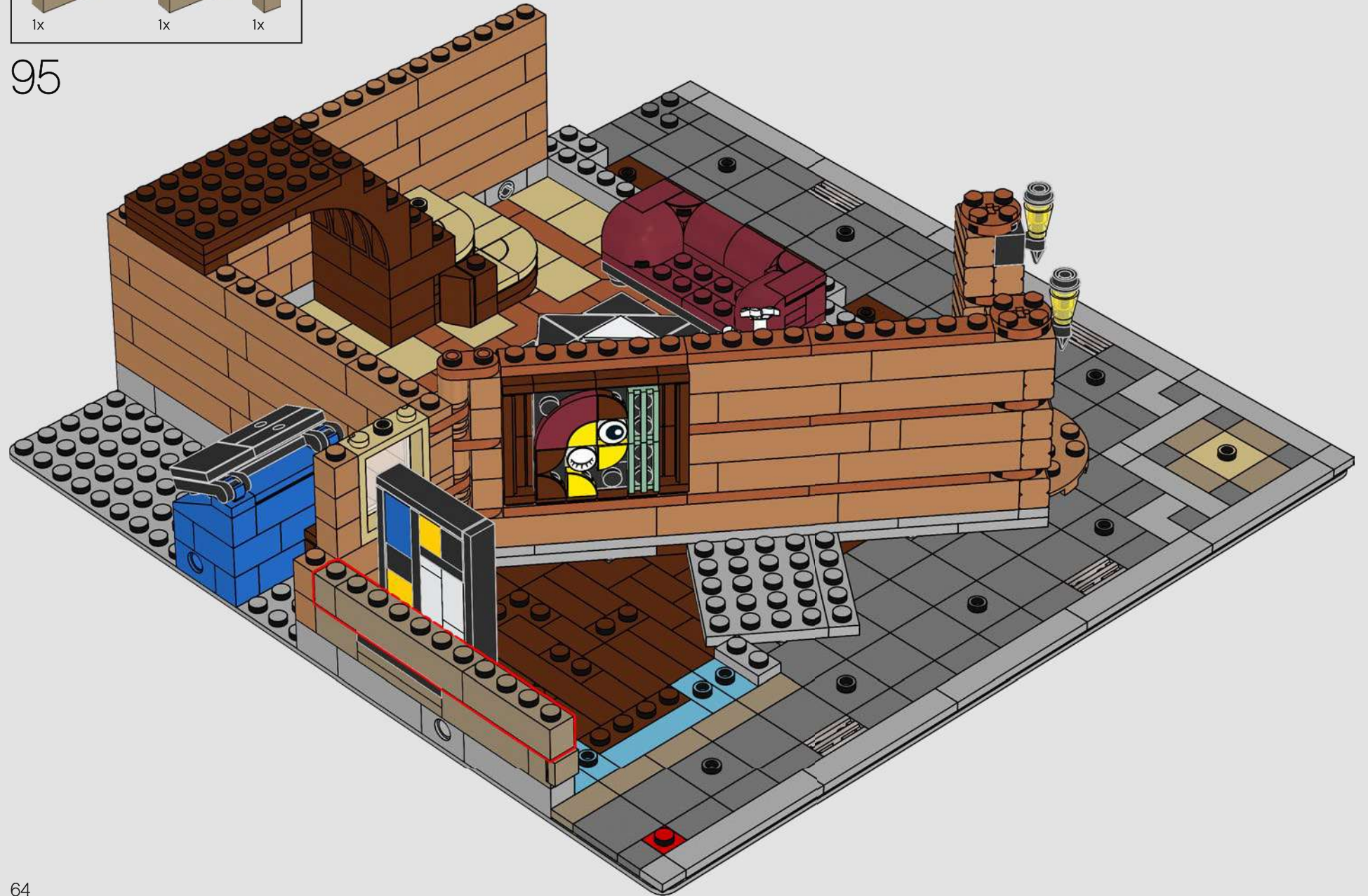

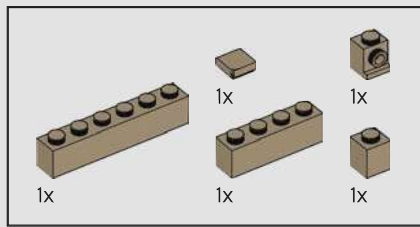

96

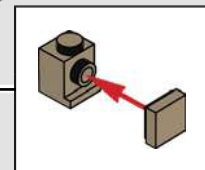
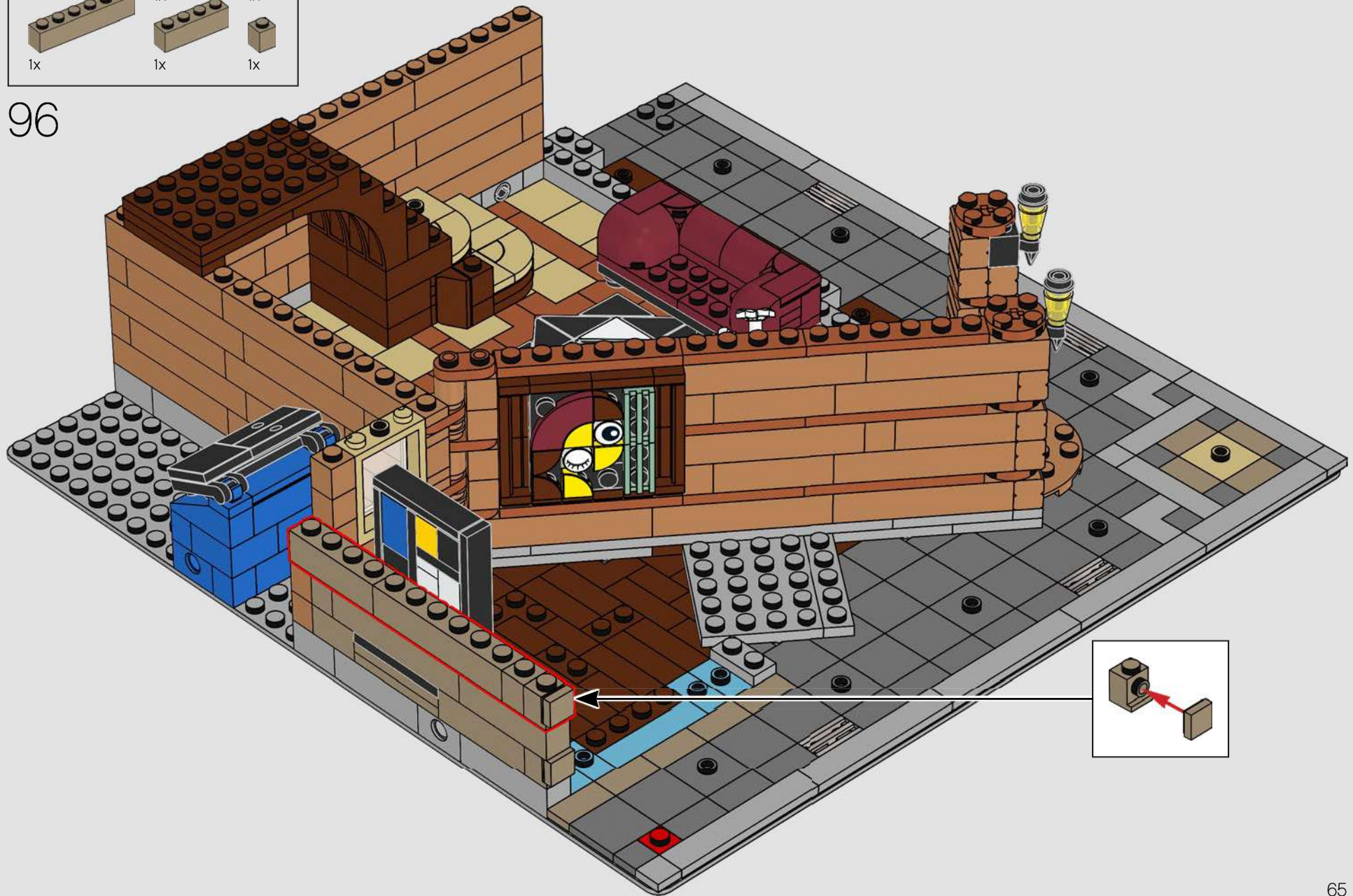

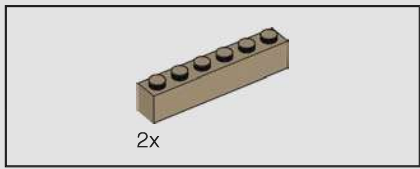

97

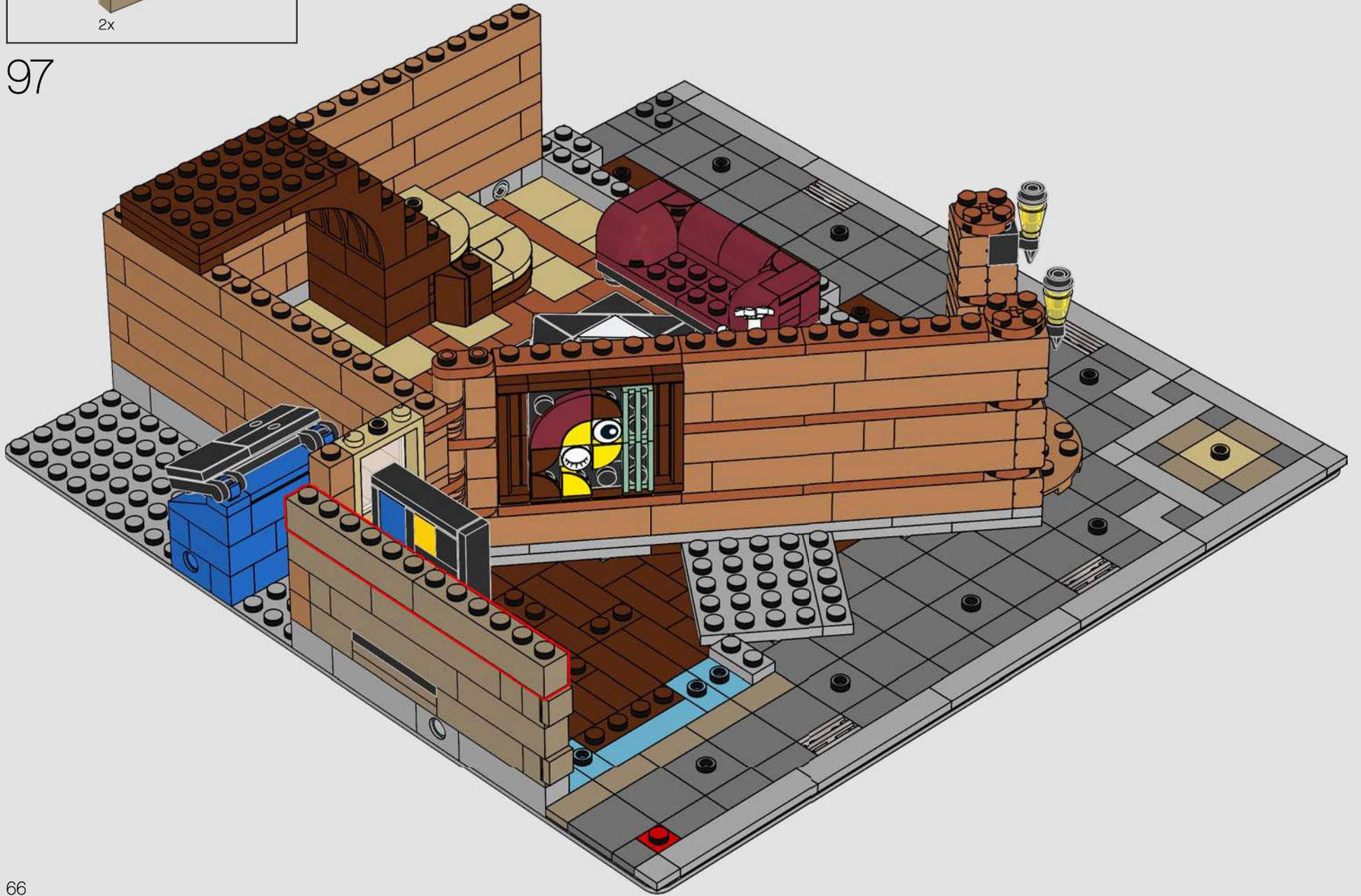

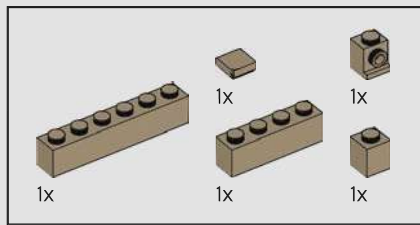

98

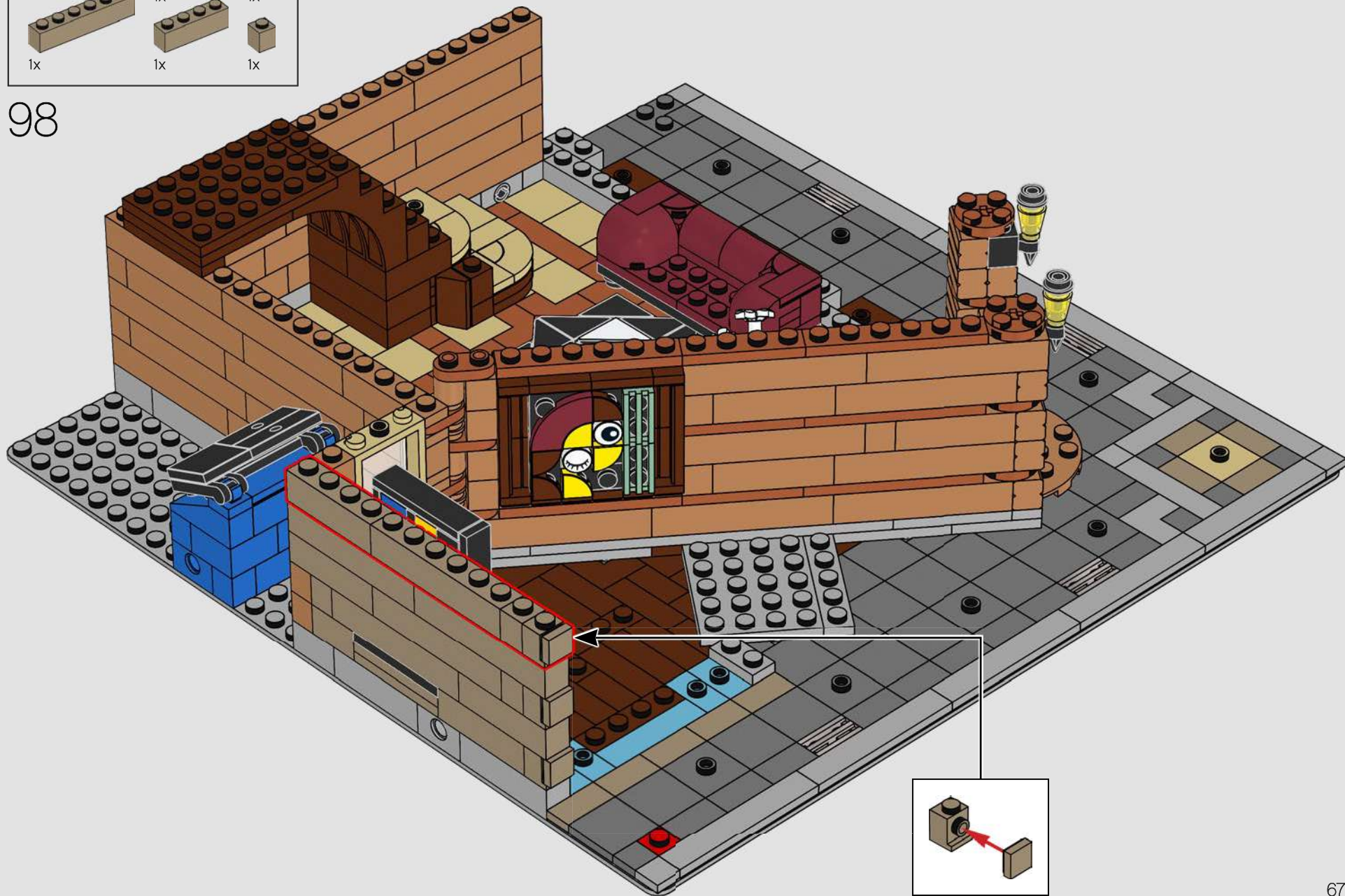

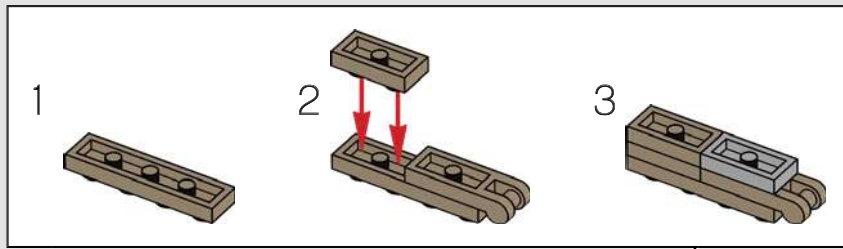
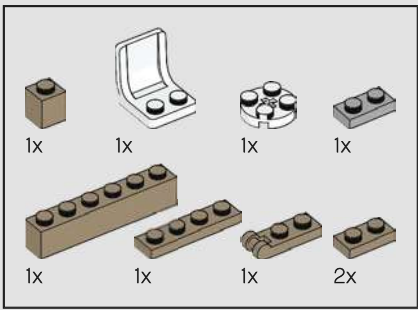

99



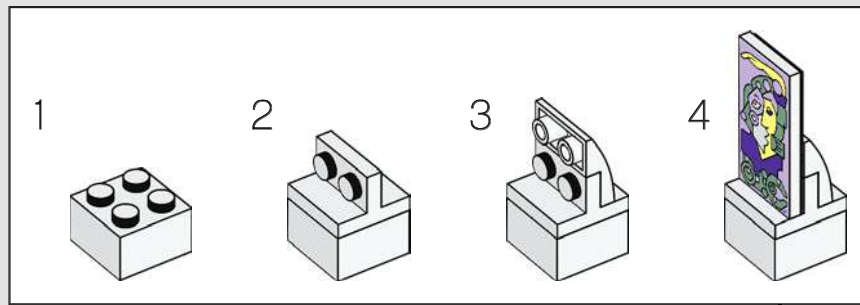
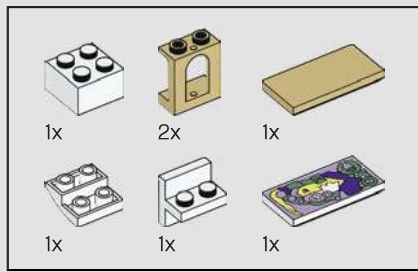

100

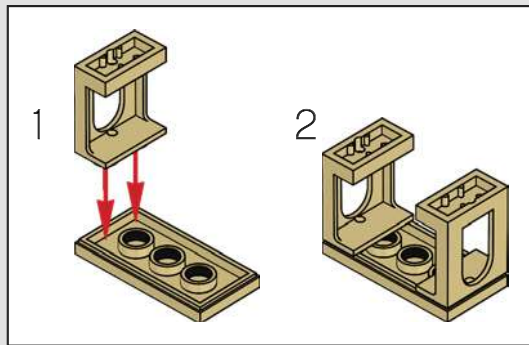

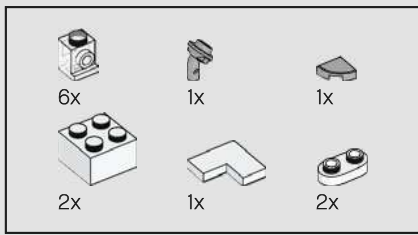

101

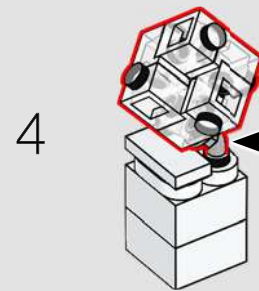
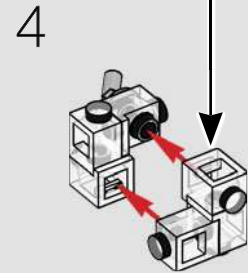
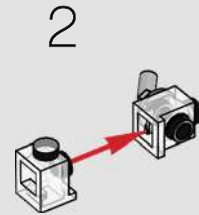
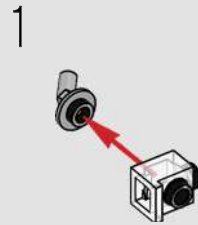
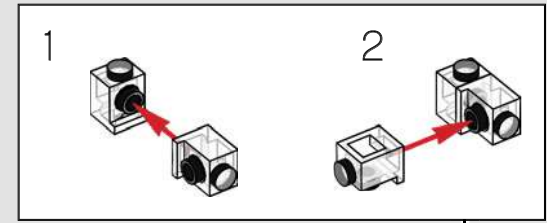
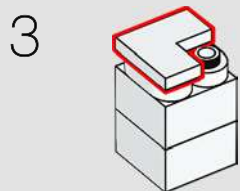
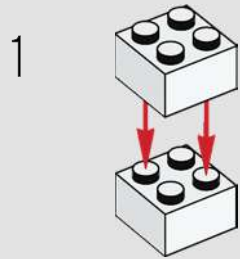

The Gallery Owner is very excited to debut her collection of Cubist Art! Her favourite piece, though, isn't Cubist – it's just an expertly made cube.

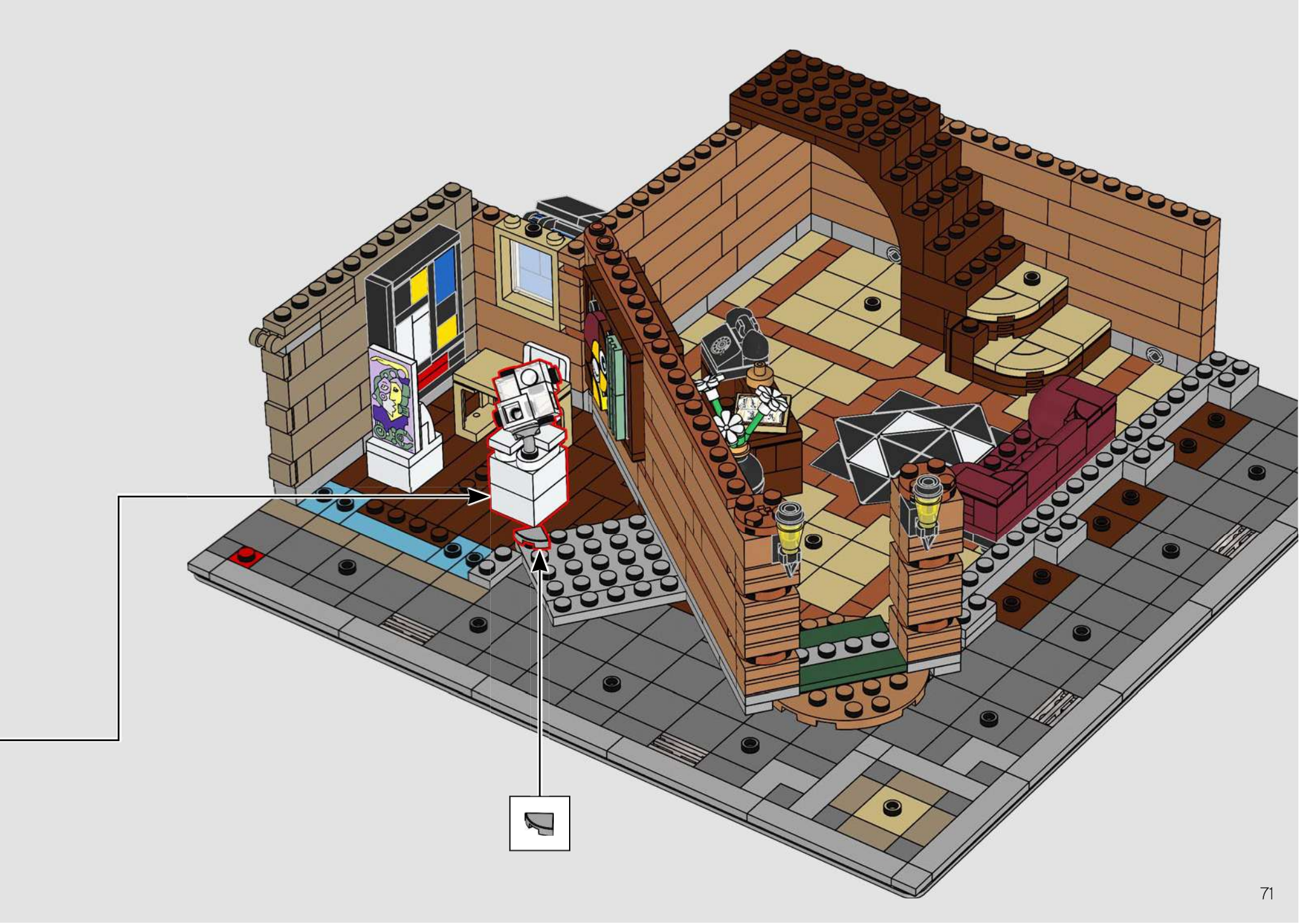

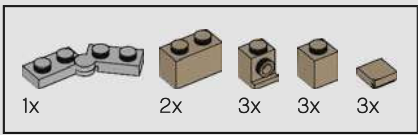

102

1

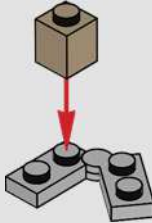

2

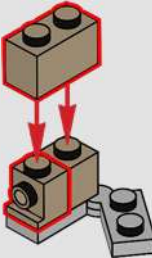

3

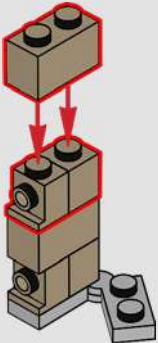

4

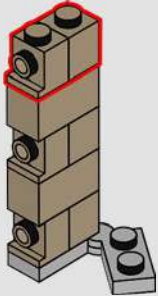

5

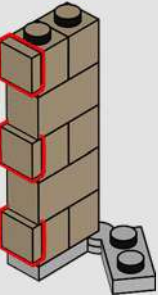

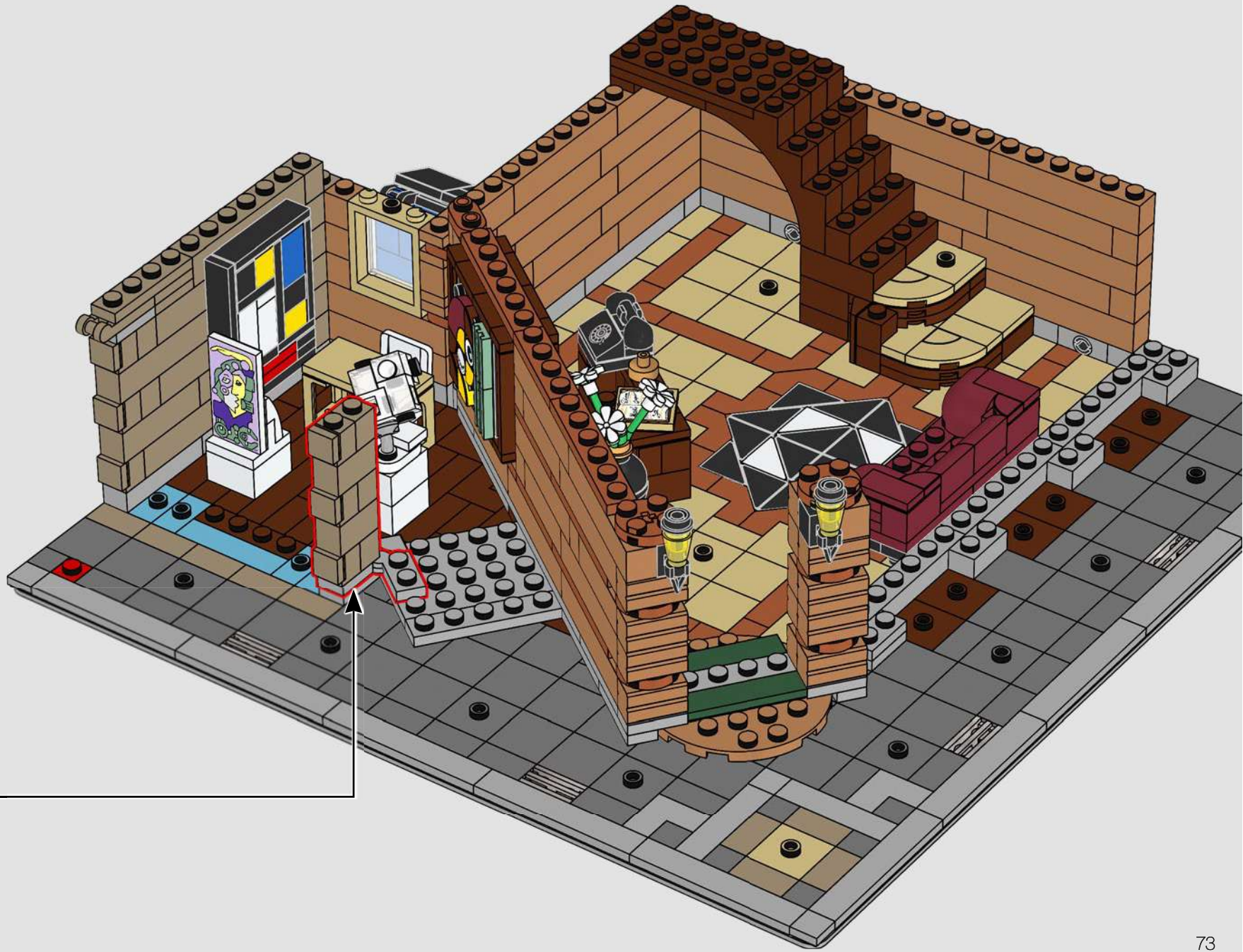

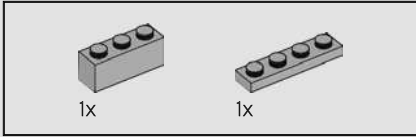
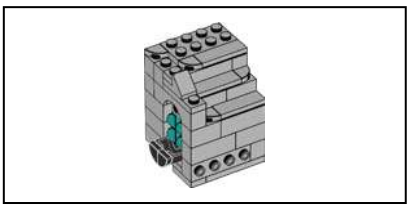

103

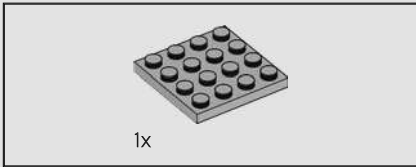
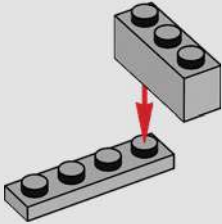

104

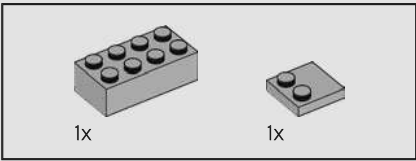
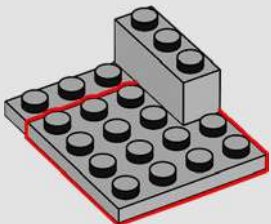

105

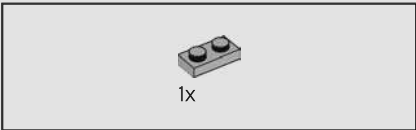
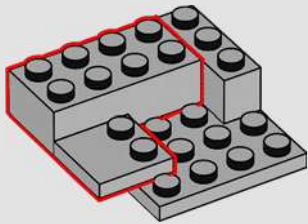

106

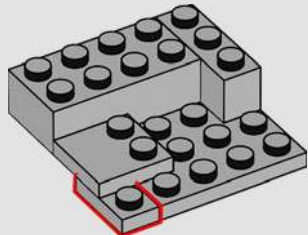

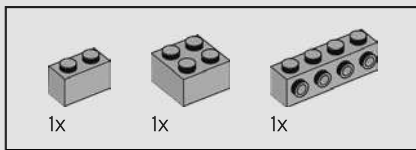

107

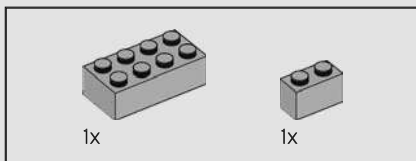
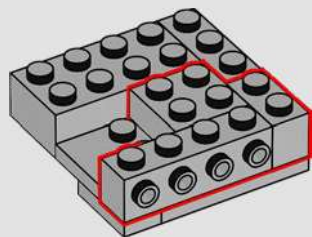

108

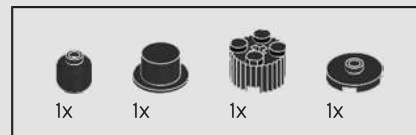
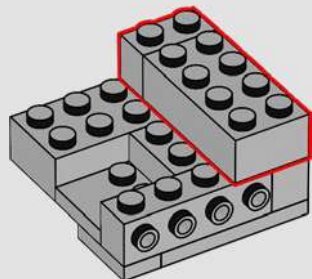

109

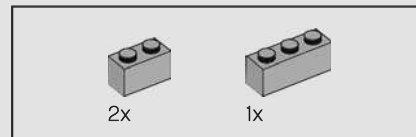
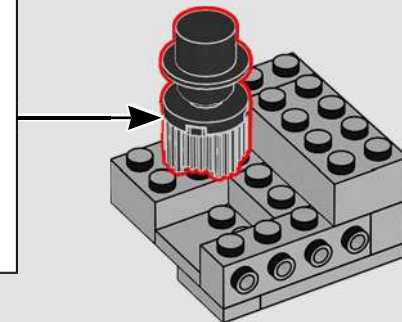
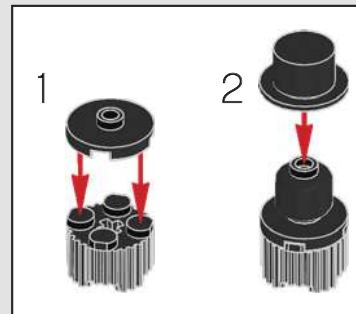

110

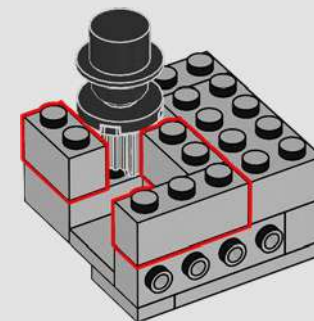

This bust is by the same artist who carved the white bust in the lobby of the 10224 Town Hall set.

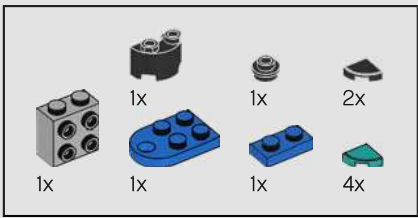

111

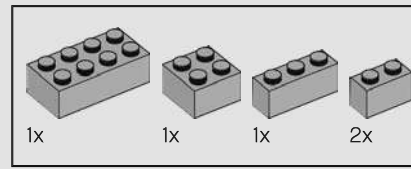
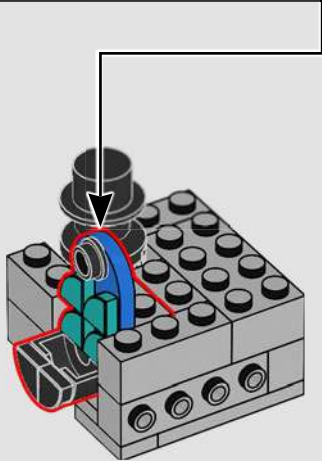
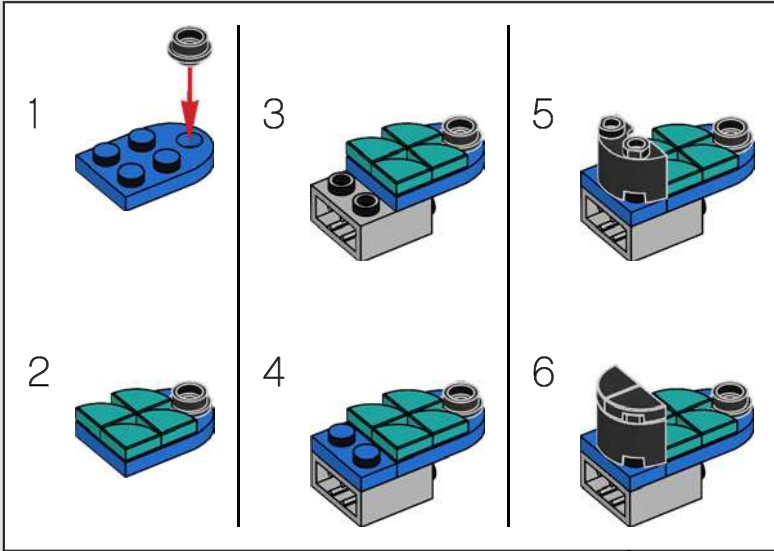

112

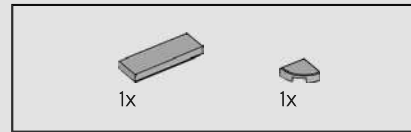
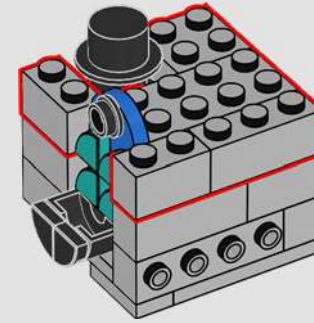

113

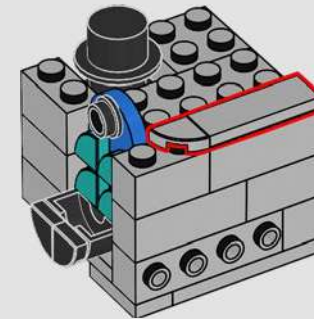

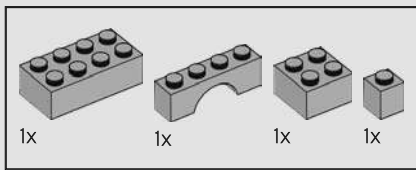

114

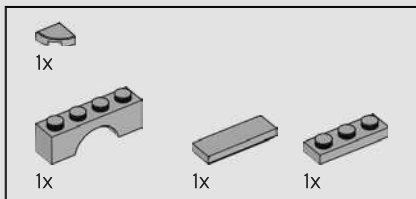
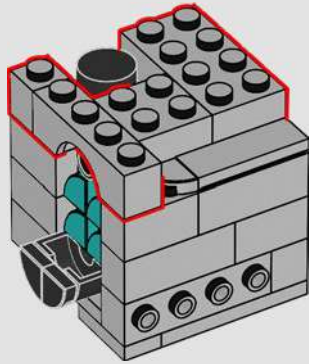

115

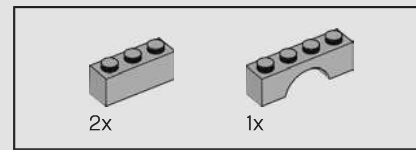
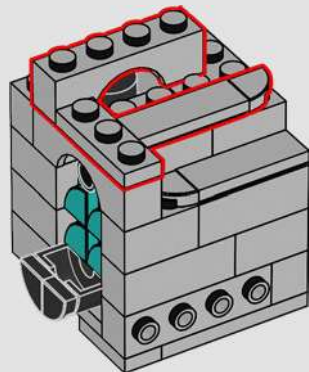

116

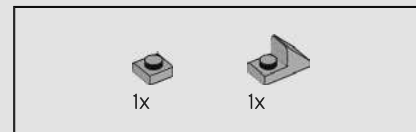
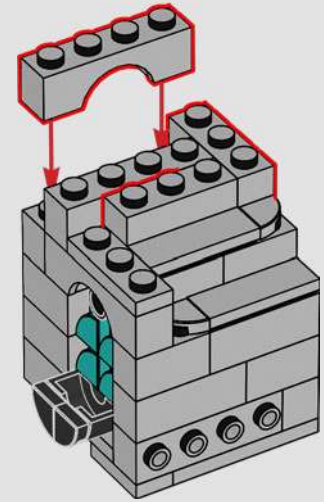

117

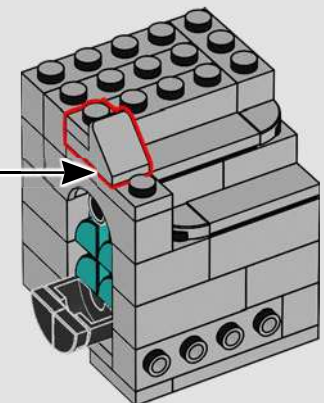
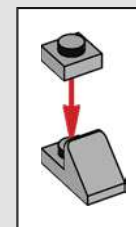

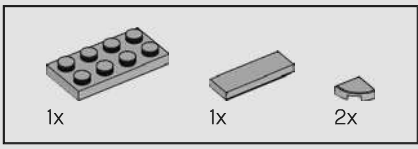

118

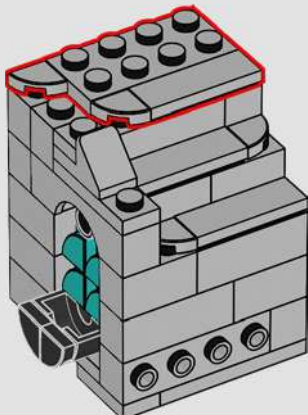

119

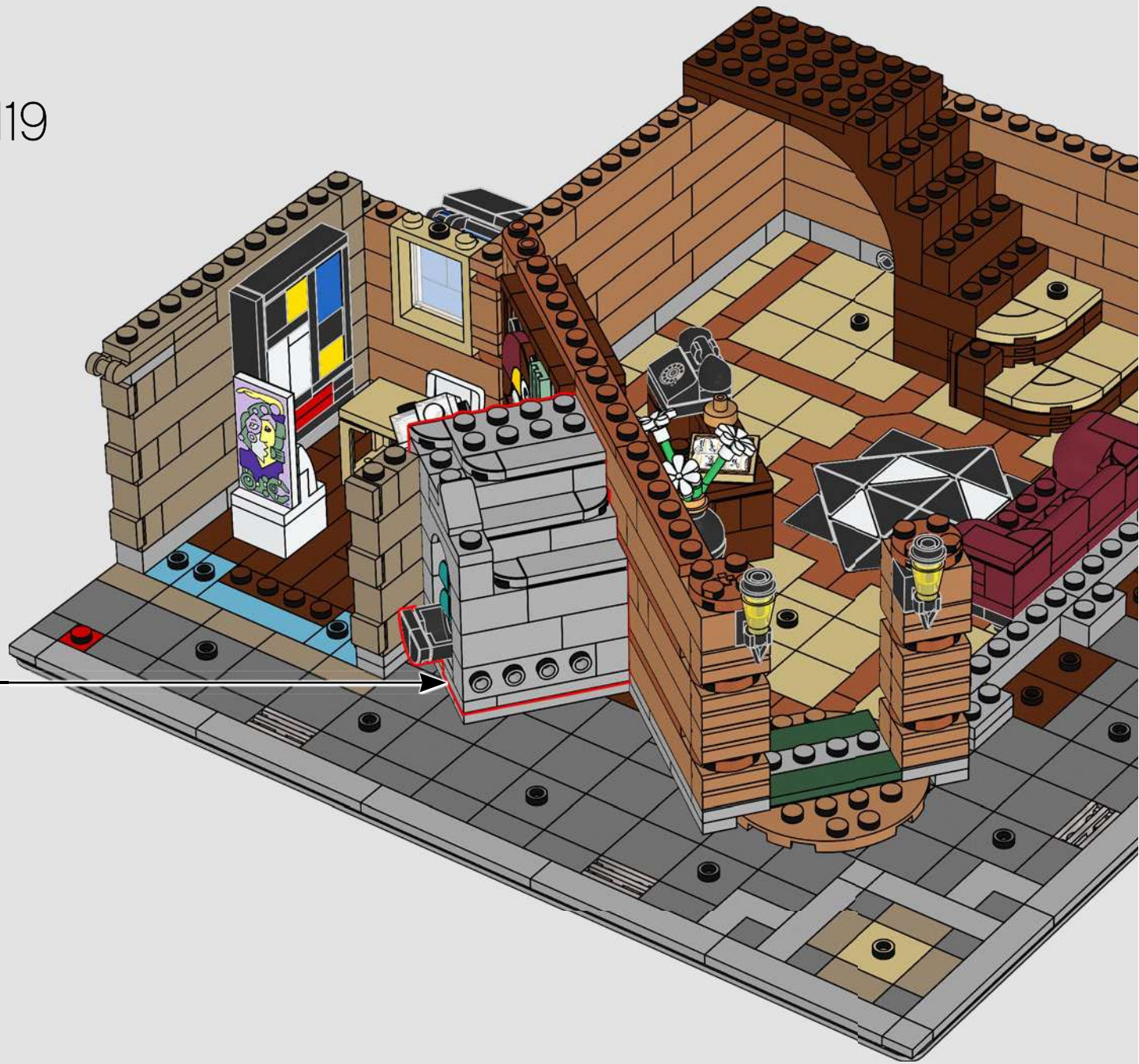

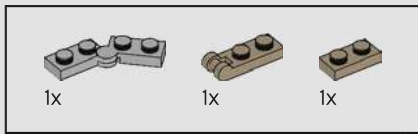

120

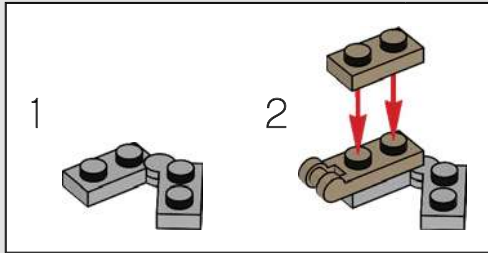

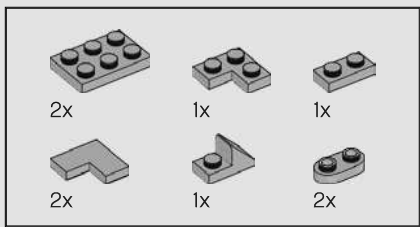

121

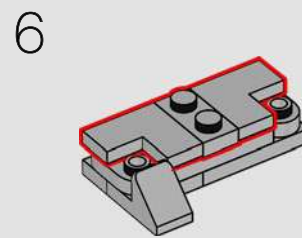
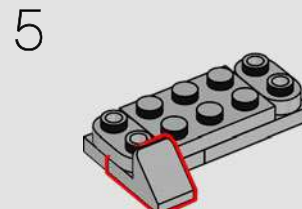
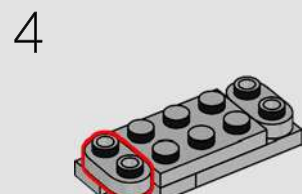
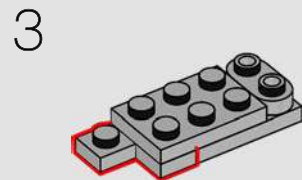
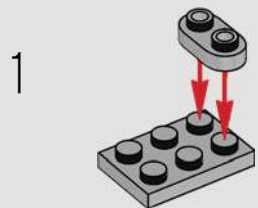

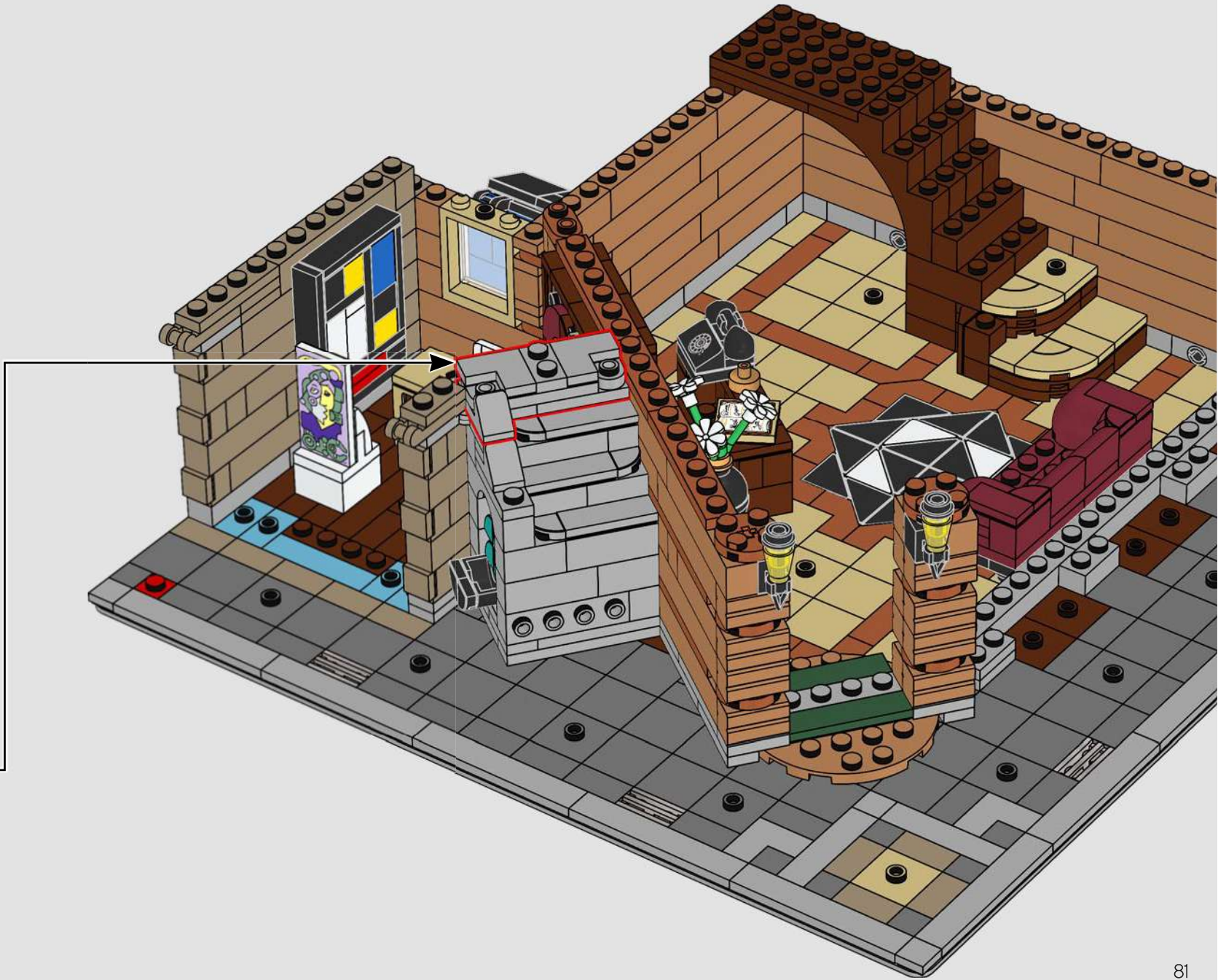

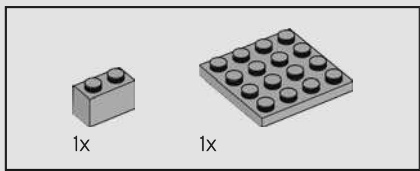

122

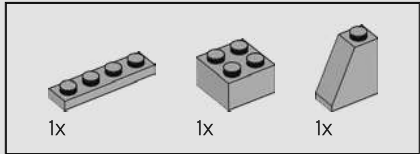
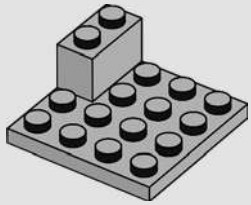

123

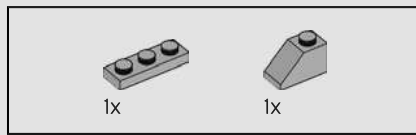
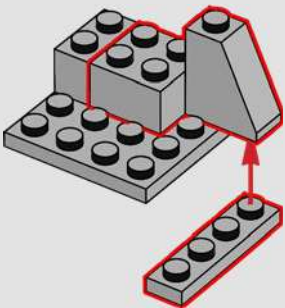

124

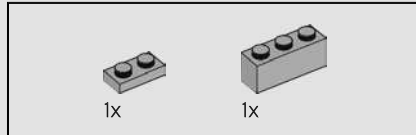
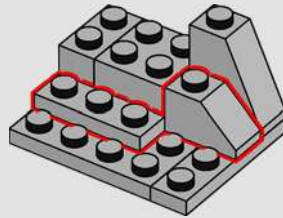

125

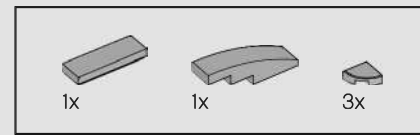
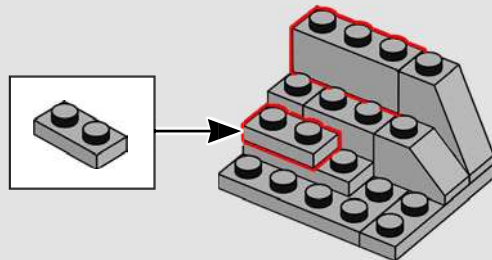

126

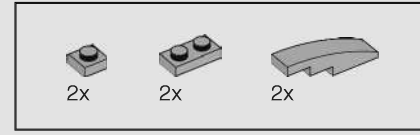
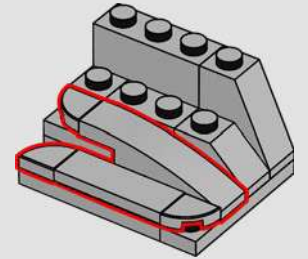

127

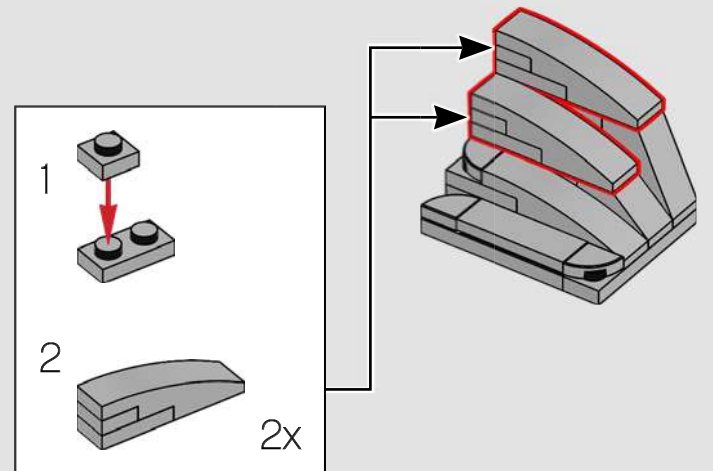

128

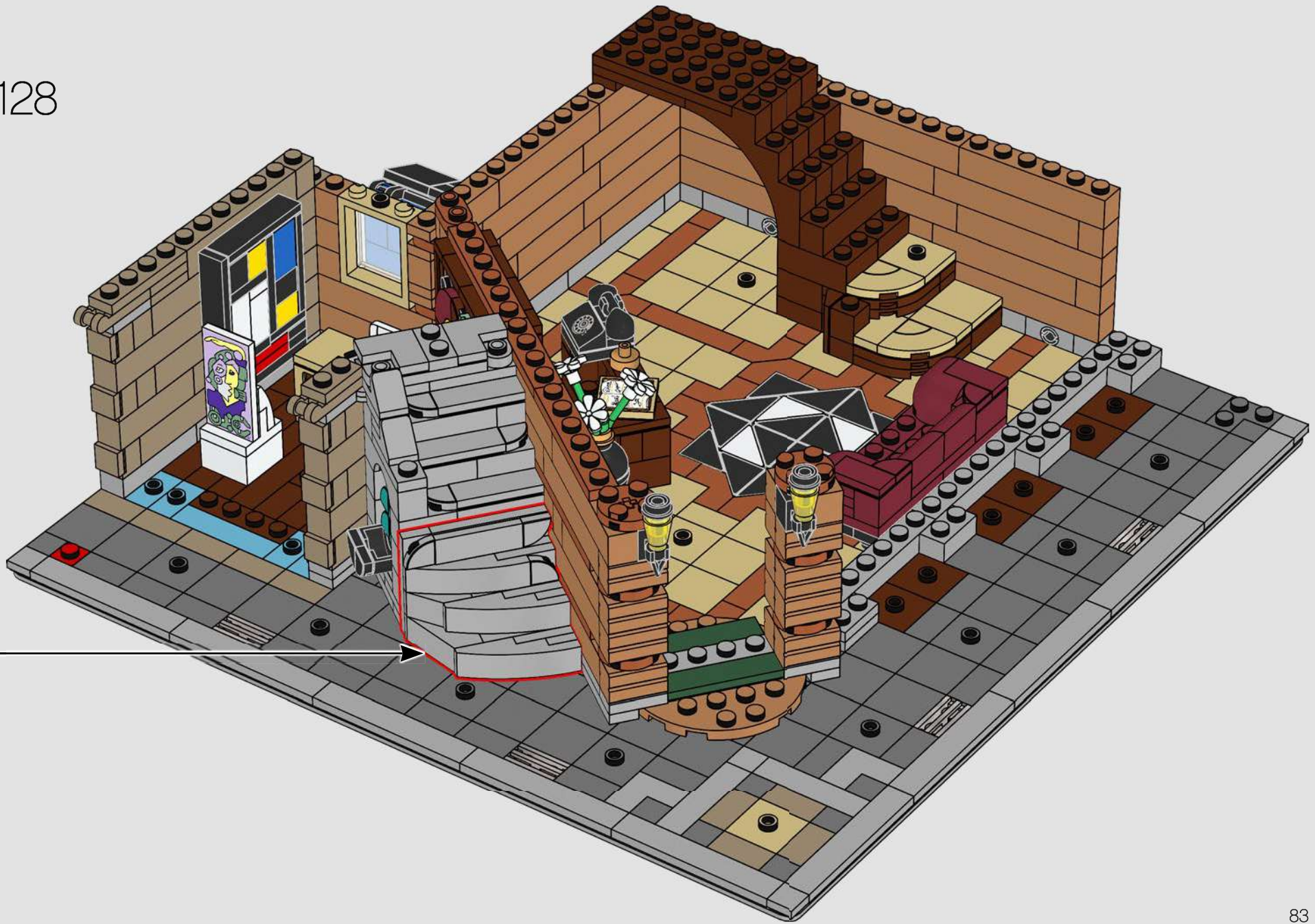

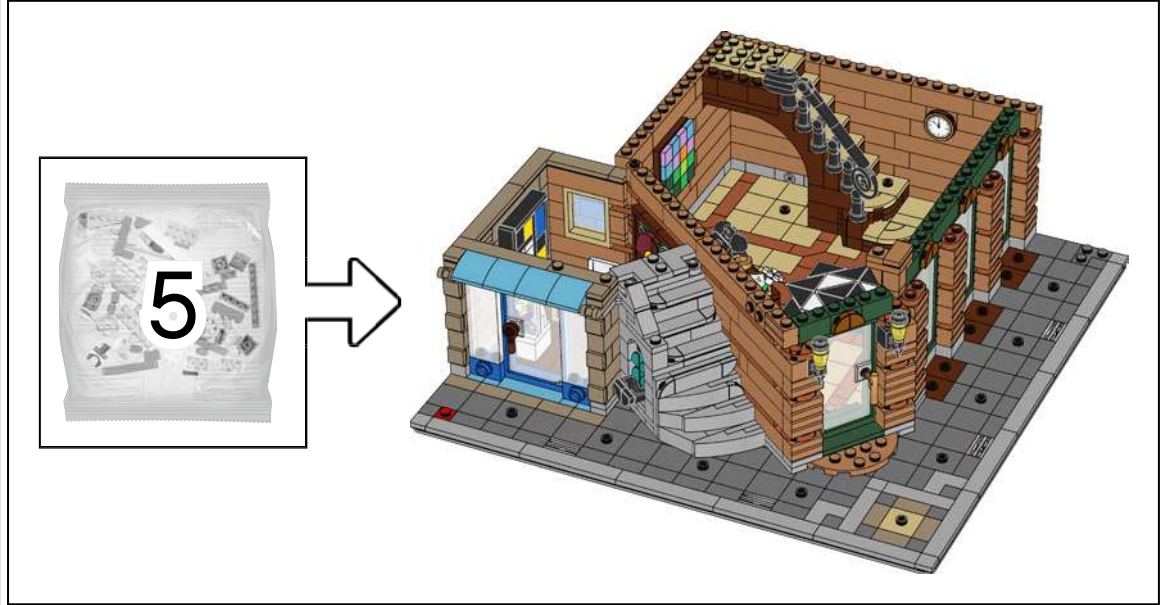

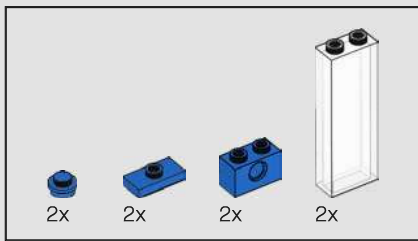

129

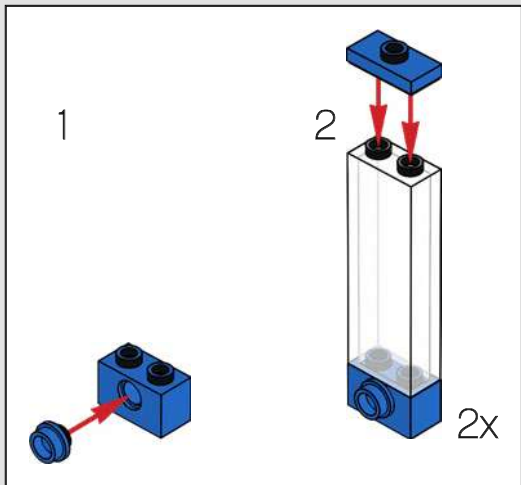

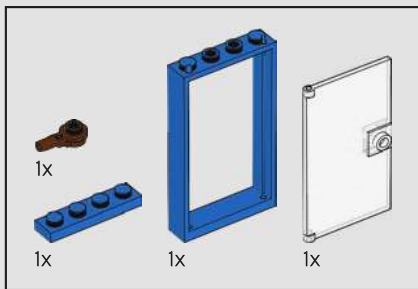

130

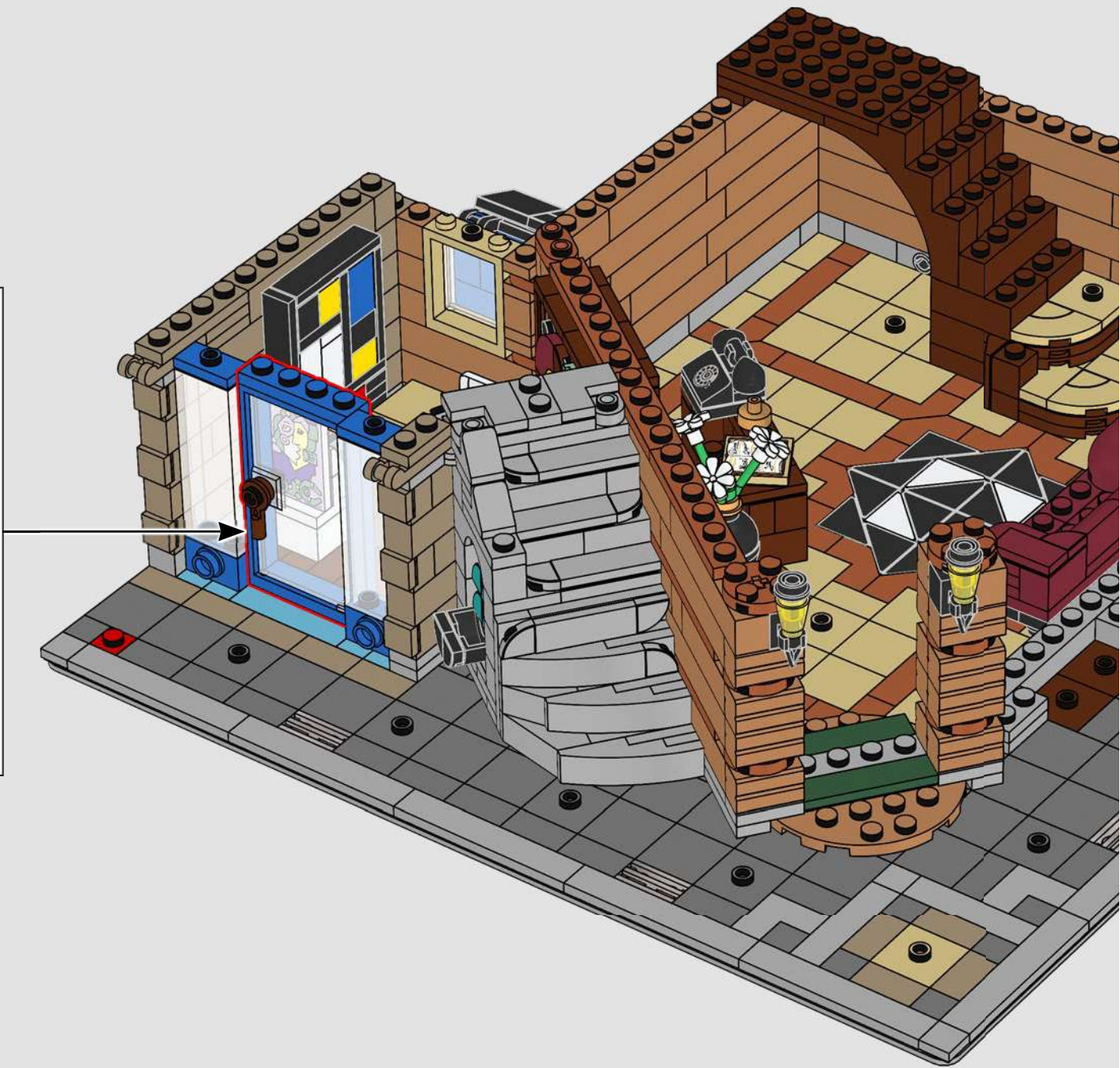
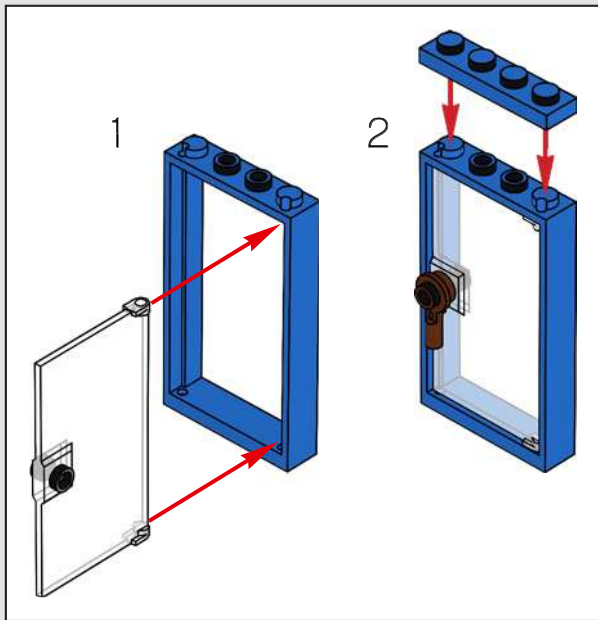

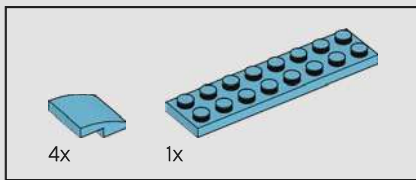

131

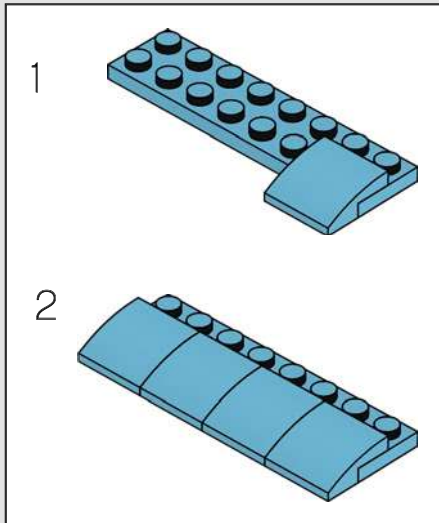

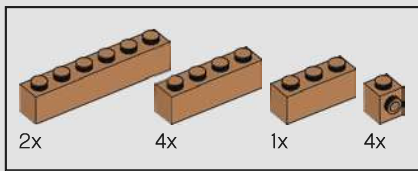

132



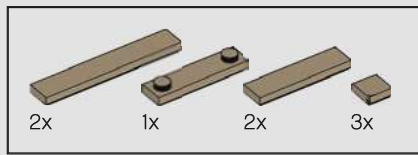

133



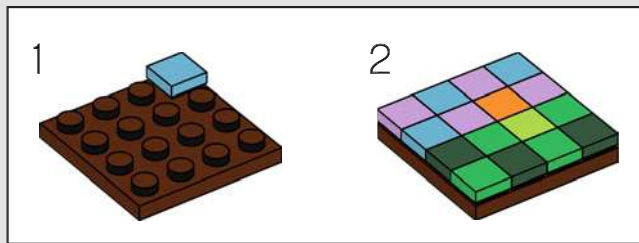
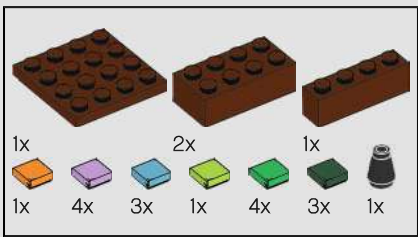

This painting is by the Artist whose studio is in the loft of the 10243 Parisian Restaurant set.

134



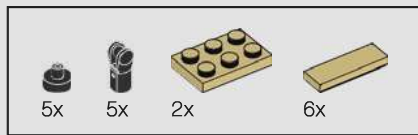

135

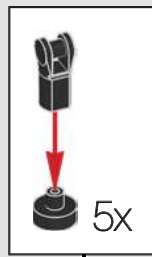



136

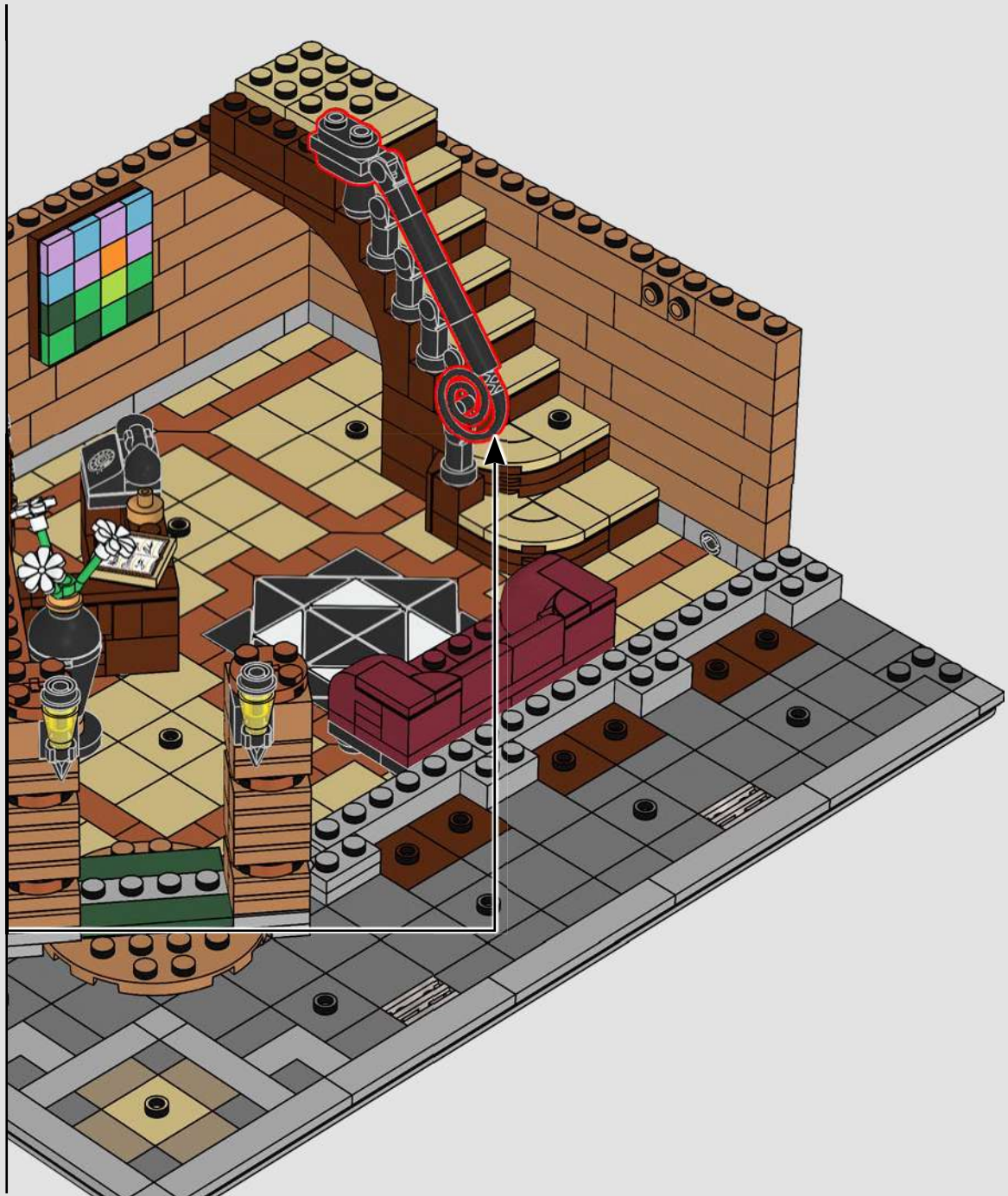
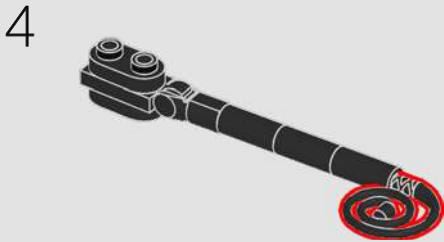
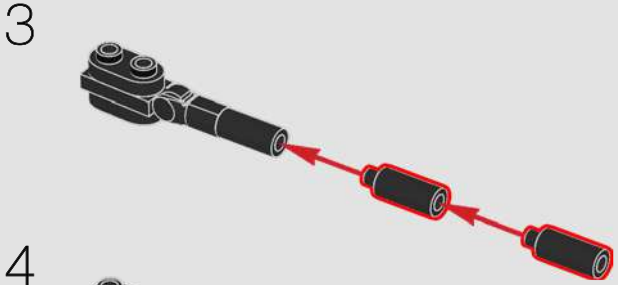
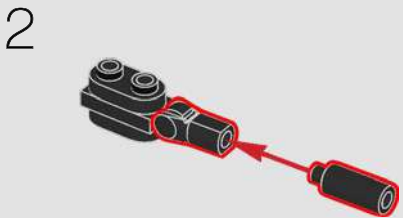
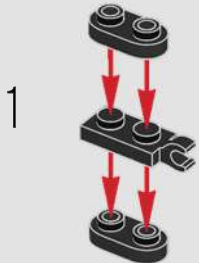

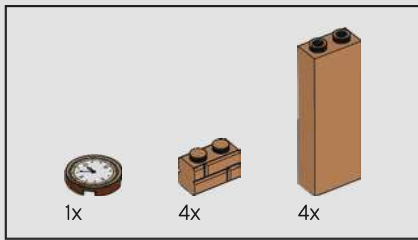

137

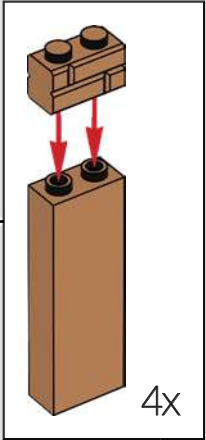

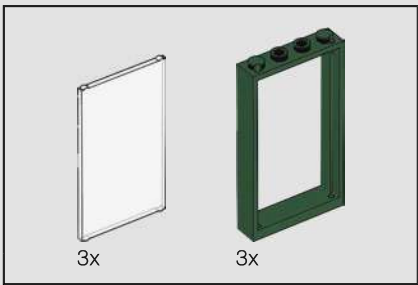

138

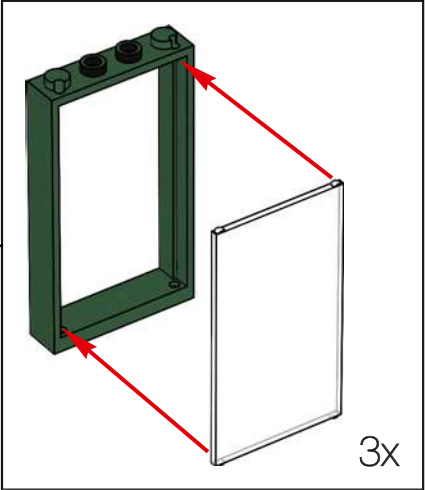

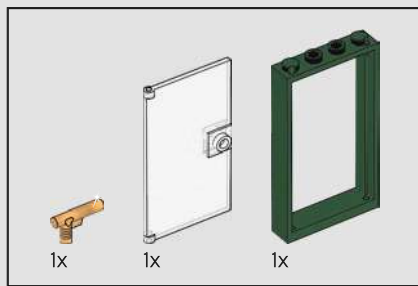

139

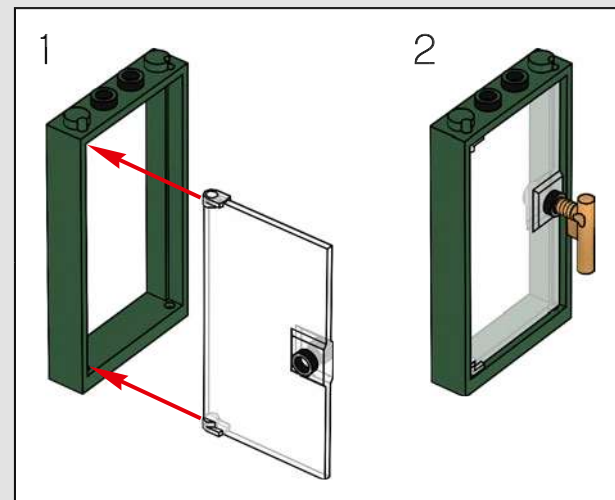

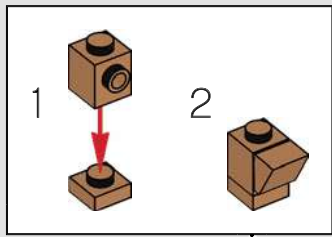
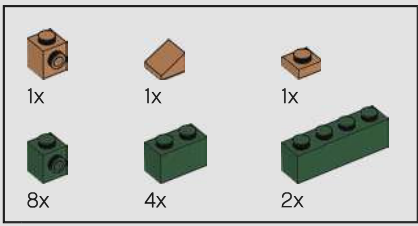

140





141



-  12x
-  20x
-  1x
-  1x
-  1x

142

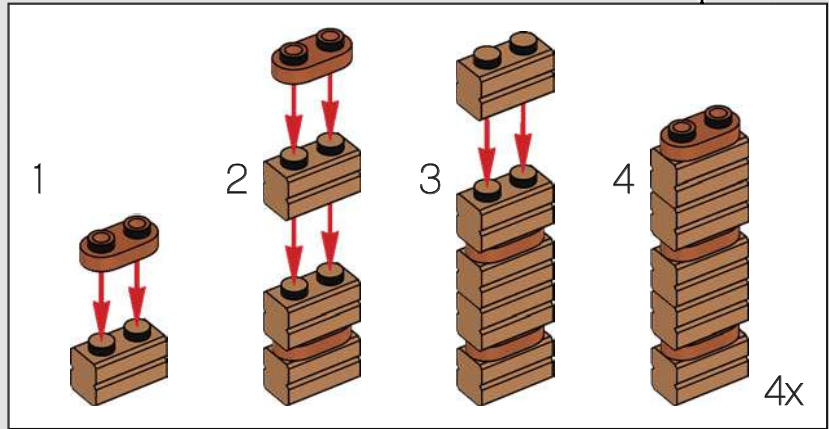
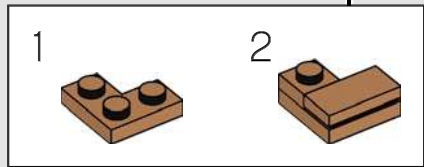

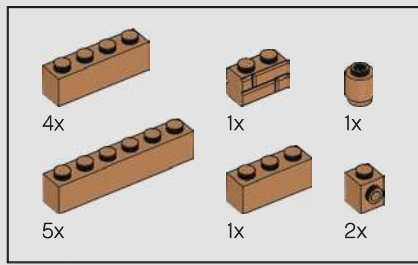

143



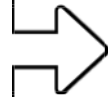

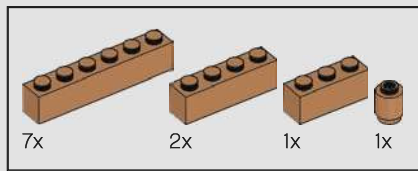

144



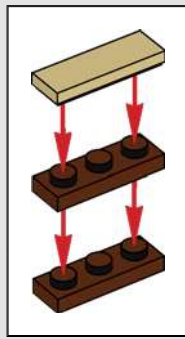
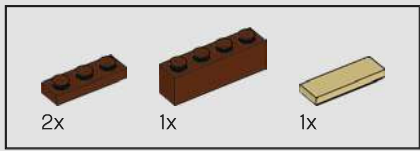

145



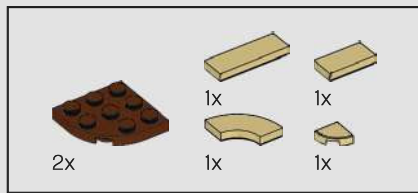

146

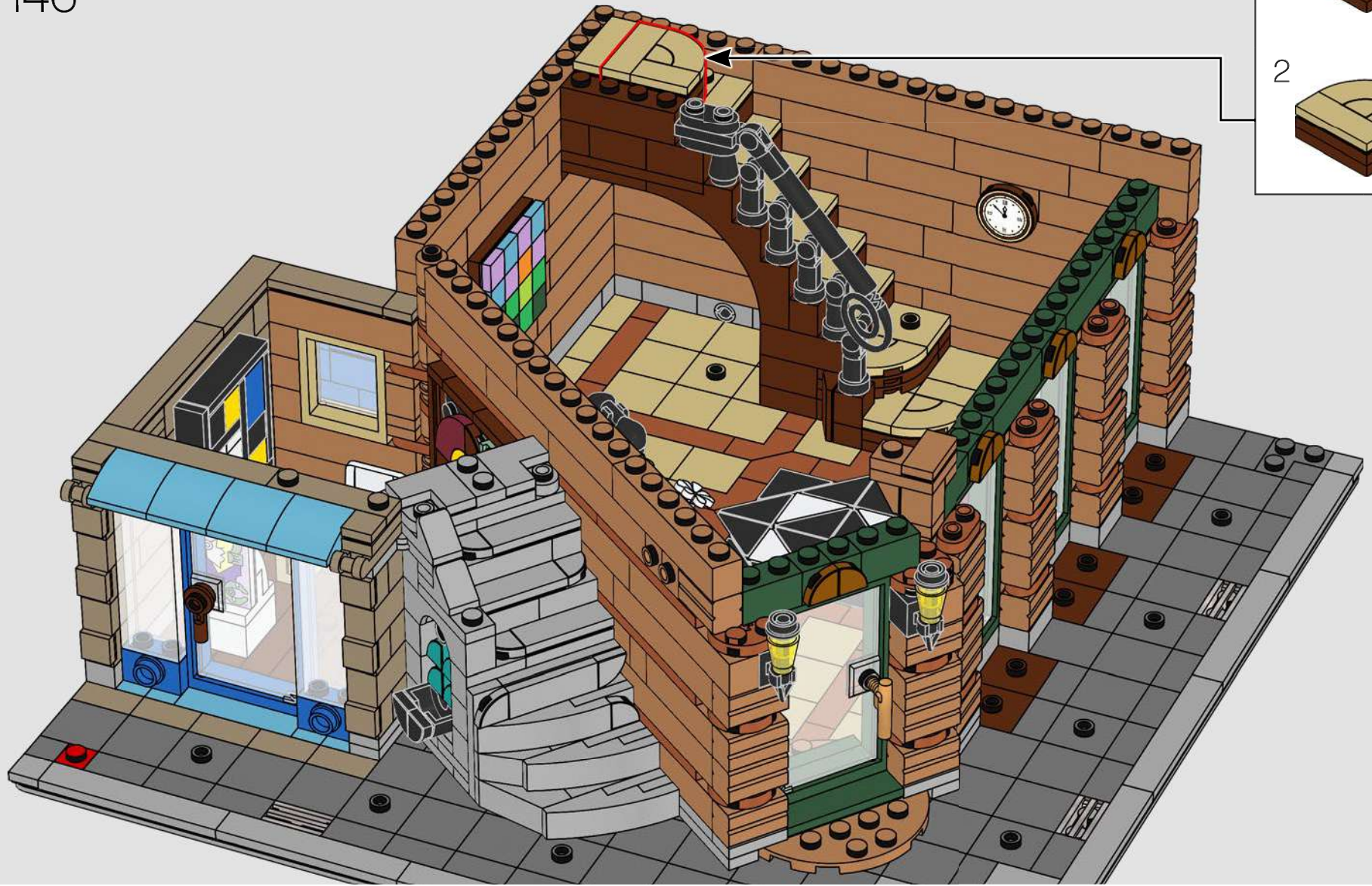
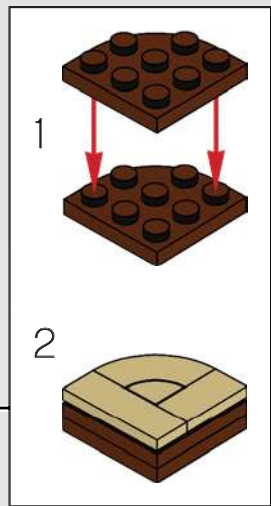

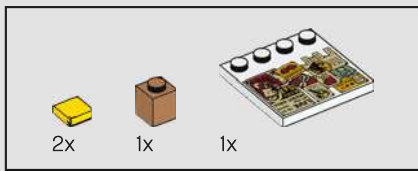

147

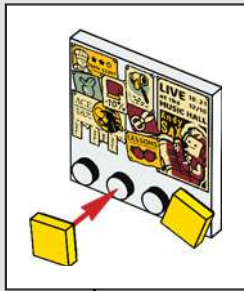

The posts on this Notice Board all advertise goods and services from elsewhere in previous Modular sets. See if you can recognise the references!

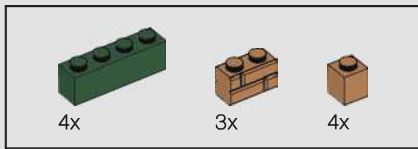

148

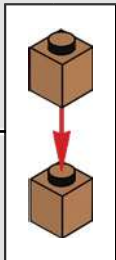

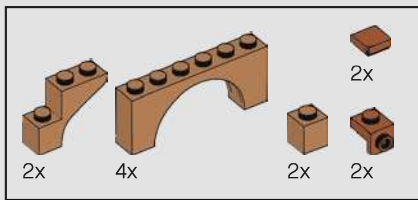

149

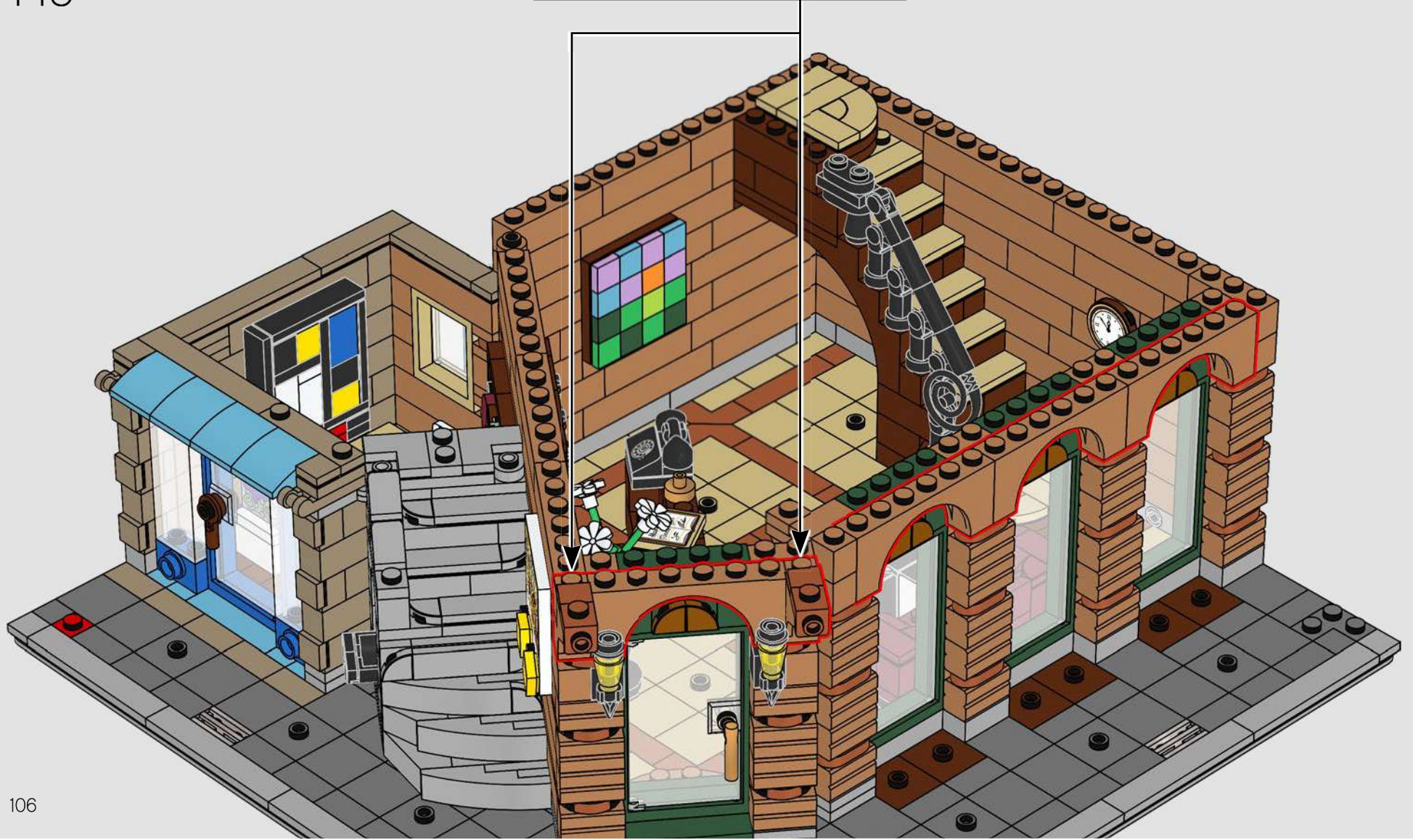
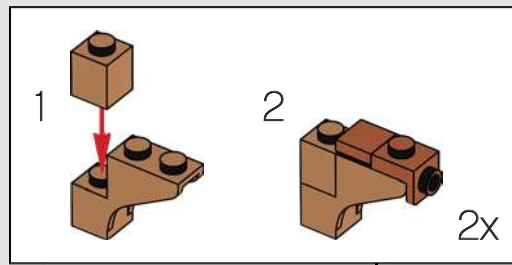

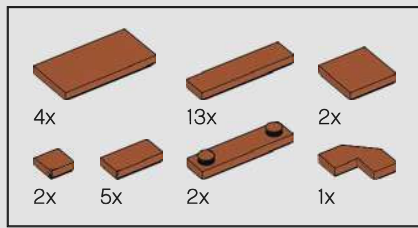

150



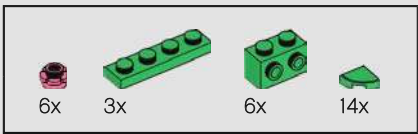

151

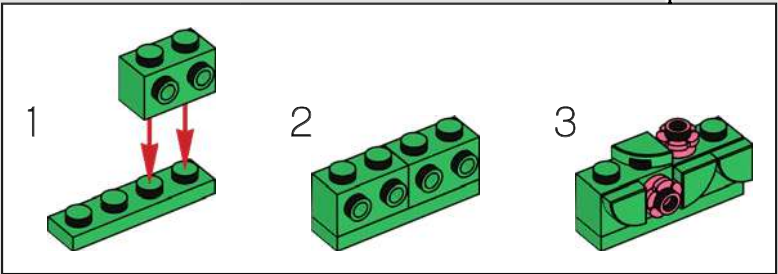
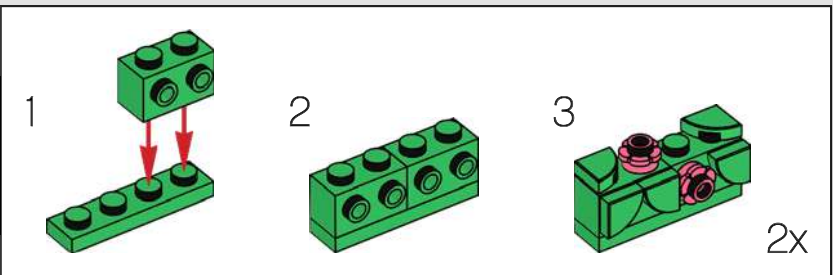

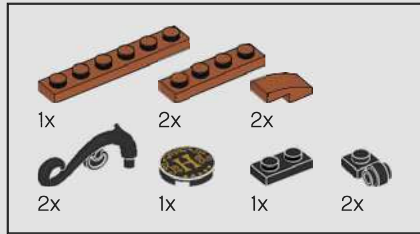

152

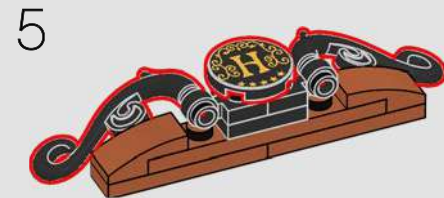
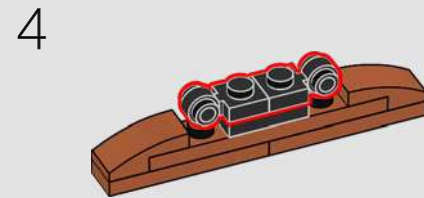
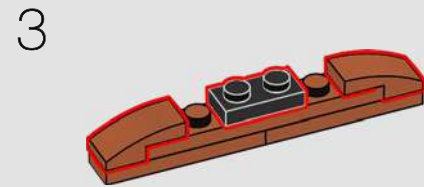
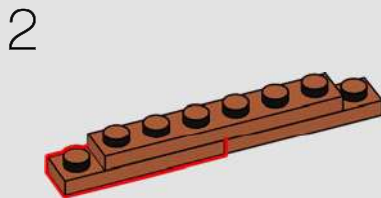
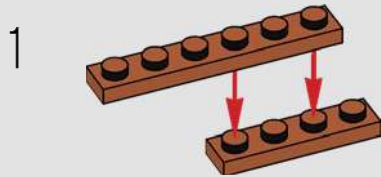



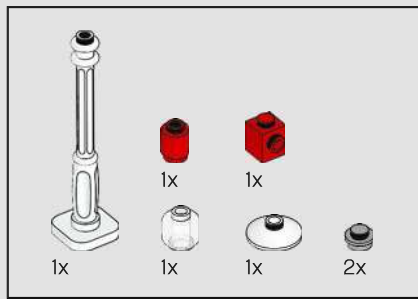

153

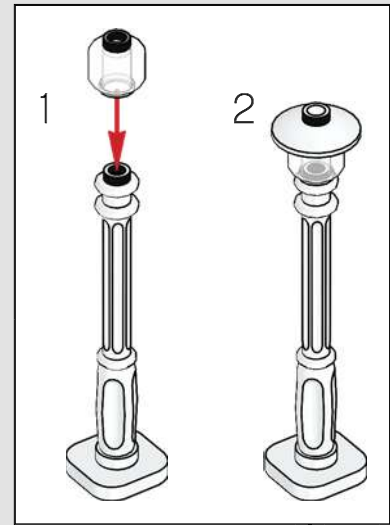
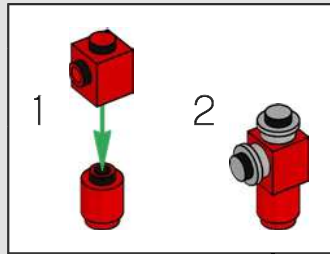

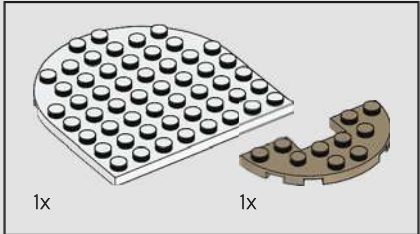
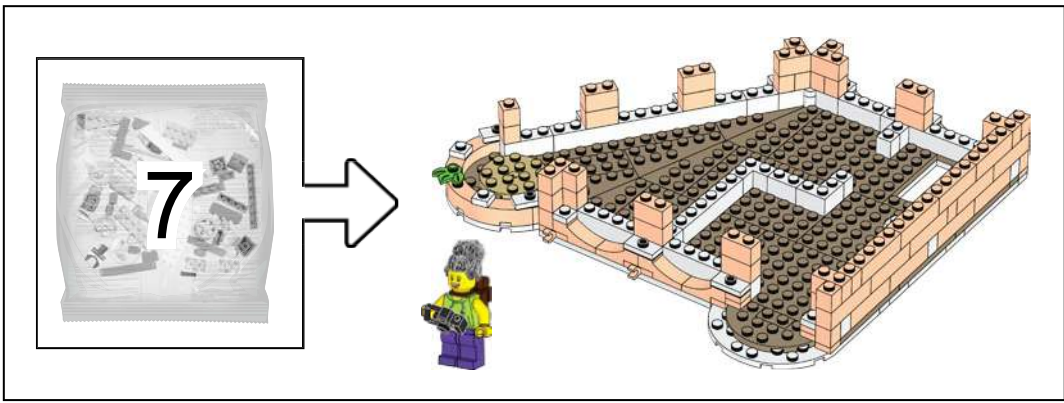

154

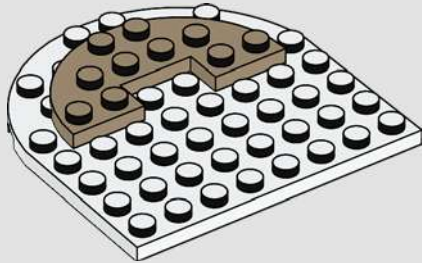

The Backpacker is travelling the world!
She's doing it on a budget, so is staying
in the Hotel's Economy room.

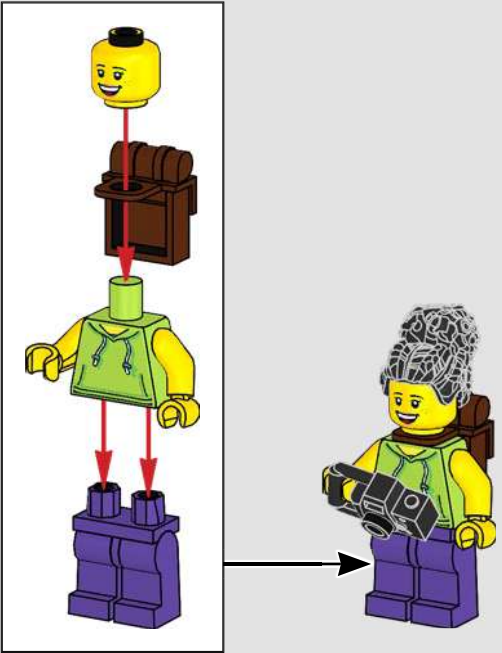

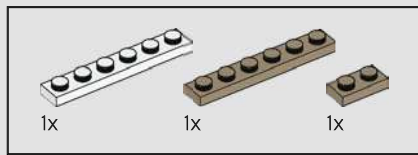

155

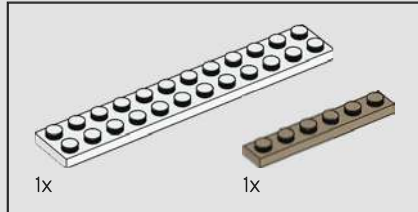
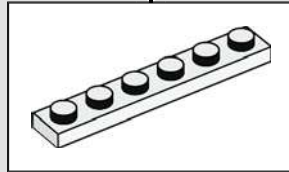
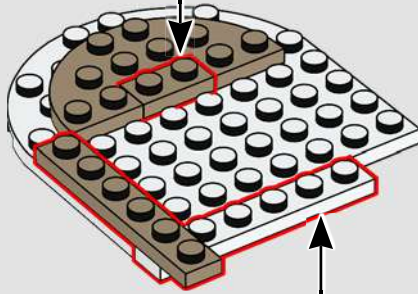
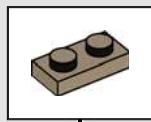

156

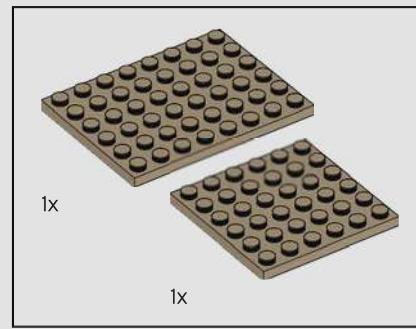
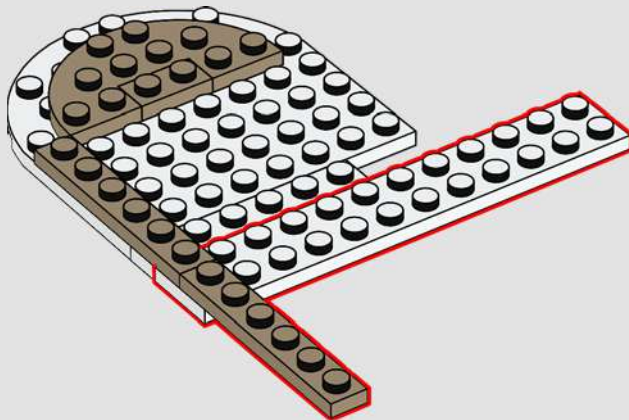

157

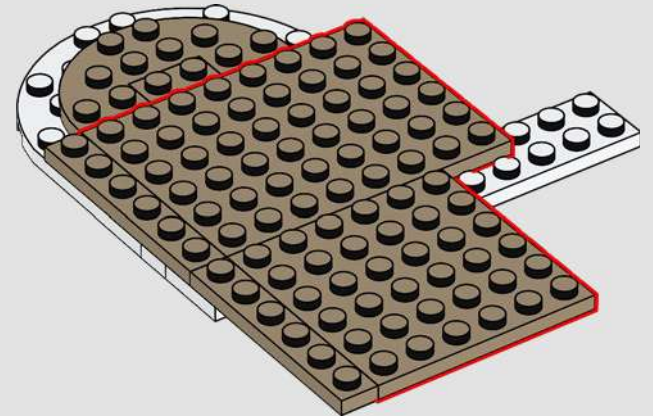



158

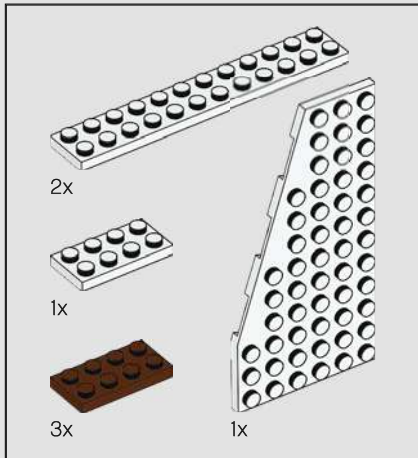
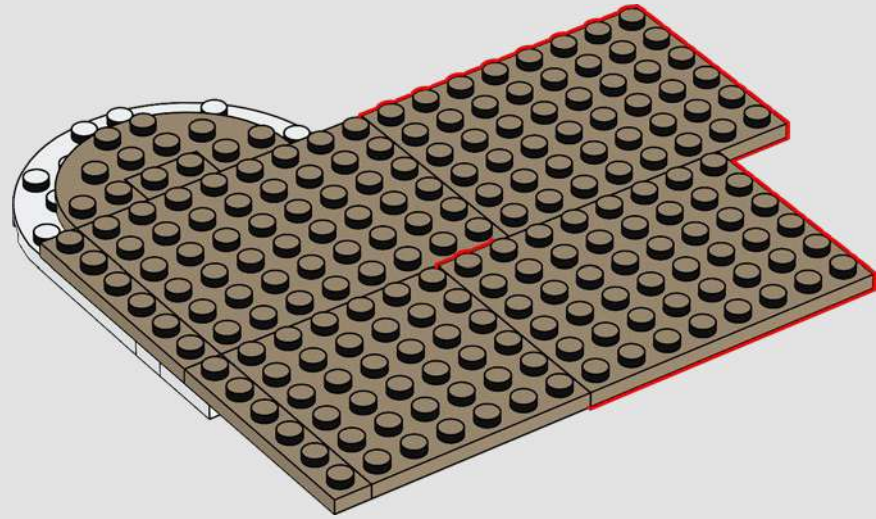

159

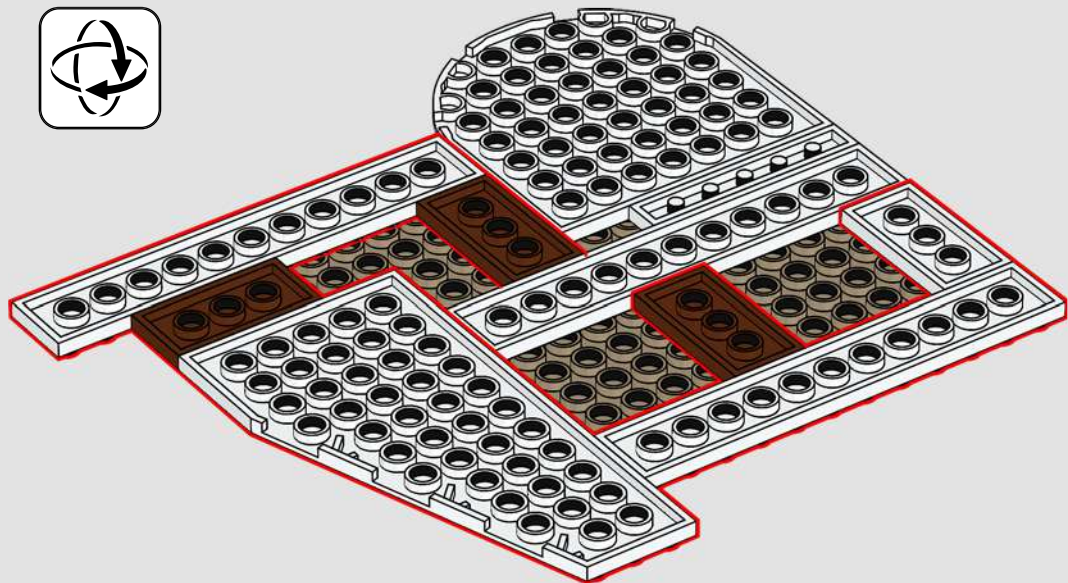

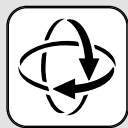
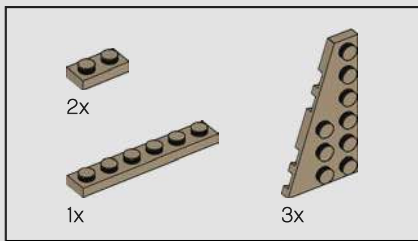

160

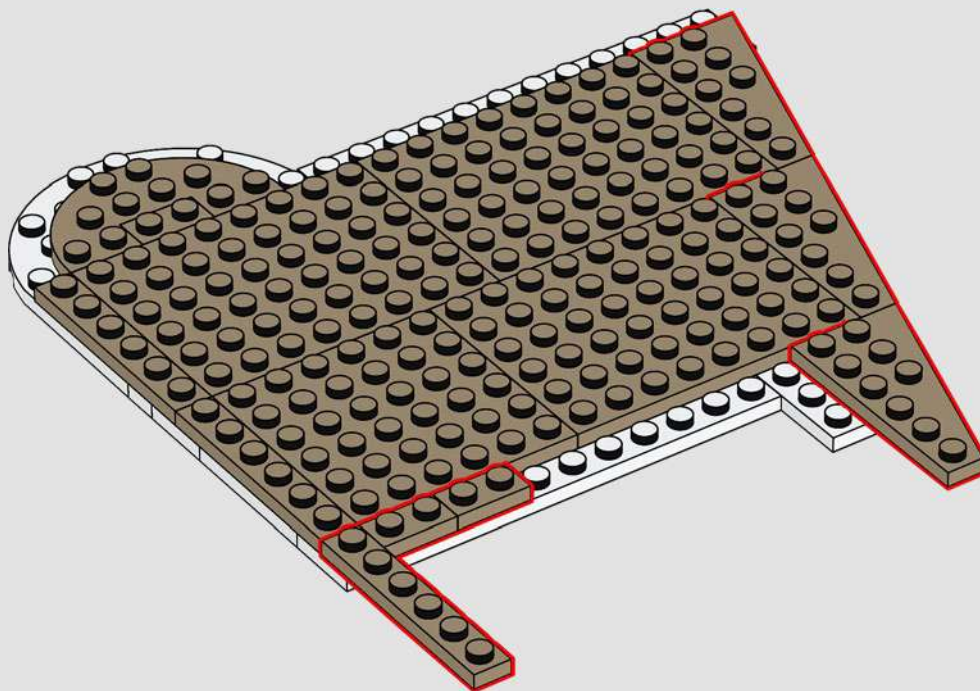

161

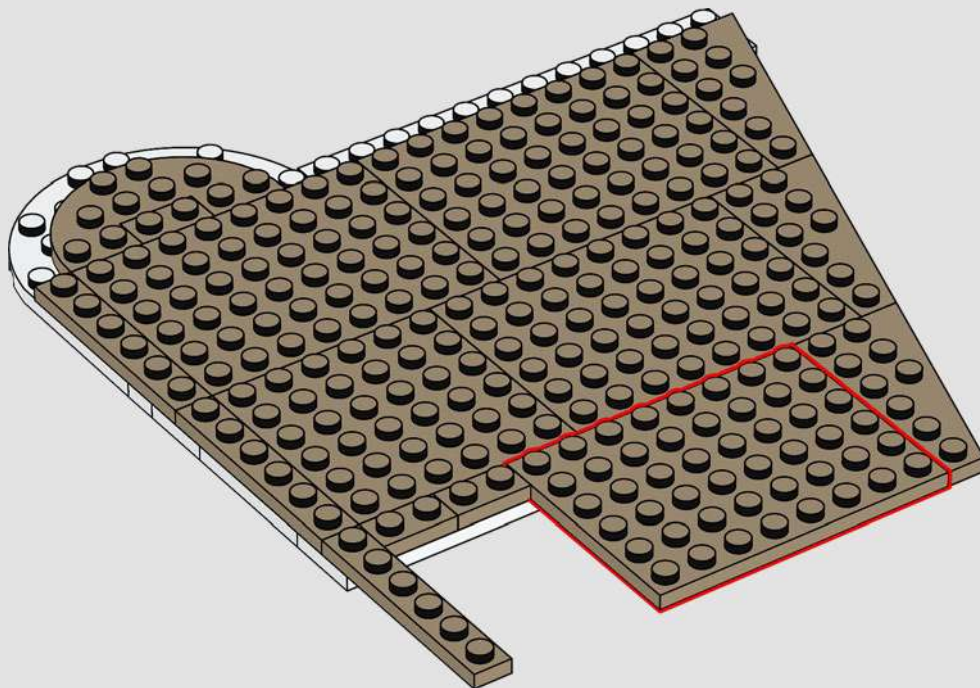

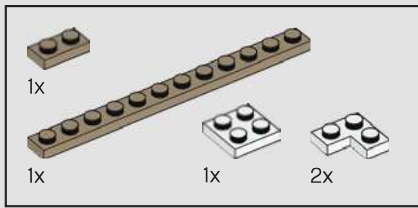

163

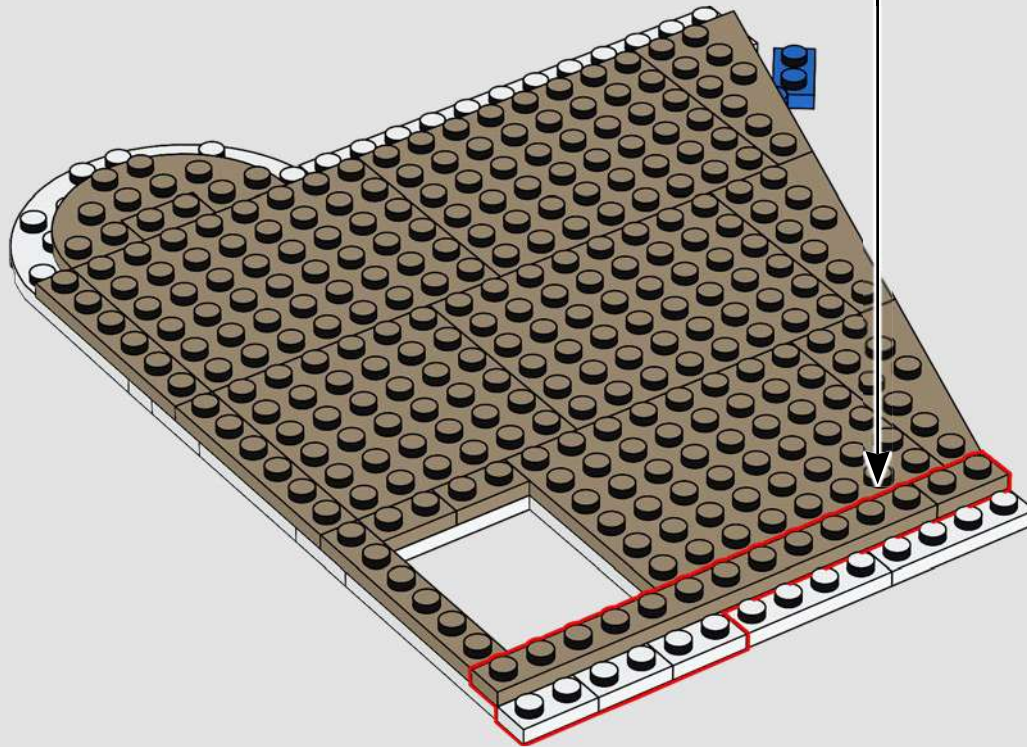
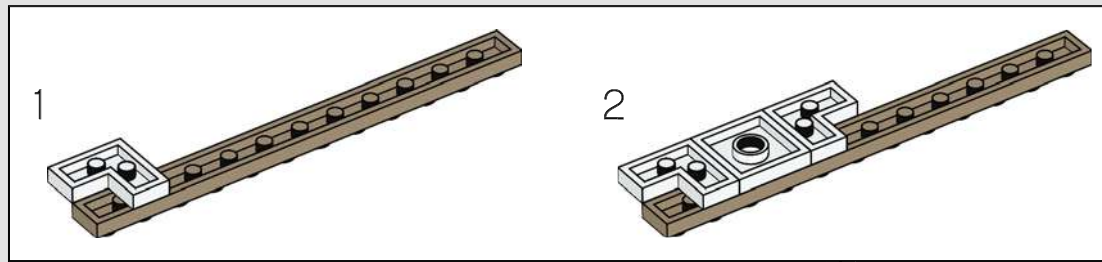

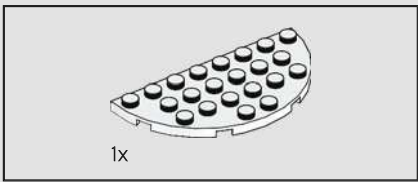

1x

164

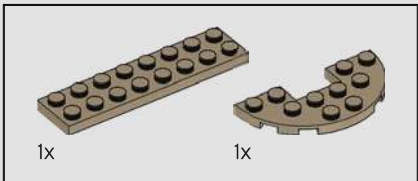
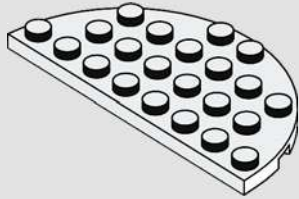

1x

1x

165

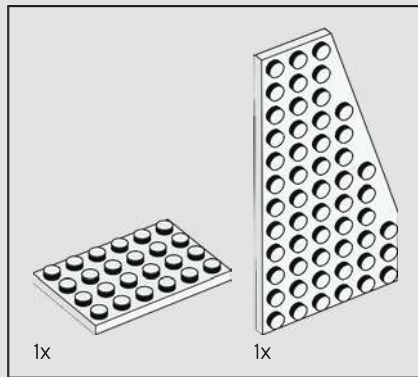
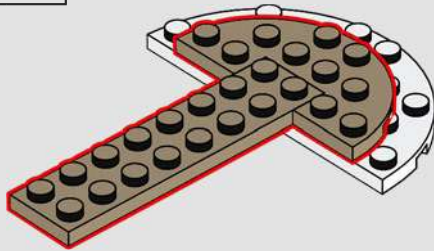

1x

1x

166

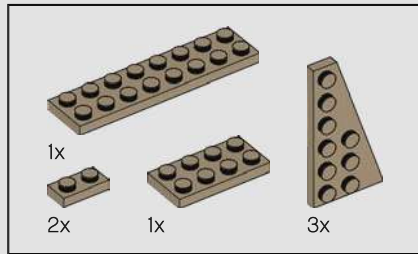
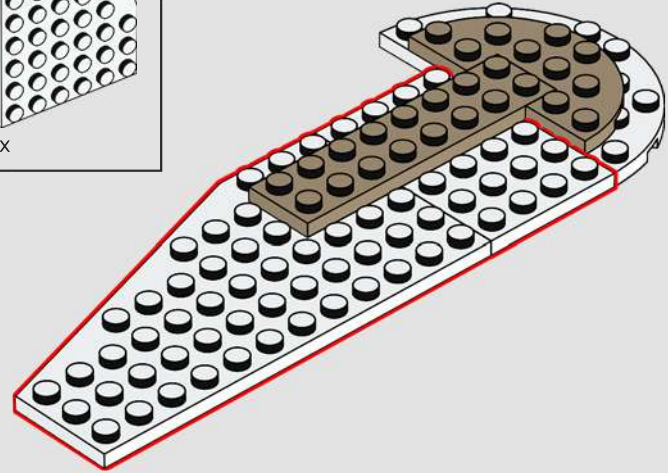

1x

2x

1x

3x

167

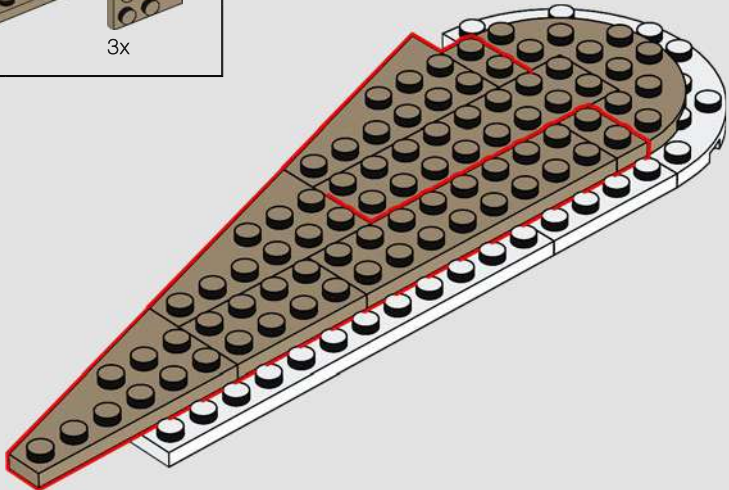

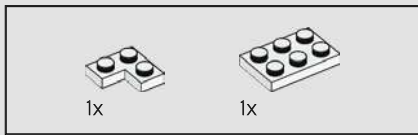

168

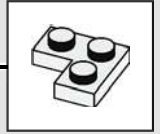
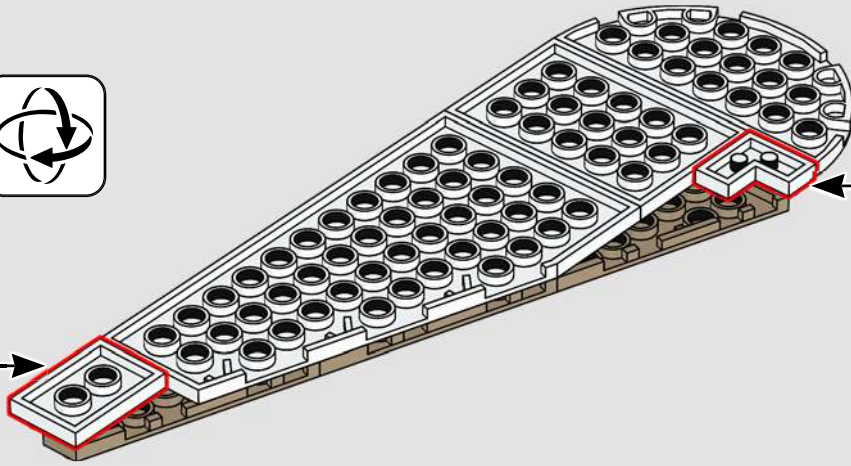
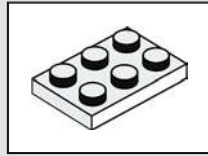

169

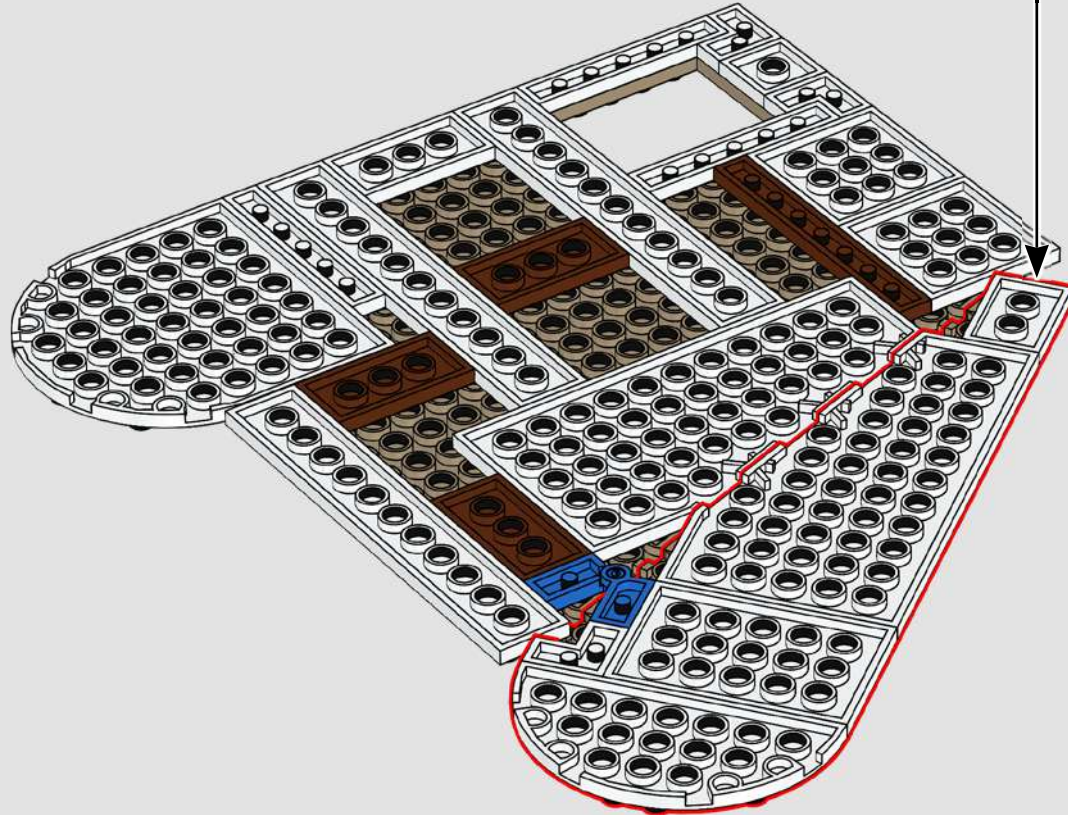

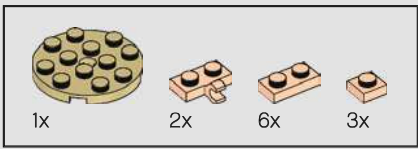

170

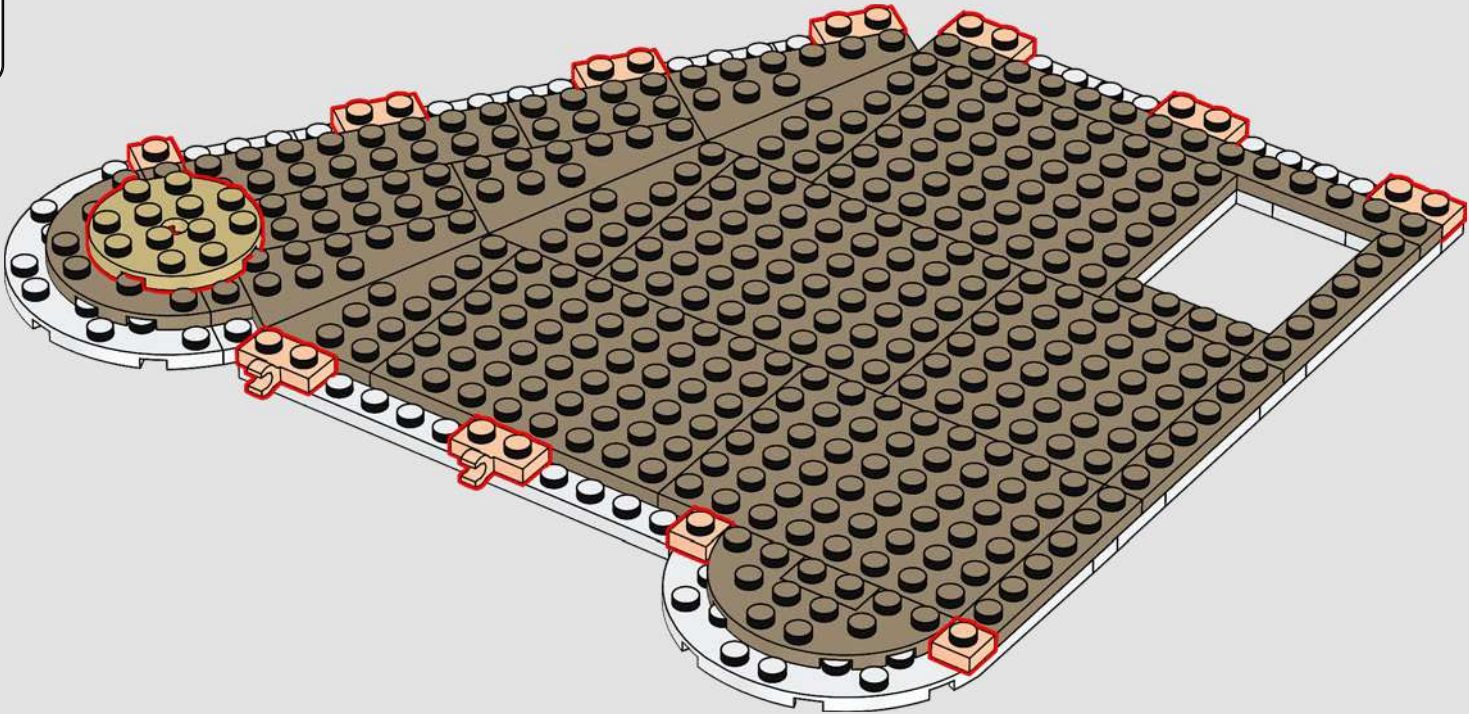

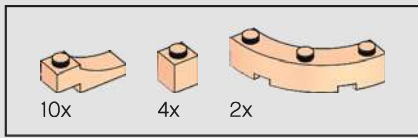

171

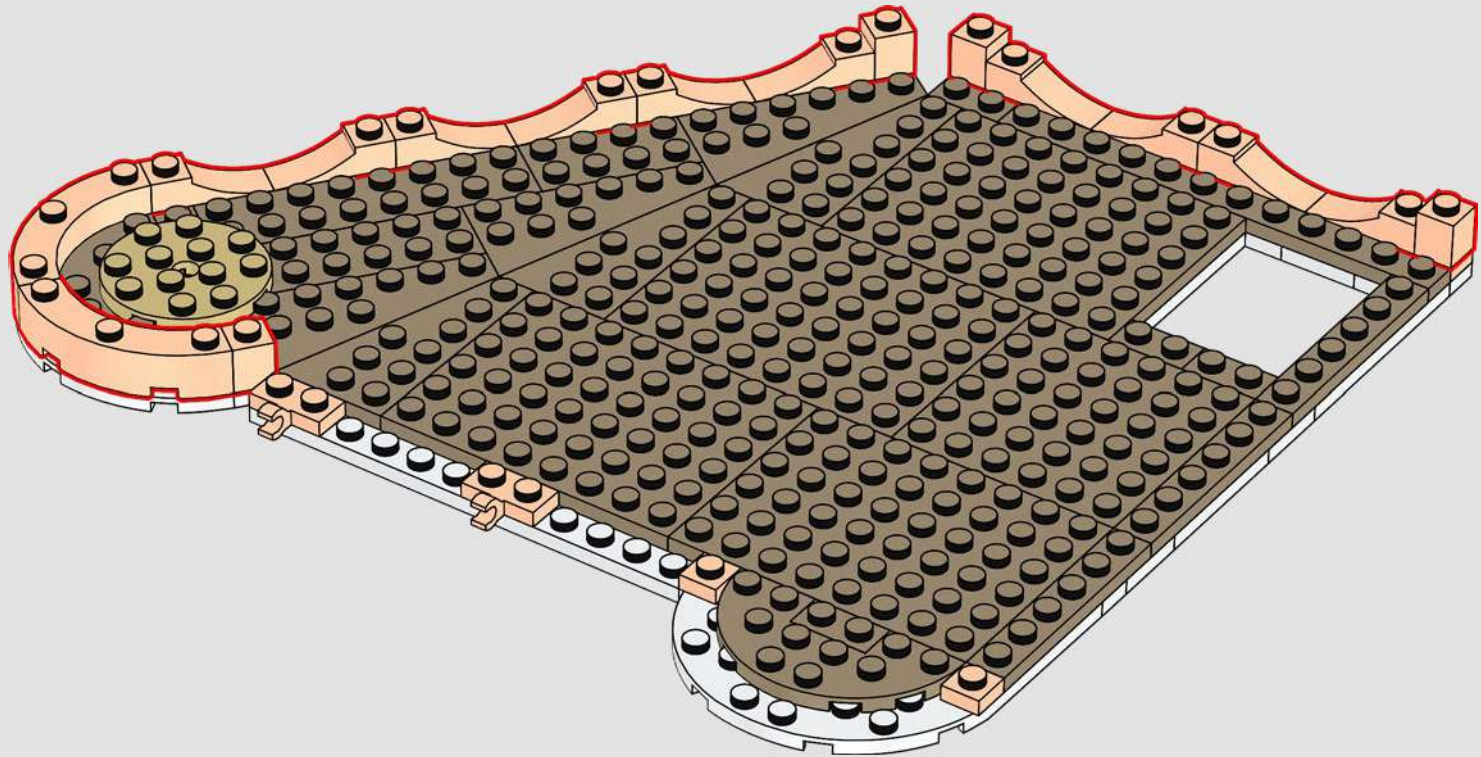

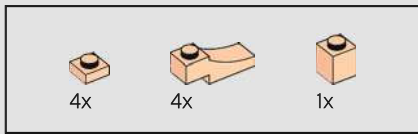

173

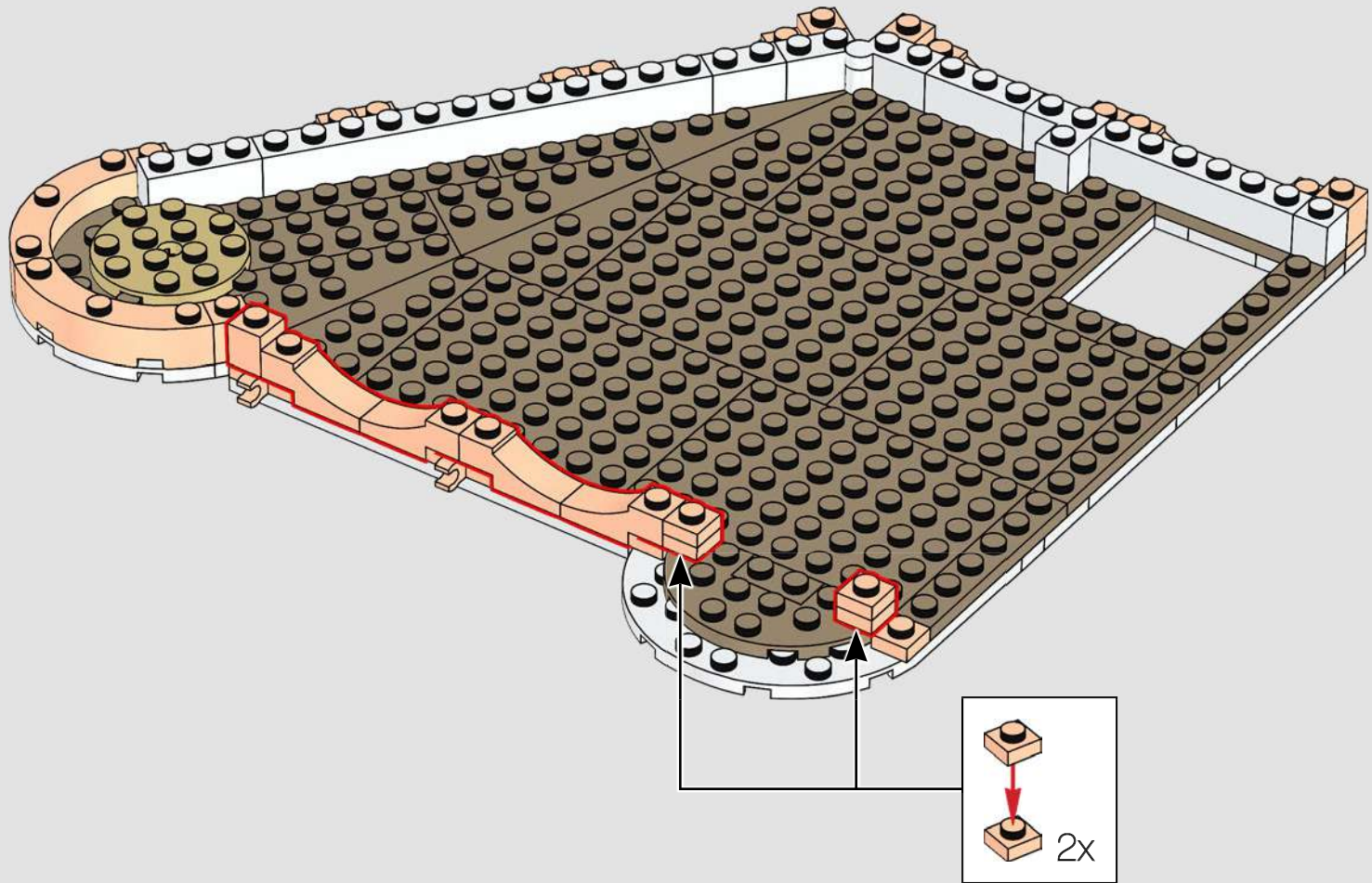

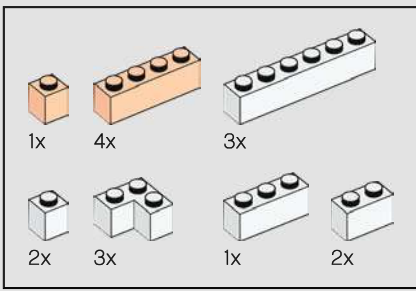

174

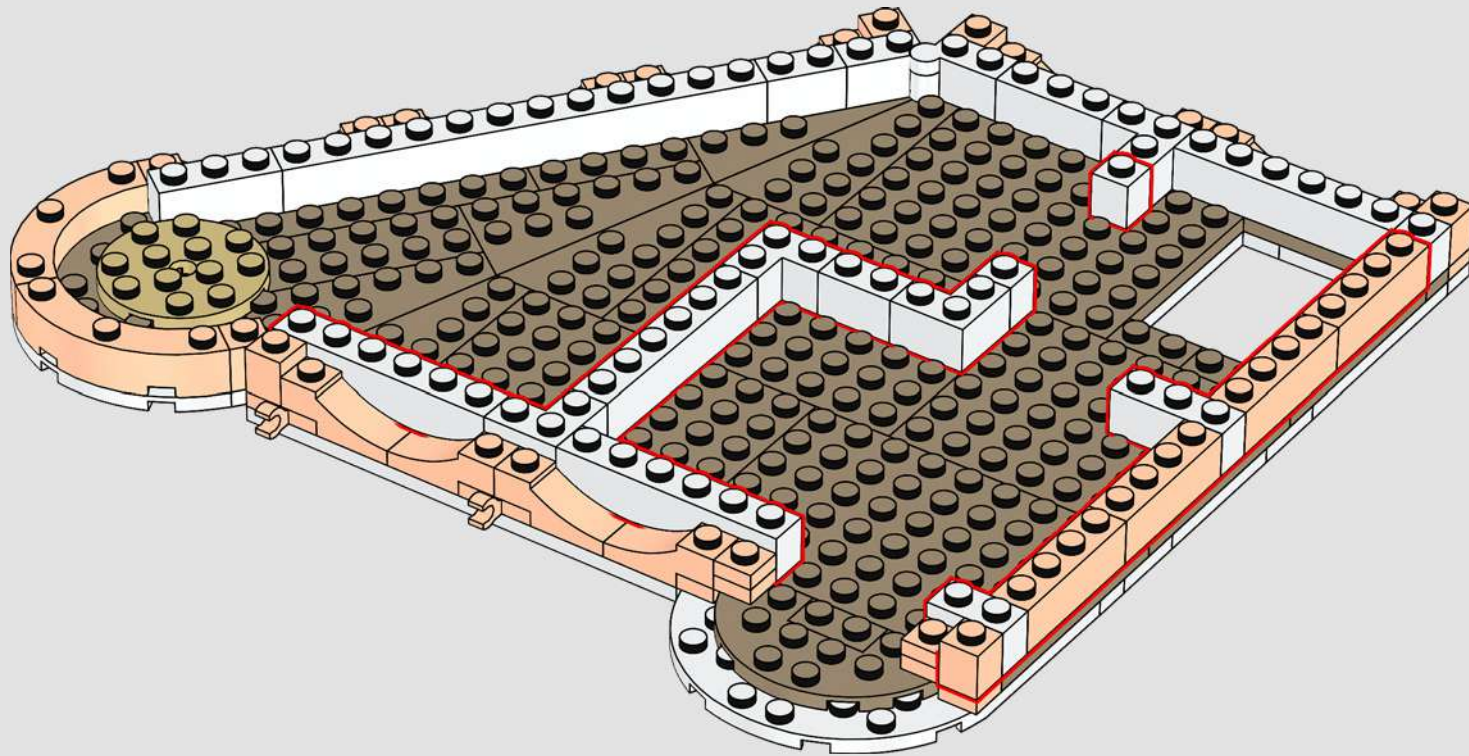

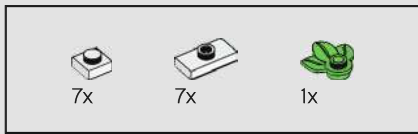

175

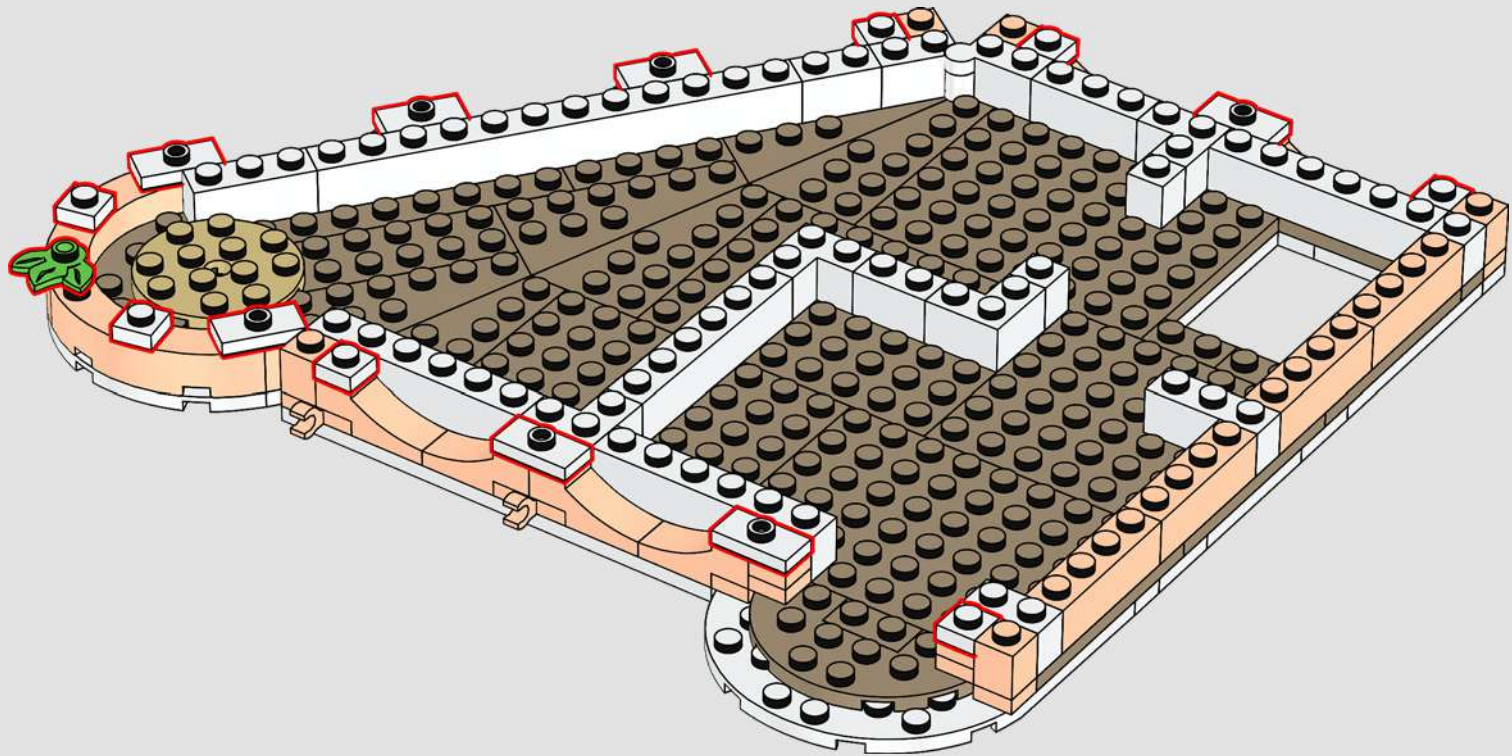

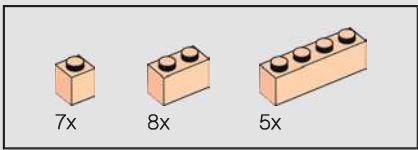

176

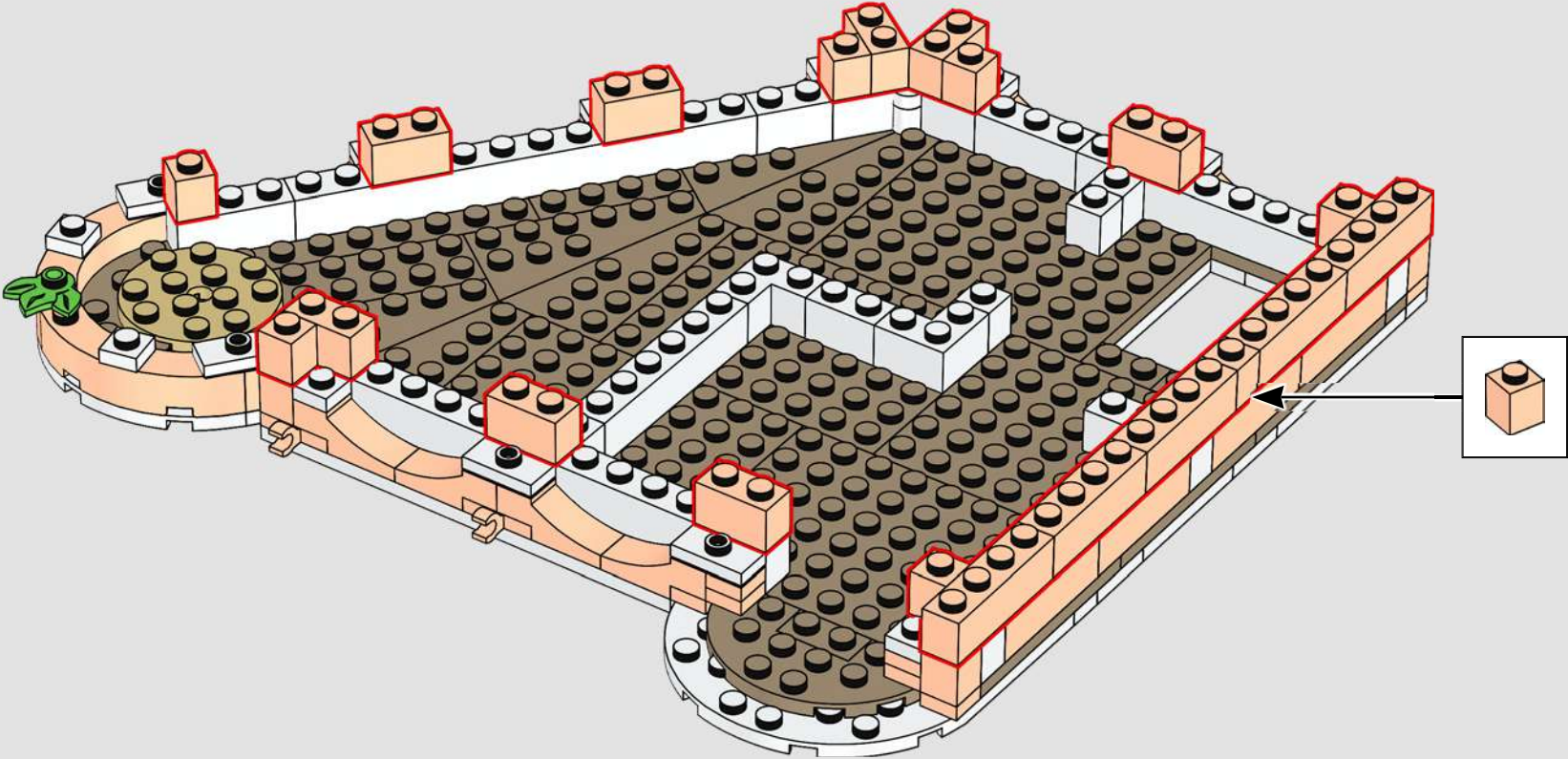

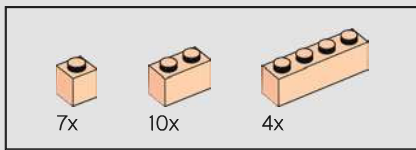

177

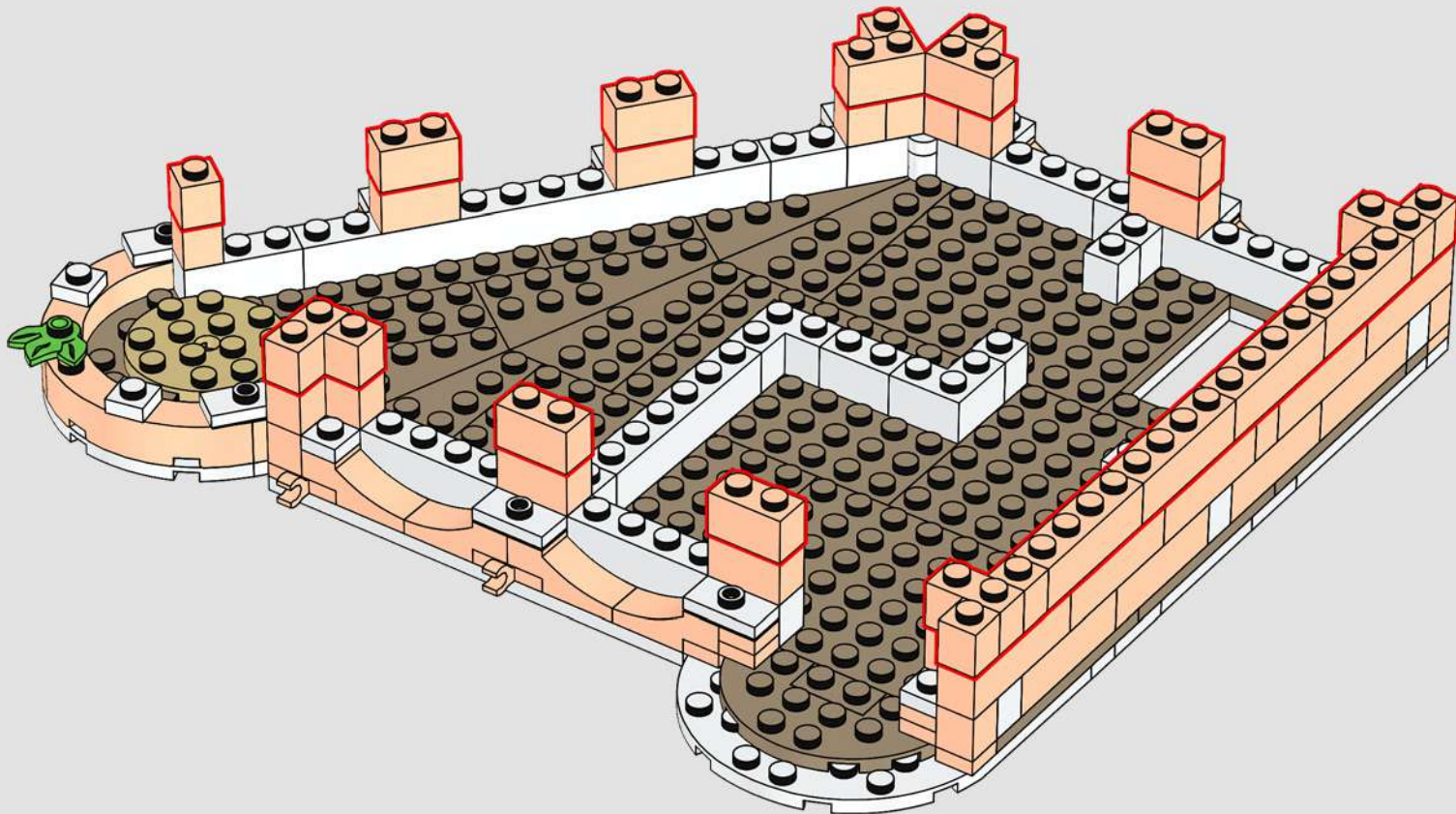

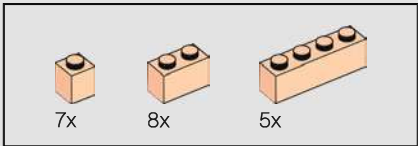
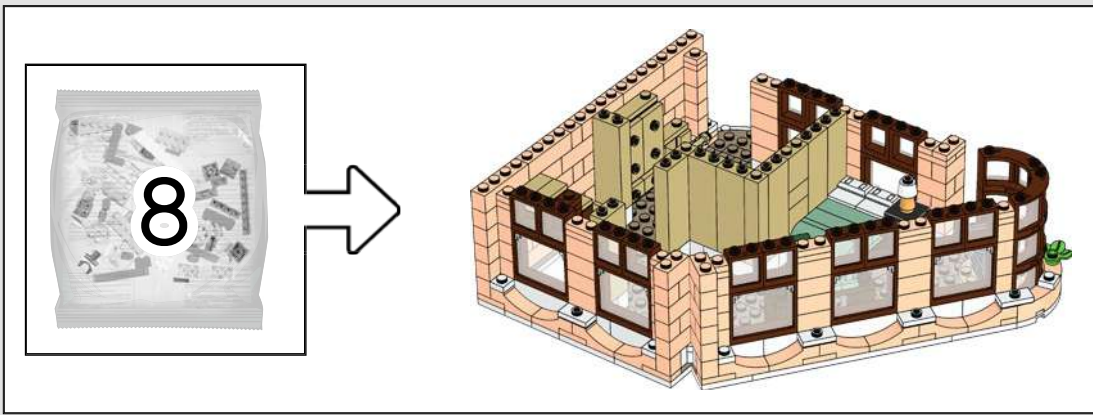

178

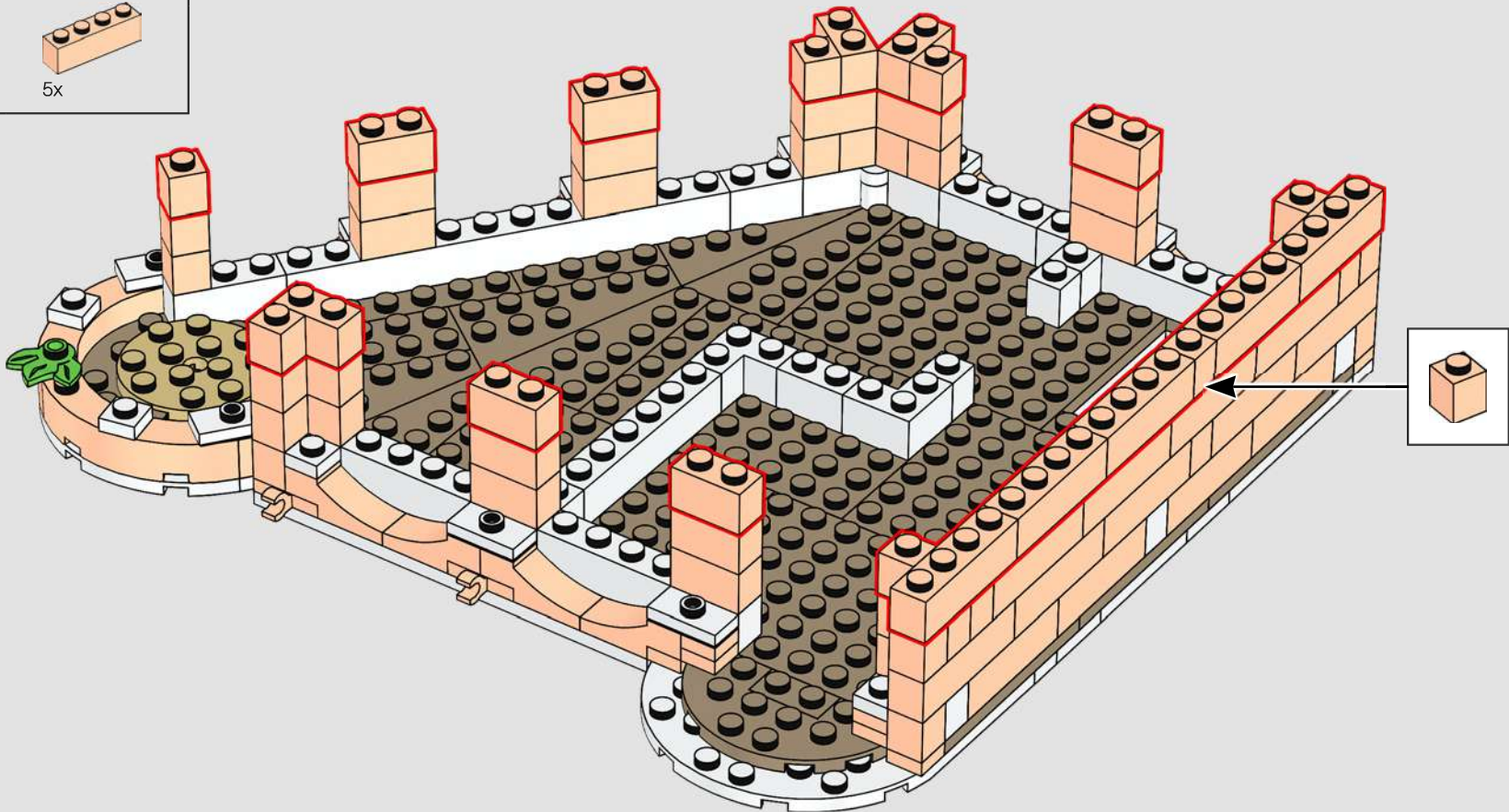

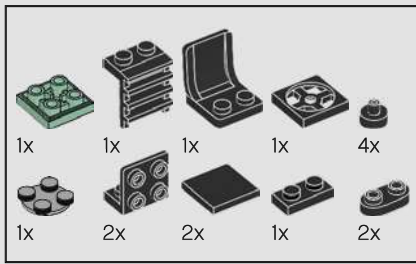

179

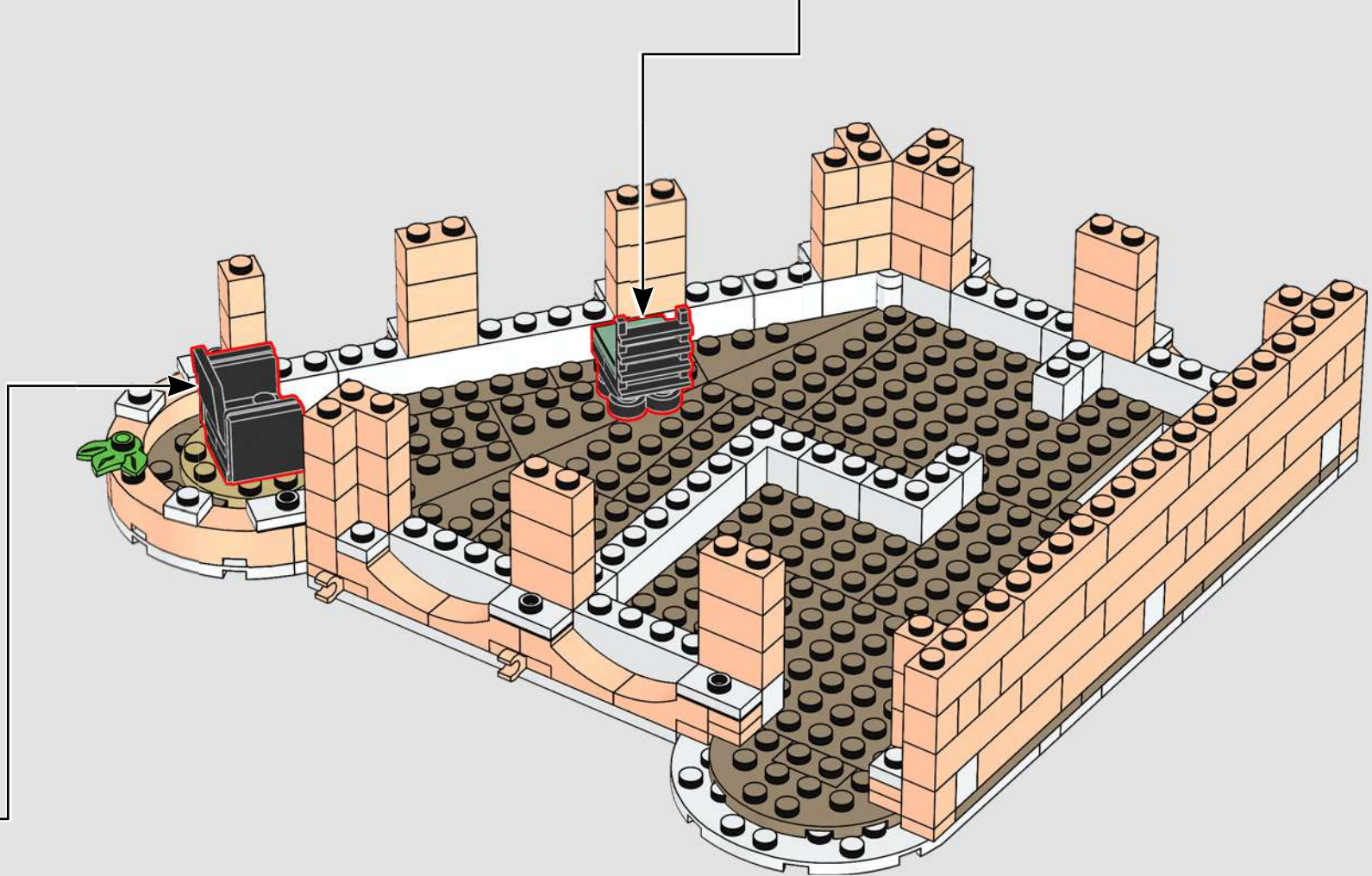
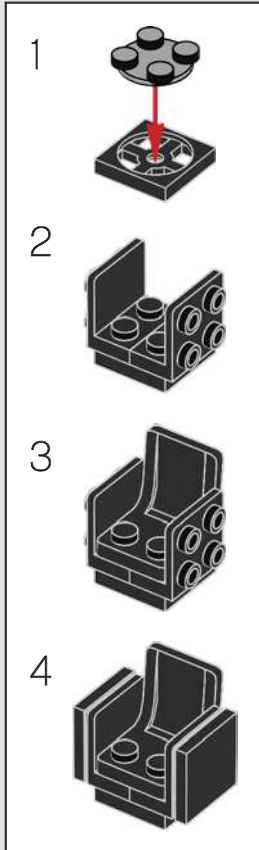
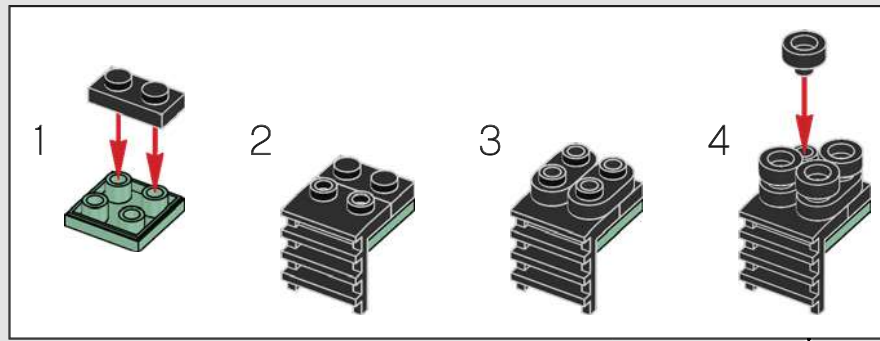

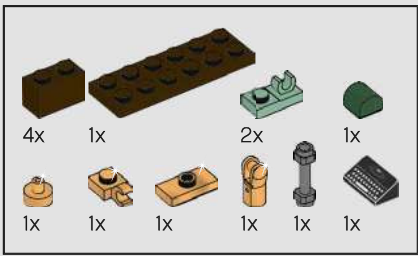

180

1



2

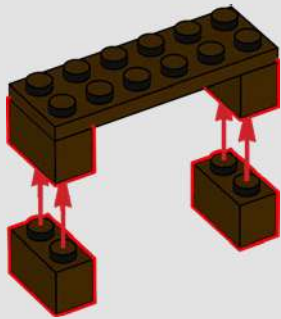

3

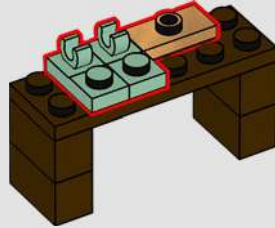

4

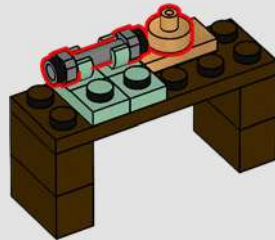

5

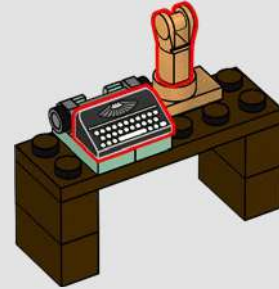

6

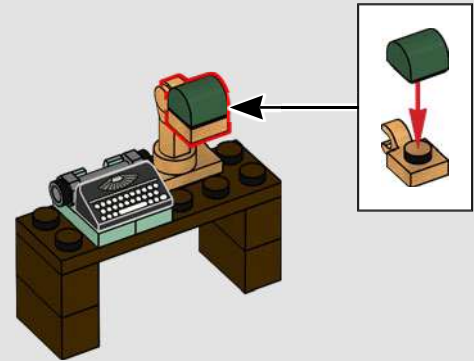

The local typewriter company has recently made sales to both the Hotel and to the 10278 Police Station set.

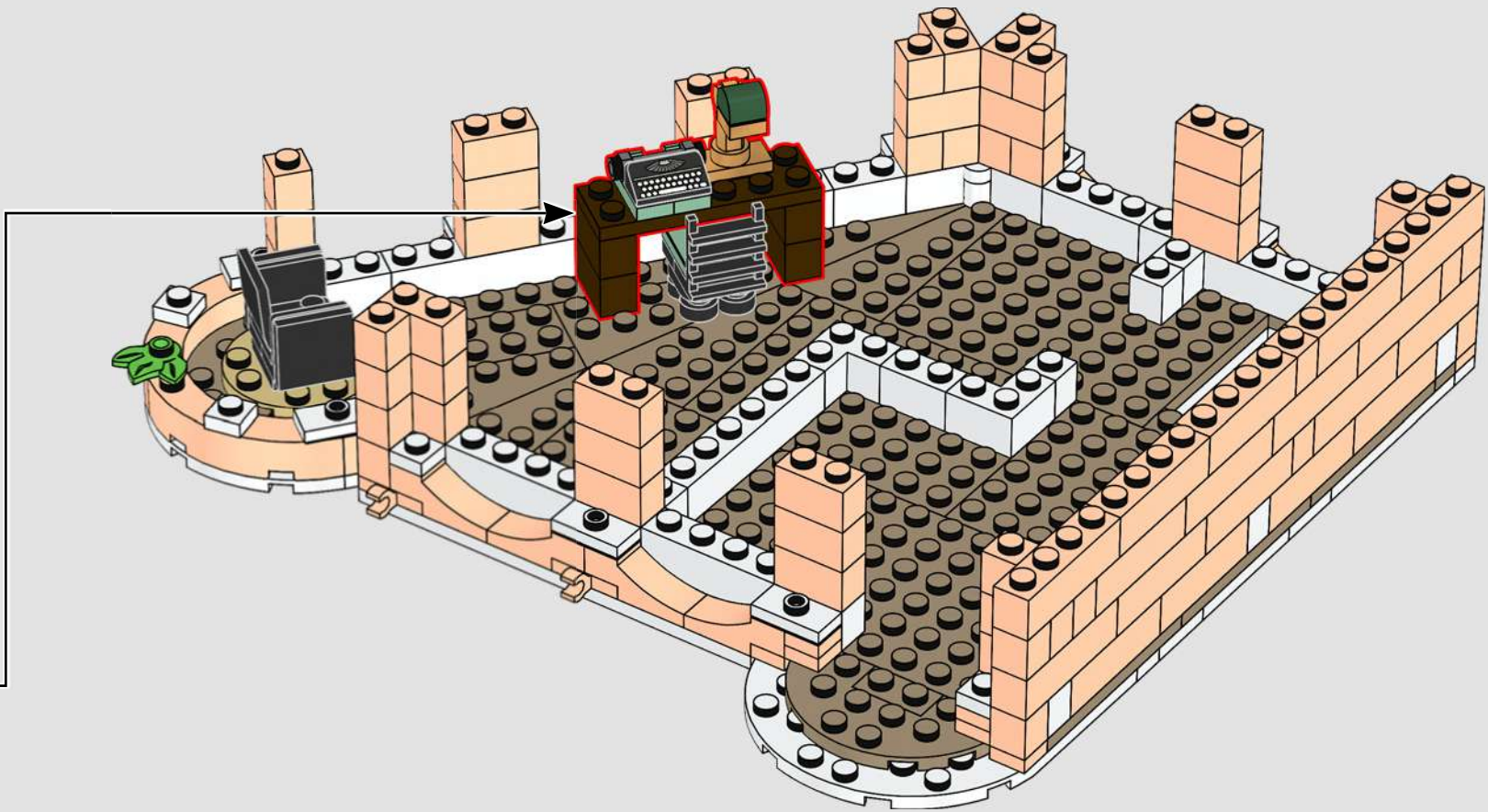

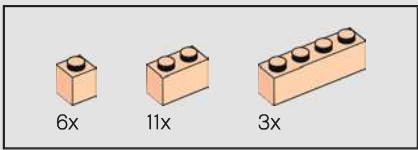

181

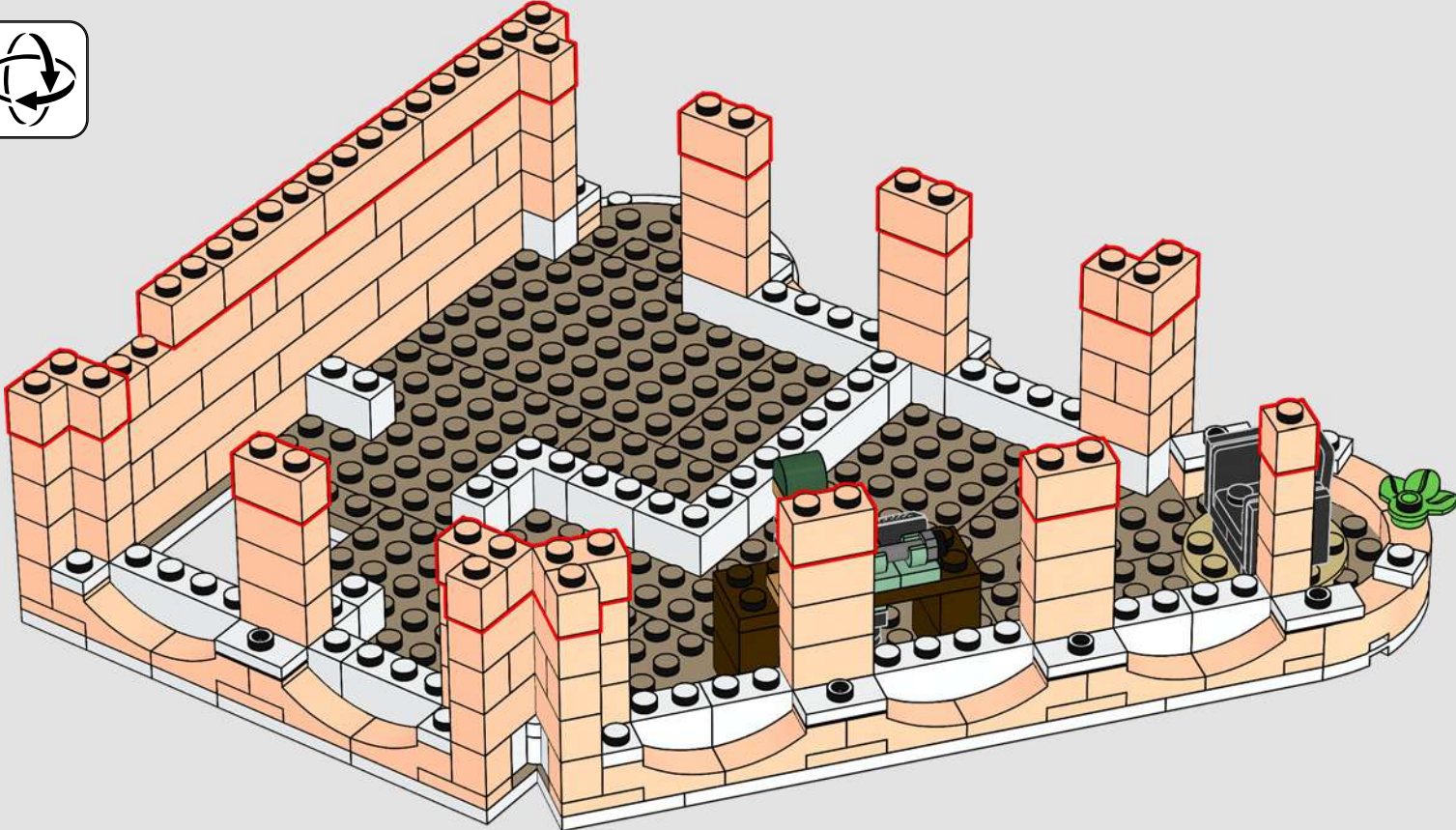

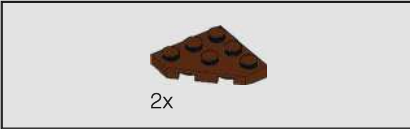
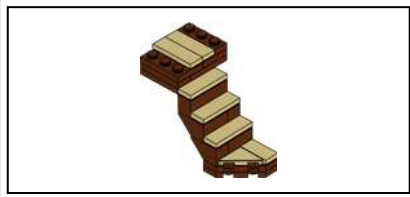

182

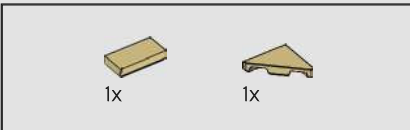
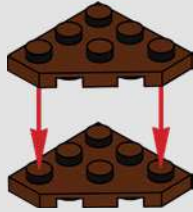

183

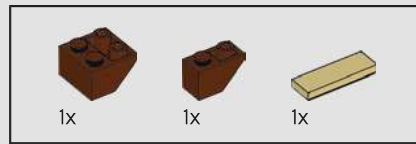

184

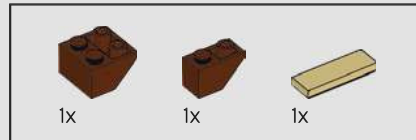
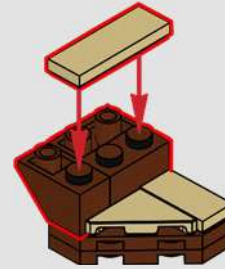

185

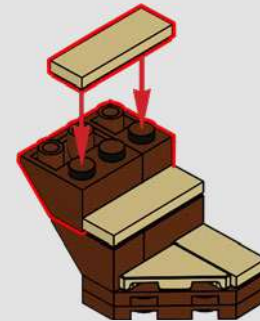

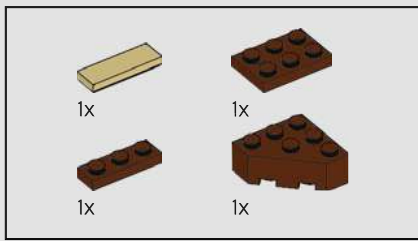

186

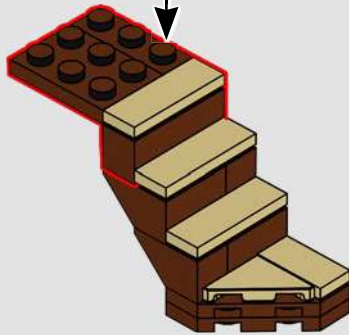
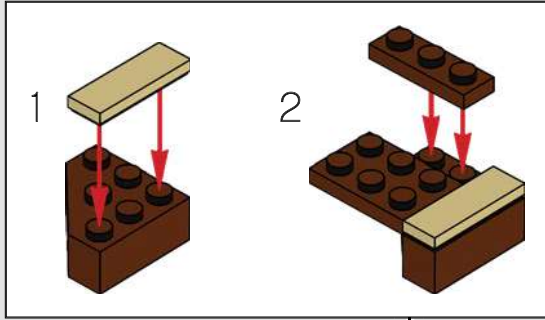

187

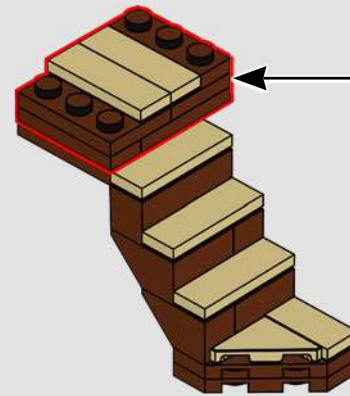
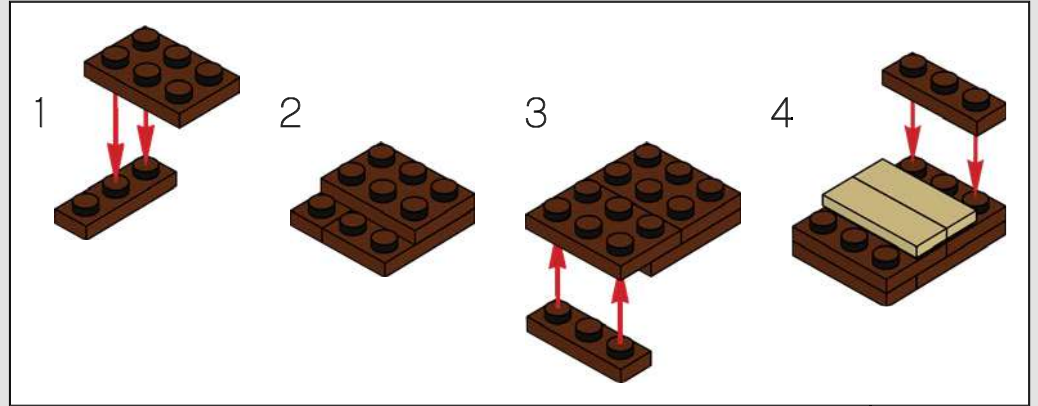



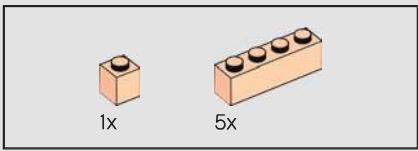

189

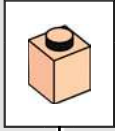

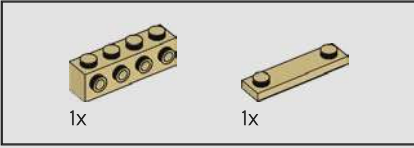
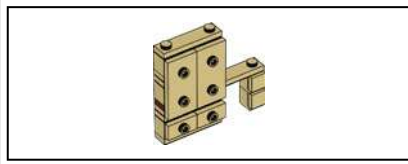

190

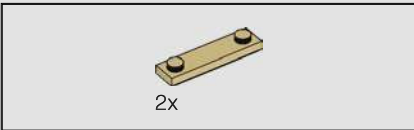
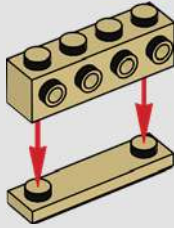

191

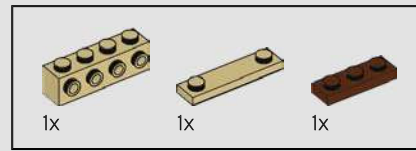
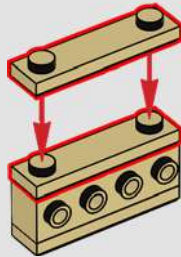

192

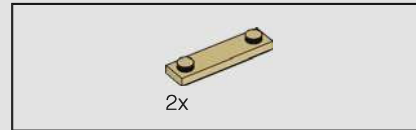
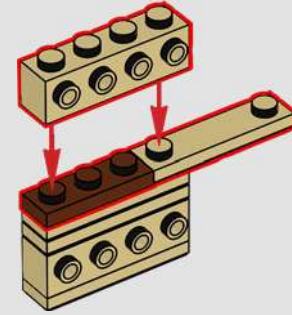

193

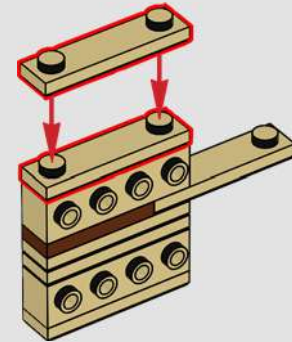

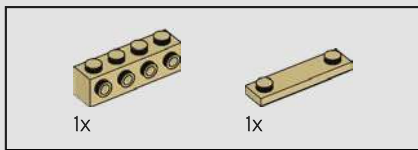

194

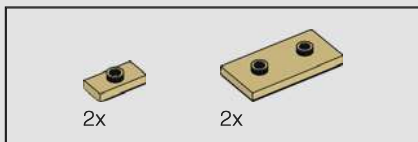
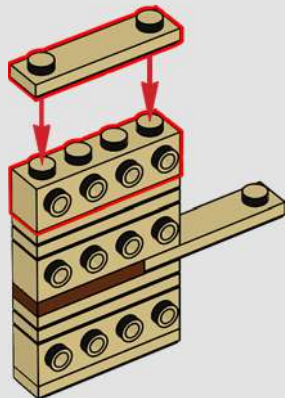

195

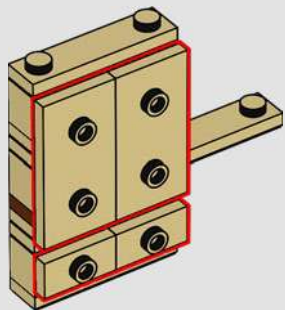

196

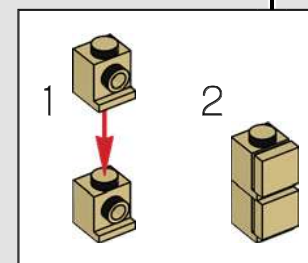
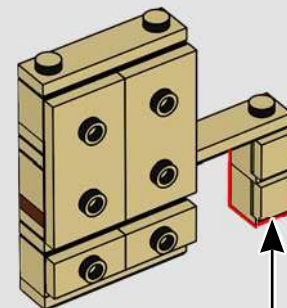

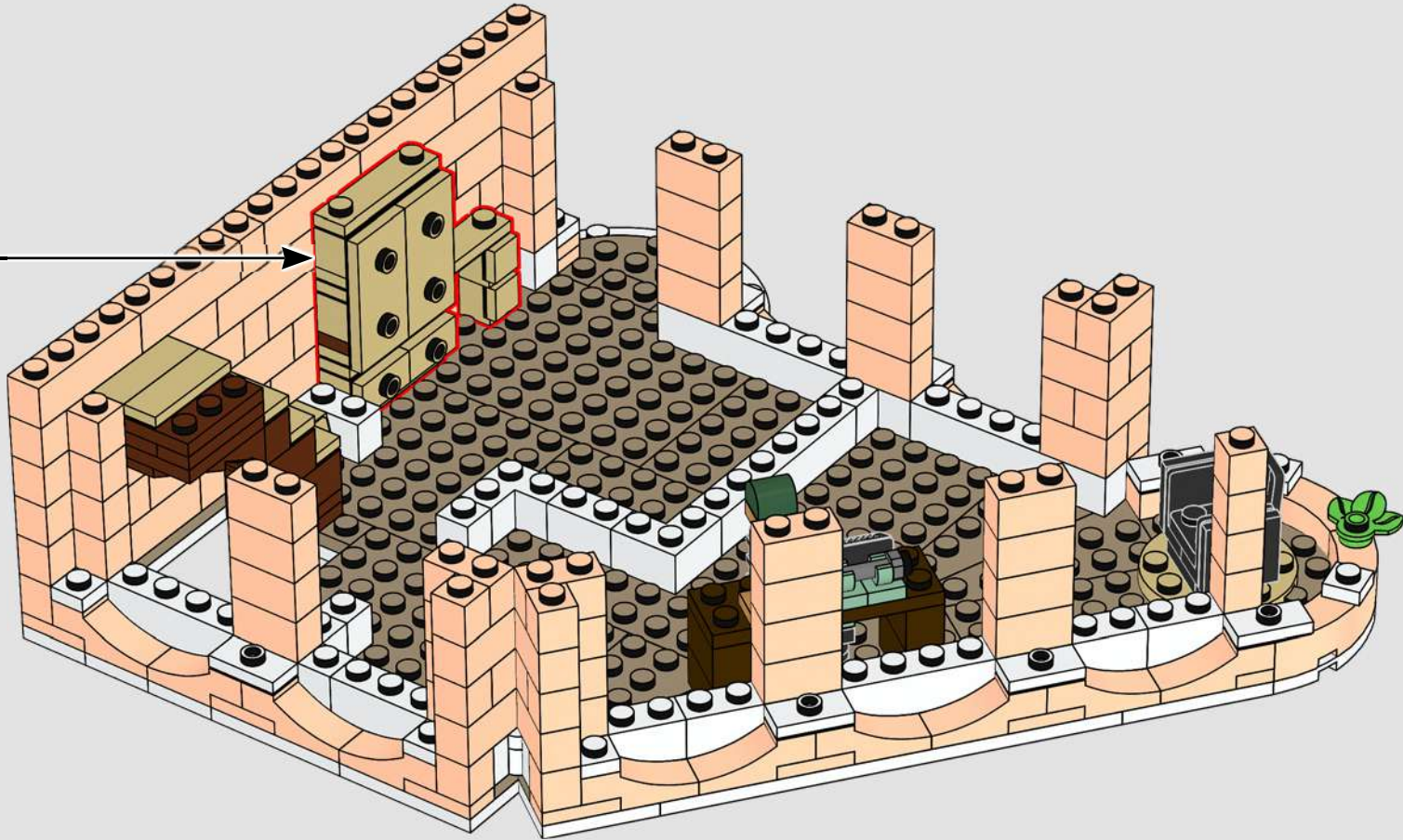

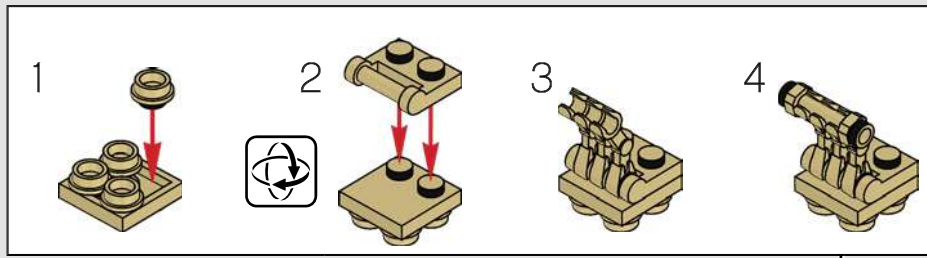
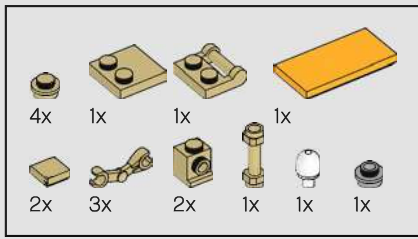

198

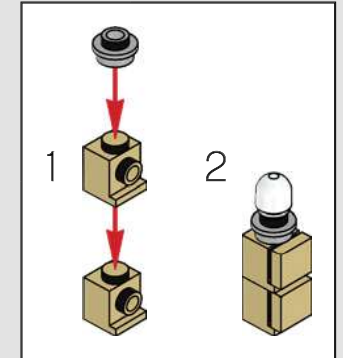
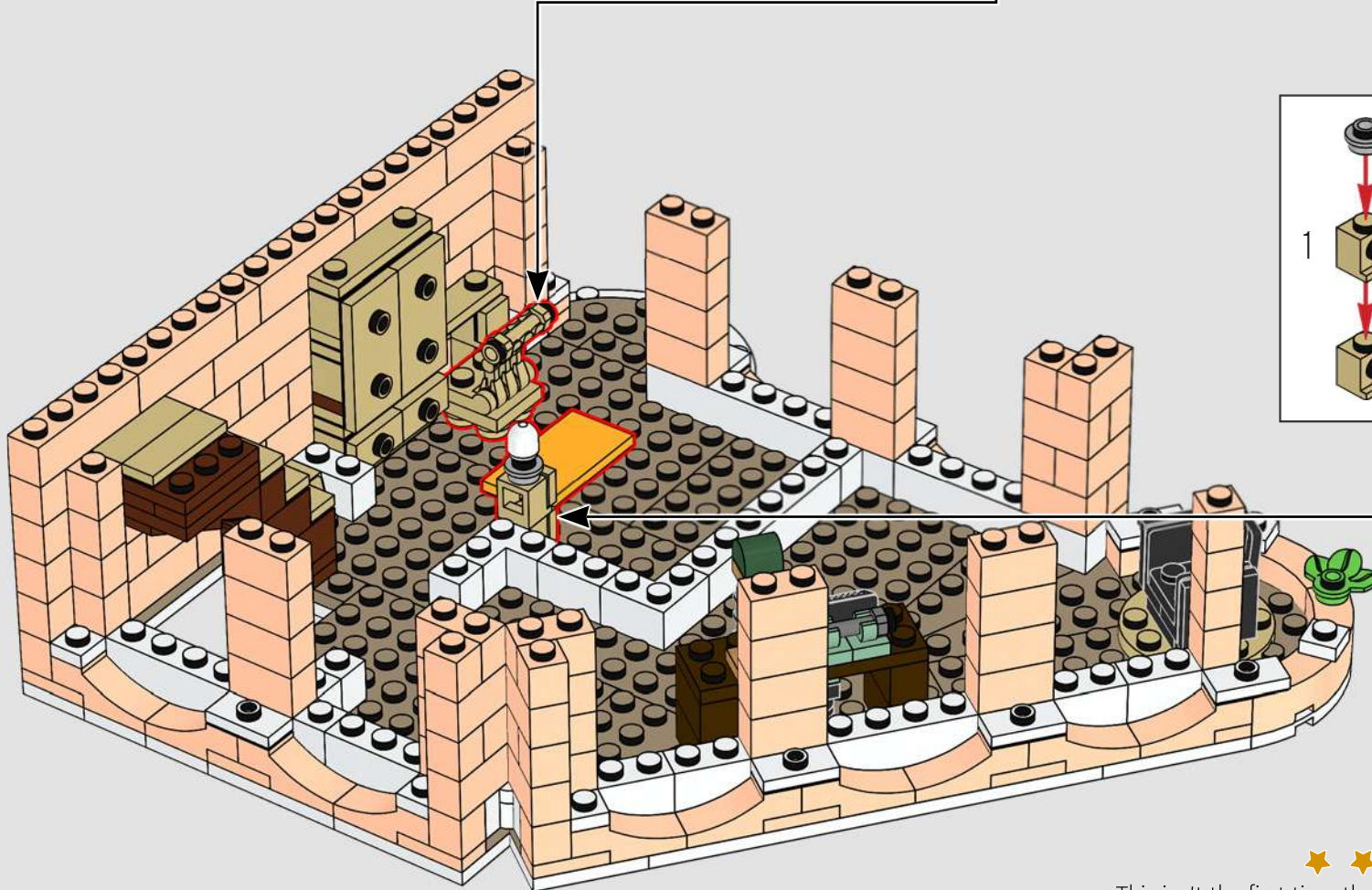

This isn't the first time these robot arms have been used in a modular model... you can also find them forming the railing of the balcony in the 10190 Market Street set.

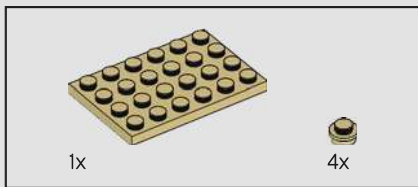

199

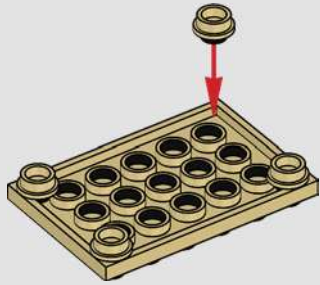

200

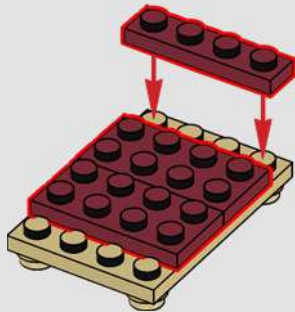

201

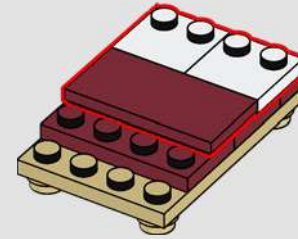

202

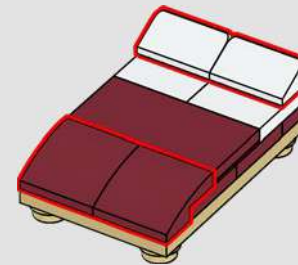

203

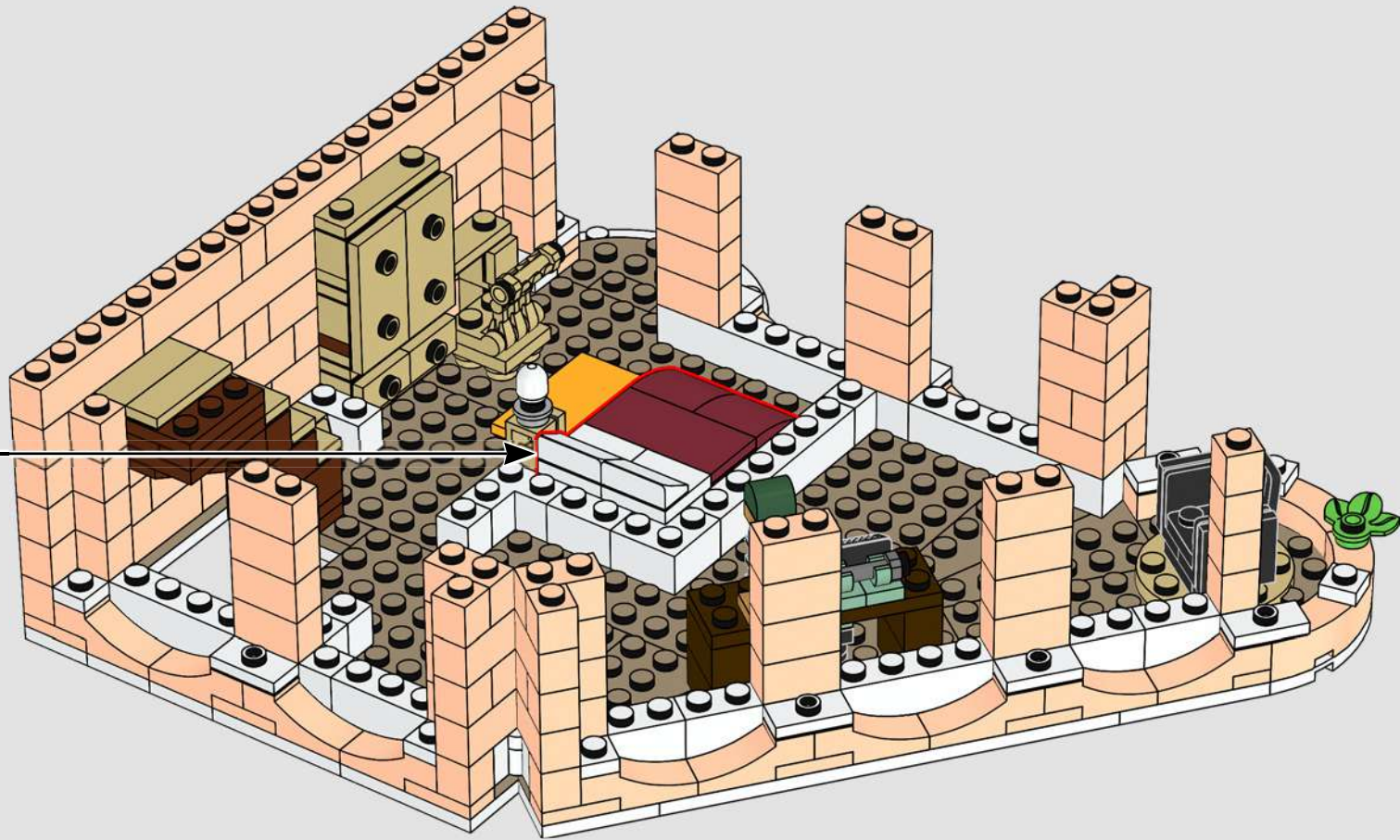

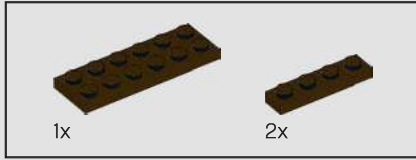
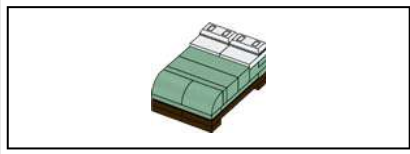

204

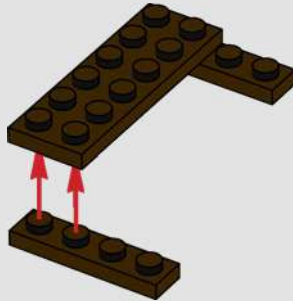

205

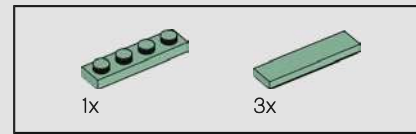
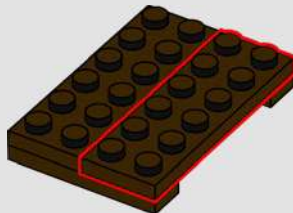

206

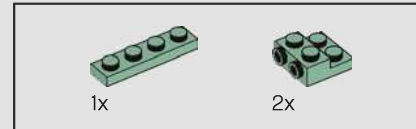
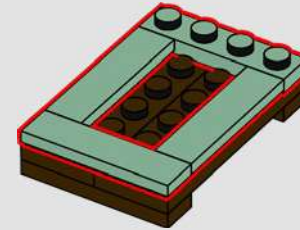

207

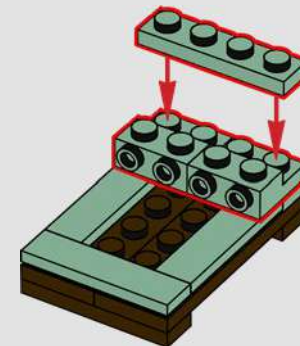

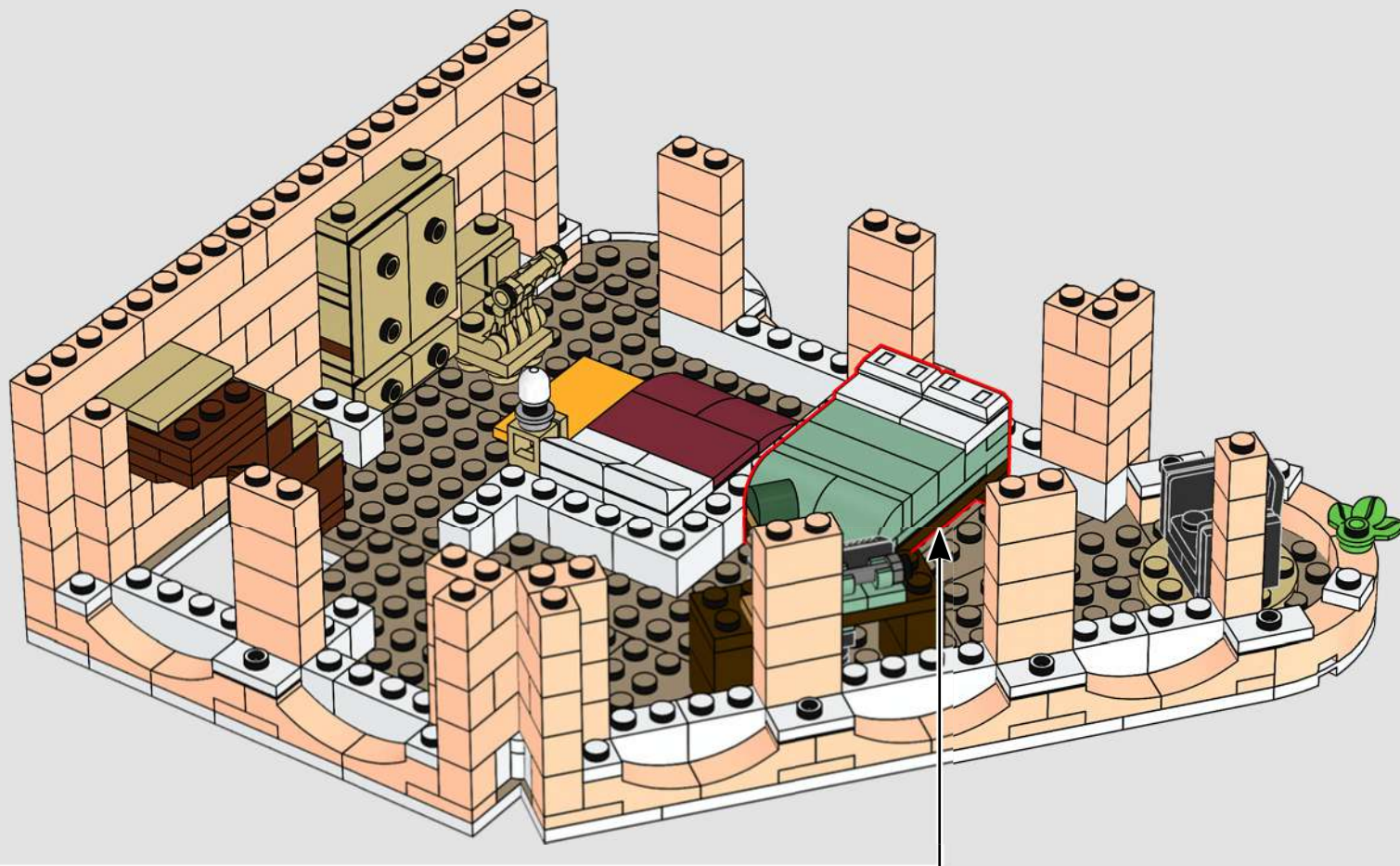

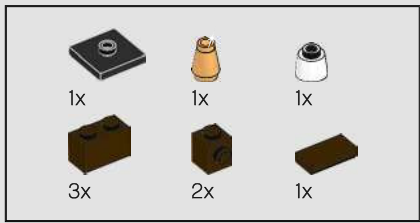

212

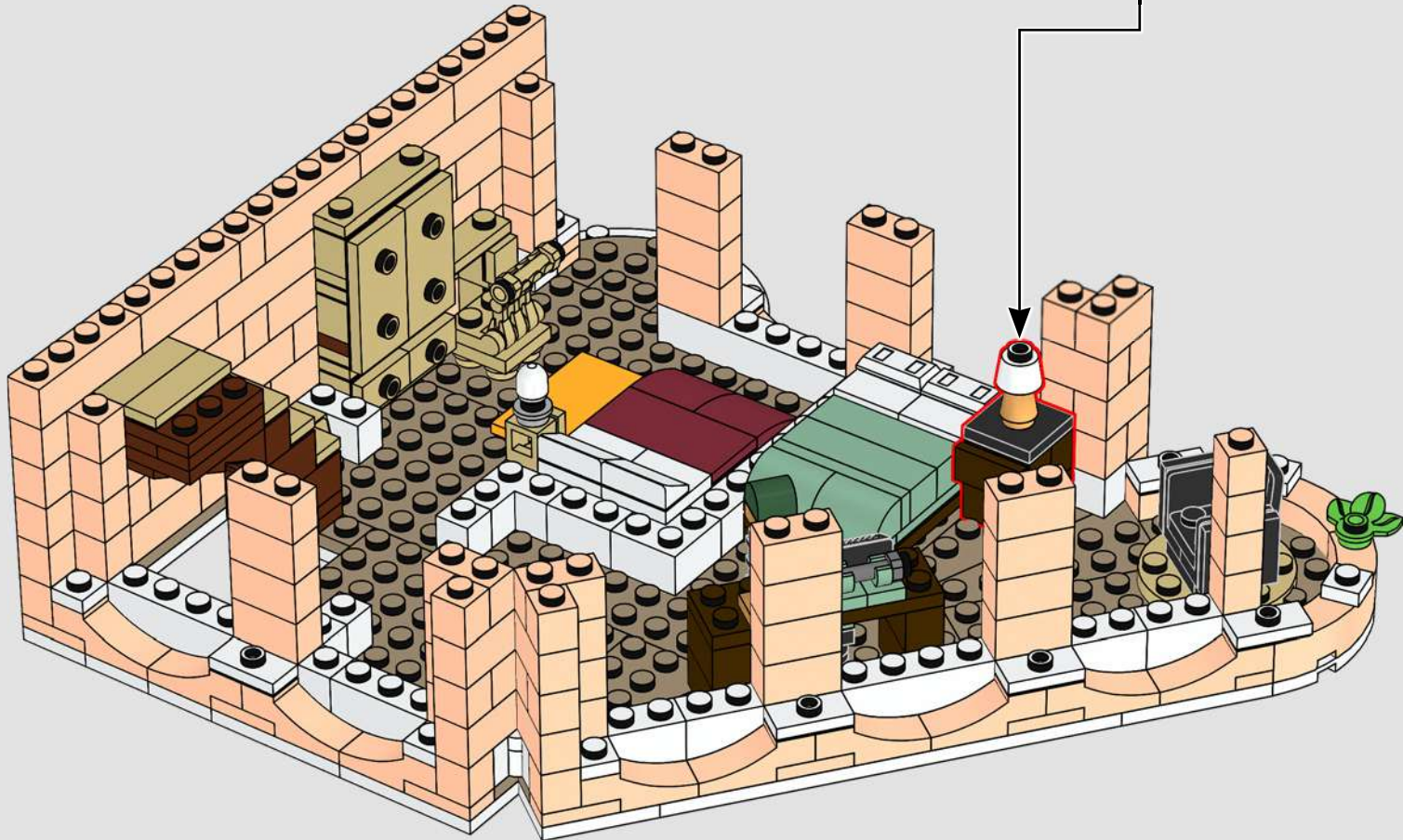
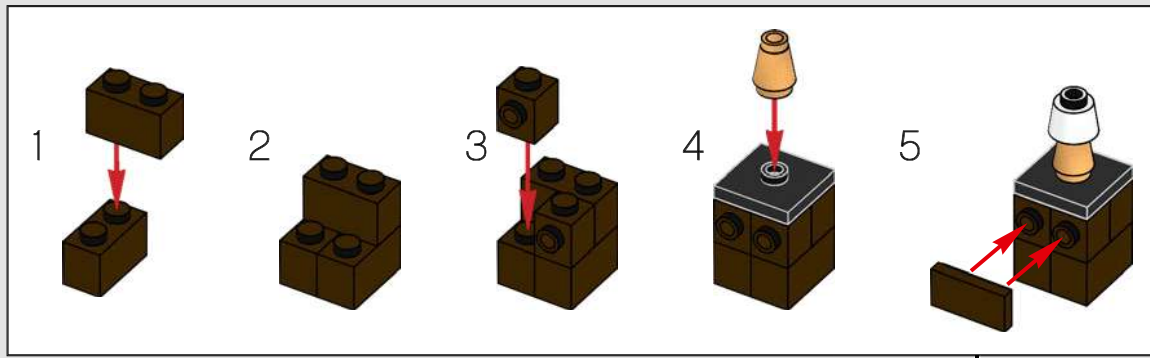

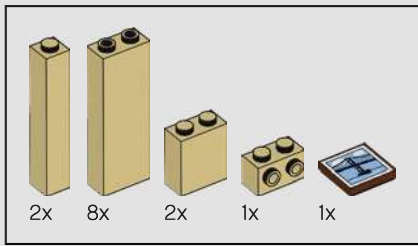

213

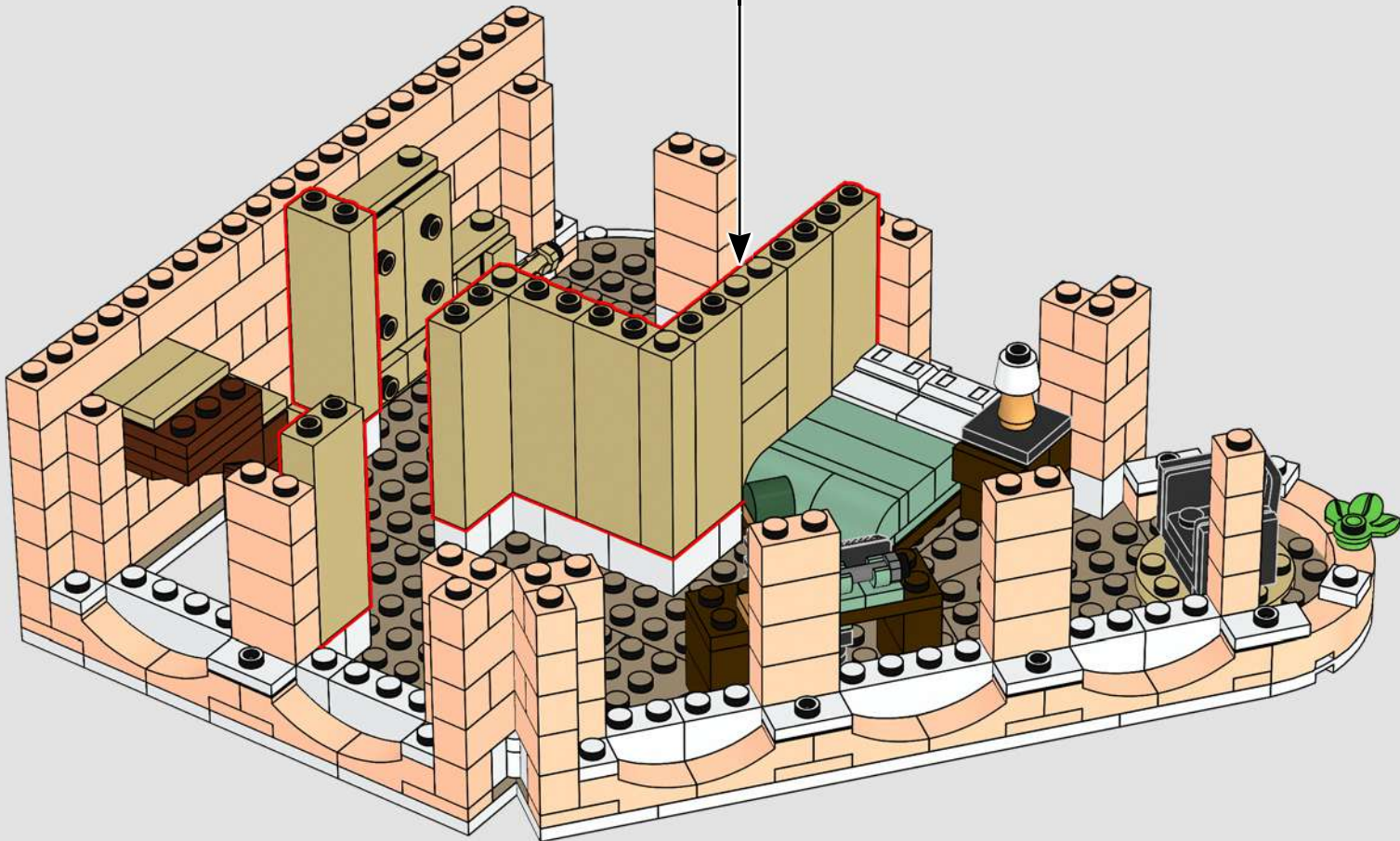
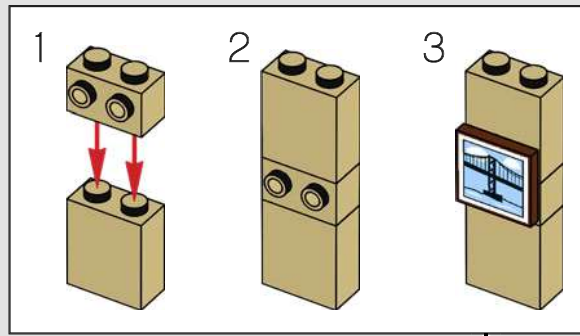

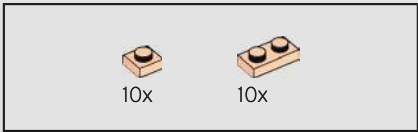

214

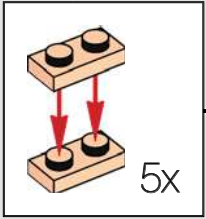
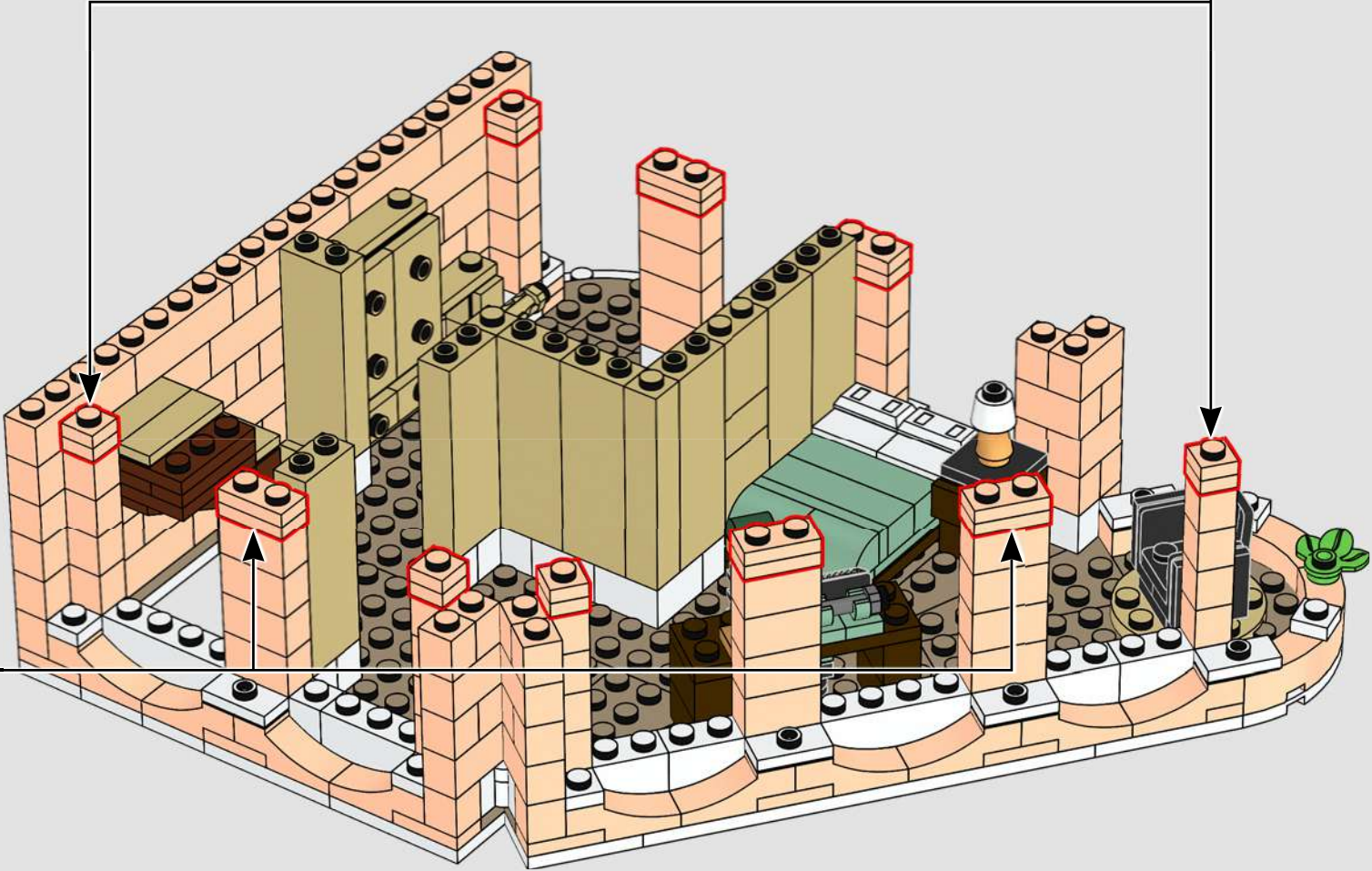
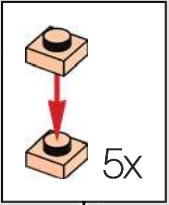



215

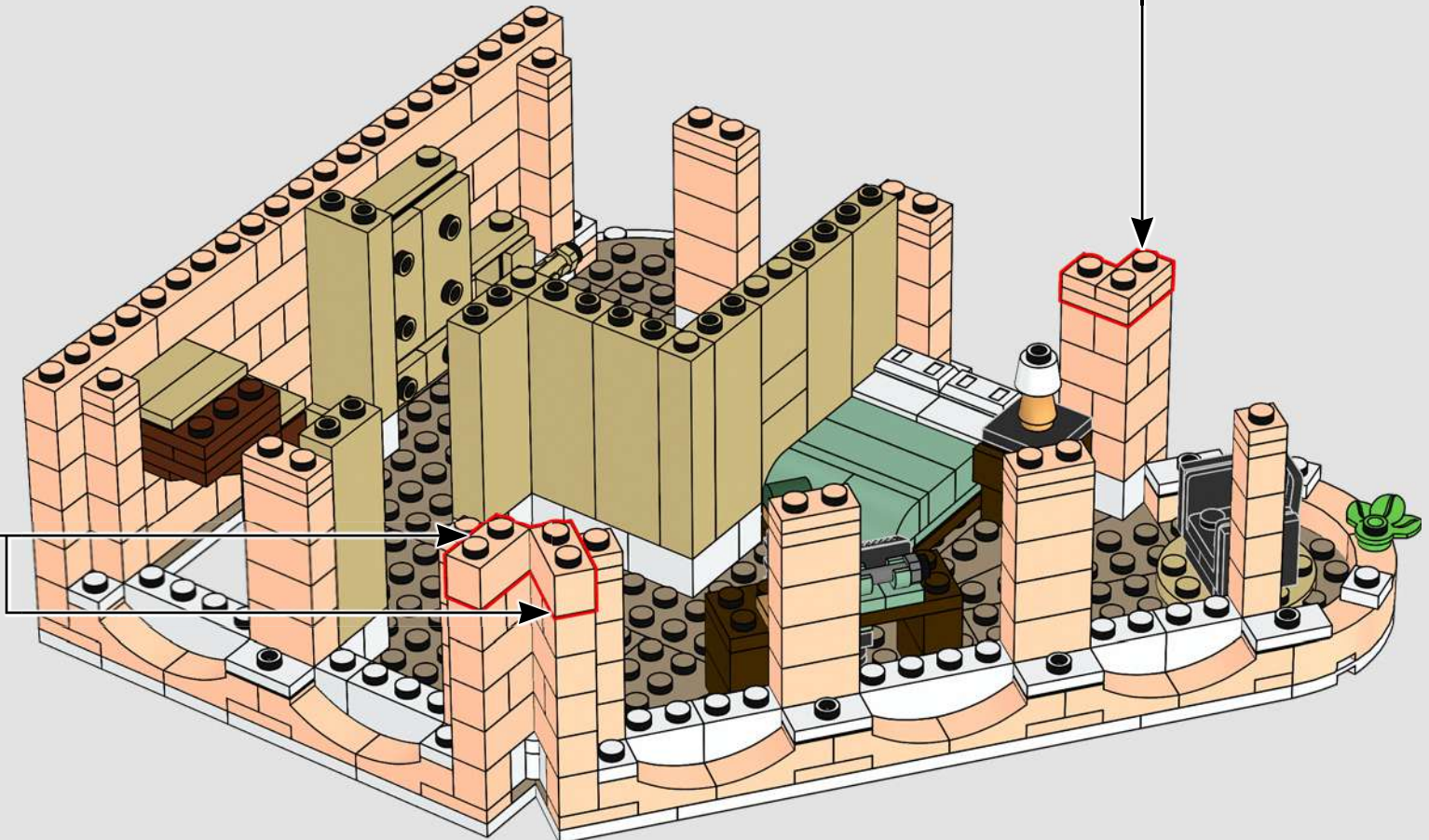
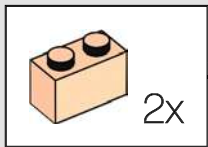
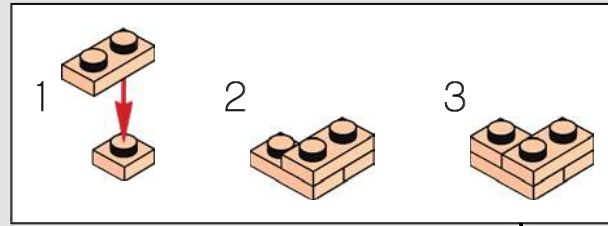

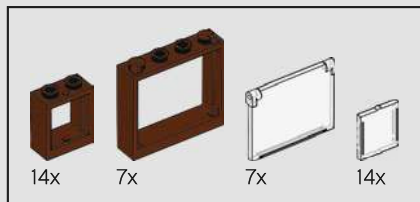

216

